



**Headquarter And Automation Factory:**  
Zhejiang Eternal Automation Sci-Tec Co.,Ltd  
Jiangkou Industry Zone, Ningbo, China  
E-mail: emcsales@emc-machinery.com

**Pneumatic Factory:**  
Ningbo Guanghua Pneumatic Industry Co., Ltd  
Xikou Industry Zone, Ningbo, China  
E-mail: pneumatic@emc-machinery.com

**Hydraulic Factory:**  
Ningbo Eternal Hydraulic Engineering Co.,Ltd  
Xikou Industry Zone, Ningbo, China  
E-mail: hydraulic@emc-machinery.com

Feel free to contact us for further information:  
**0086-574-28565766**  
**www.emc-machinery.com**

Good To Great. 追求更好



**GOOD TO  
GREAT**  
2014 · 追求更好



**Product  
Catalogues**  
产品型录



## E-MC devotes to be global leading automation solution platform

Focusing on industry automation technology R&D, product innovation and industry application. We are aimed at helping customers realize the goal of maximum production efficiency, offering high efficiency, intelligent, accurate and low consumption pneumatics and complete industry automation solution.

## CONTENTS >>

Now and Future	i001
Corporate Culture	i003
Honor&Certificates	i005
Leading and Developing	i006
Production Capacity	i007
Production Team	i009
Process and Control	i011
Technology And R & D Team	i013
Technical Support Team	i017
Sales Support Team	i019
Global Marketing Network	i021

<b>Pioneer Product</b>	i023
------------------------	------

<b>Innovative Product</b>	i028
---------------------------	------

<b>Core Product</b>	P001
■ Pneumatic Cylinder	P004
■ Electric Cylinder and Intensive Industry Robots	P039
■ Energy Saving Module	P045
■ Directional Valve	P055
■ Valve Island	P067
■ Solenoid Valve	P071
■ Air Filter, Regulator and Lubricator	P123
■ Fittings	P135

• This catalogue is divided in different color block for different product ranges for better guiding.

## Now and Future

E-MC focuses on industry automation technology R&D, product innovation and industry application. We are aimed at helping customers realize the goal of maximum production efficiency, offering high efficiency, intelligent, accurate and low consumption pneumatics and complete industry automation solution.

Since founded in 1986, E-MC experienced over 20 years continuous innovation, exceeding and self-breakthrough, and becomes to be a national new high-tech enterprise with R&D, manufacturing, and brand operation.

In 2009, with strong background of Fluid Power & Electromechanical System in Zhejiang university, E-MC set up China national class pneumatics and industrial automation R&D center, which gives an absolute leading competitive edge in fields of technology R&D, production innovation, process reengineering, system application and complete automation solution.

Today, E-MC enjoys:

- Over 100,000 m2 three factories;
- 100+ World class facilities;
- 40+ R&D engineers led by doctors and professors;
- 50+ Patent rights ;
- 60+ Sales engineer;
- 600+ Staff;
- .....

Today, all E-MC Customers conveniently enjoy:

E-MC high quality products and golden service through our wide market channel and service network in Europe, in big America area, in the Middle East...about 117 countries and 82 cities all over the world.

In the future, E-MC will continue follow the core concept “innovation create value” , go through the new stages for product innovation, process innovation and service innovation. We will create more value for customers, lift efficiency for society production, lead automation technology to systematic, flexible, integrated, and intelligent future with every effort.

Devoting to be global leading automation solution platform, E-MC will keep moving and never stop!





# CORPORATE CULTURE

## CONCENTRATION

Concentrated on industry research and accumulation.  
Concentrated on product improvement and innovation.  
Concentrated on system optimization and upgrading.

## INNOVATION

Purse technology prospect and guiding.  
Purse product performance and standard.  
Purse process accuracy and reliability.  
Purse management controlled and high efficiency.  
Purse service thoughtful and valuable.

## RESPONSIBILITY

Shoulder corporate objective and mission.  
Shoulder customer trust and growth.  
Shoulder industry revitalization and development.

## GRATITUDE

Thankful for dedicated team spirit and devotion.  
Thankful for customers choice and recognition.  
Thankful for partners support and follow.  
Thankful for opponent' s inspiration and motivation.  
Thankful for community tolerance and give.

## Honor and Certificates

- China National High-tech Enterprise
- Enterprise Technology Creation Team
- Zhejiang University talent training base
- Famous Brand of Zhejiang Province
- Top 10 Enterprise Comprehensive Capability Ranking of Ningbo city
- Appointed China Enterprise of thousand Sino-USA enterprise cooperative plan
- Zhejiang Export Brand
- The Mayor Quality Award
- Famous Product of Zhejiang Province
- Product Certificate of Beide UK
- TUV Certificate
- Public Service Platform
- State High-tech enterprise R&D Center
- Professor Studio

## Leading and Developing

As the fastest growing local company of automation industry, with more than 20 years efforts and hard work, E-MC has accumulated rich experiences working with global Top 500 companies, and successfully constructed the most broad sales network in China fluid power field, including 117 countries overseas marketing service network and domestic 80 cities deep marketing channels. Meanwhile, E-MC is the only fluid power company joint venture with Zhejiang University, which gives E-MC very powerful technology background for E-MC R&D Center and Laboratory.

The past achievements laid the status of E-MC today as the biggest export manufacturer in China, we' re sure, the continuous innovation and changes will lead E-MC moving towards to a new high stage!

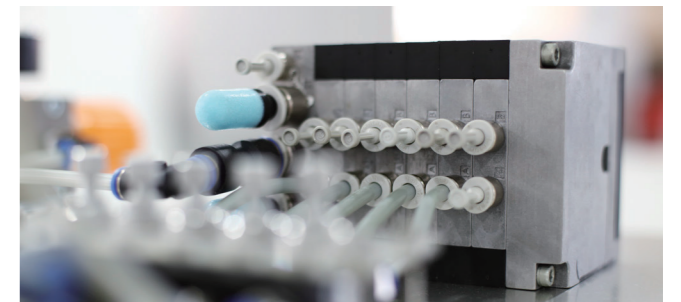
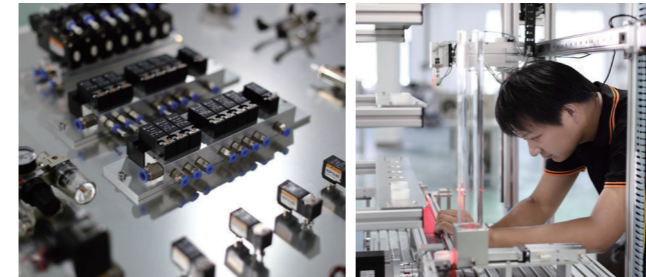

# PRODUCTION CAPACITY

## MAZAK Horizontal Machining Center



### Manufacturing and Facilities

With powerful support of technical design, strong base of process technics, we' ll deep carry out and flow down All-Staff-In quality mind, to manufacture perfect product with E·MC honor. Take product application as direction for designing and developing, motivated by customer satisfaction, with new facilities, with new technics, already become E·MC product brand positioning foundation.

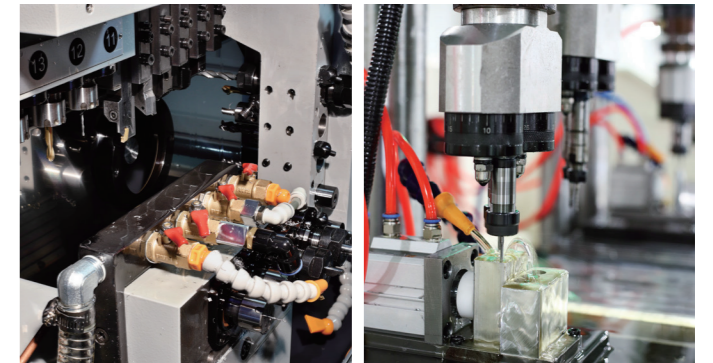

**PRODUCTION  
TEAM**





## Process and Control

E·MC founded complete process management system, driven by customers demand, aiming at high efficiency manufacturing results from lean production, with innovation management practices in the divided area of planning, technics, spot, material, facilities and quality checking.



## Technology and R&D

- National fluid Power and Electromechanical system R&D Center
- Strong R&D Team with over 40 engineers, doctors and professors
- Over 20 years' product design experience in pneumatic and fluid control field
- Realization capability of pneumatic system and complete industry automation solution
- Strong support of a complete and leading facilitated laboratory
- High efficiency system for personalized products
- Products R&D in predicted and applied industries
- 3 invention patent rights; over 50 applied new design patent rights
- Deep design joining in various industry application system

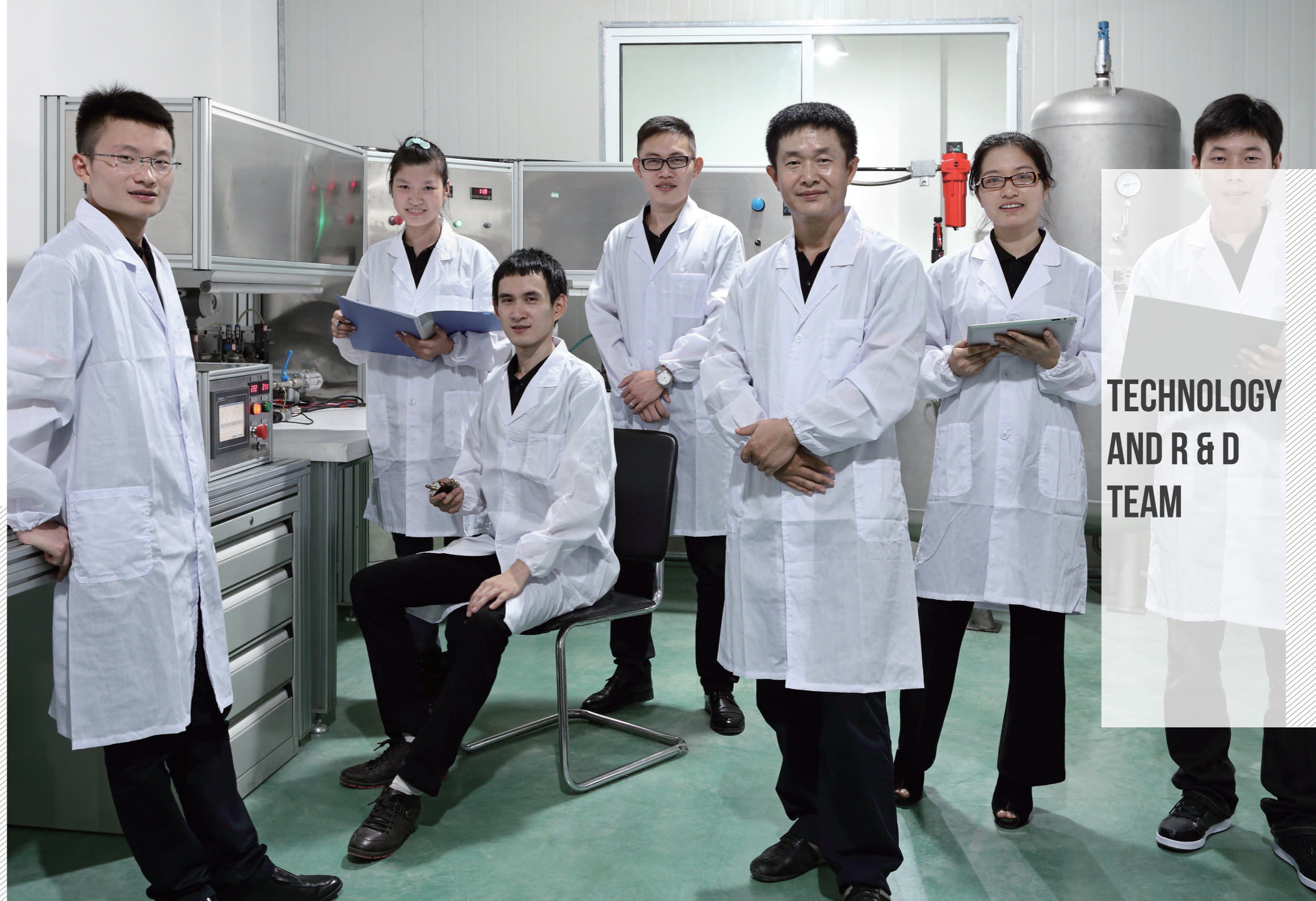

**TECHNOLOGY  
AND R & D  
TEAM**



## R&D Capability

E-MC sticks to the core value of “innovation creates value” as always. The E-MC pneumatic components technology study changes from mechanical machining mainly to more intensive, compact, electromechanical integration of mechanics & electric fields. The world class experiment installation and testing facilities give strong R&D platform for E-MC continual creation and development.



## Technology Capability

The main function of E-MC technical center is to realize personalized product in high efficiency and develop more applied products. E-MC invites a lot of top technology talents joining, who have original ideas on products and technics, mind of continually sticking to innovation and never stop looking for further improvement of every product. The E-MC technical team continuously gives technology upgradation and renovation, just to make all products fits more for production, fits better for system, and achieve higher safety and stability performance.

# TECHNICAL SUPPORT TEAM



## Consultative Minute-by-minute Technology Support

E-MC offers all-rounded technology support service, solves problems effectively, helps customers to lift operation efficiency, saves time and lowers down product damage expense.

- Better system design
- Application solution
- Operation & maintenance instruction
- Troubleshooting hotline



**SALES  
SUPPORT  
TEAM**

## Entire Users Service

E-MC focuses on study on users experience in various aspects and levels for better meeting customers' existing and potential demands, and offers high value added butler service.

- Solution support
- Demand management support
- Technology consult support
- Delivery support

## Entire Business Development Service

E-MC offers personalized tactics support for worldwide distributors, entirely help them to further develop business, grow faster and build core competitive advantage.

- Regional market expansion tactics support
- Important customers development solution and technology support
- Business and technology training support
- Regional market order maintenance support

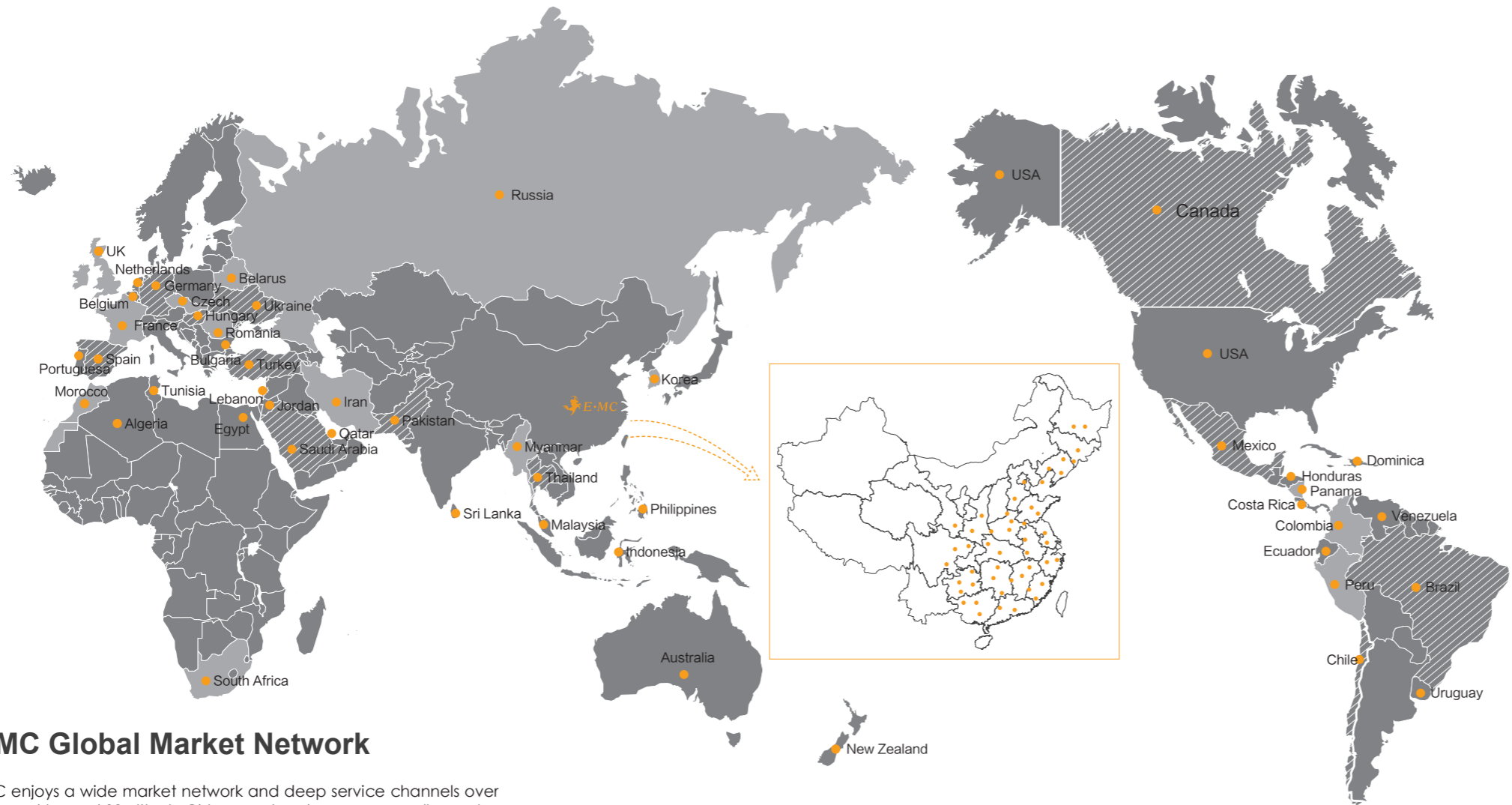

## E-MC Global Market Network

E-MC enjoys a wide market network and deep service channels over 117 countries and 82 cities in China, most customers can easily receive E-MC high quality products and service very conveniently.

### Overseas market

America	Chile	Ecuador	Asia	Jordan	Malaysia	Europe	Czech	Belarus	Africa	Oceania
USA	Brazil	Colombia	Iran	Saudi Arabia	Pakistan	Germany	Belgium	Romania	South Africa	New Zealand
Canada	Uruguay	Panama	Indonesia	Philippines	Sri Lanka	Netherlands	Spain	Turkey	Morocco	Australia
Mexico	Dominica		Korea	Qatar		France	Hungary	Bulgaria	Tunisia	
Peru	Costa Rica		Myanmar	Lebanon		Sweden	Russia	Portuguesa	Algeria	
Honduras	Venezuela		Thailand			UK	Ukraine		Egypt	

### Domestic market

Quanzhou	Xiamen	Shantou	Suzhou	Yancheng	Hefei
Kunming	Ningbo	Jinhua	Dalian	Changzhou	Luan
Chengdu	Foshan	Yangzhou	Xuzhou	Haerbing	Yantai
Chongqing	Zhoushan	Zhuhai	Zhenjiang	Shanghai	Luoyang
Guizhou	Guangzhou	Nanjing	Zhengzhou	Changsha	Zibo
Hangzhou	Fuzhou	Shenzhen	Dongguan	Tianjin	Qingdao
Wuhan	Shenyang	Jinan	Jining	Shijiazhuang	...

## From now to the future

From now to the future, E-MC highlights 'innovation' as the company strategy, follow up the core idea of 'Innovation creates value', sticks to the production-study-research combination developing way, working to be global leading automation solution platform.

E-MC continuously offers ingenious product, critiqued process and meticulous service, try the best to create maximum value for customers, lift efficiency for society and make high contribution to automation industry.

Innovating forever, from good to great!

Global Service Hotline  
0086-574-88847888

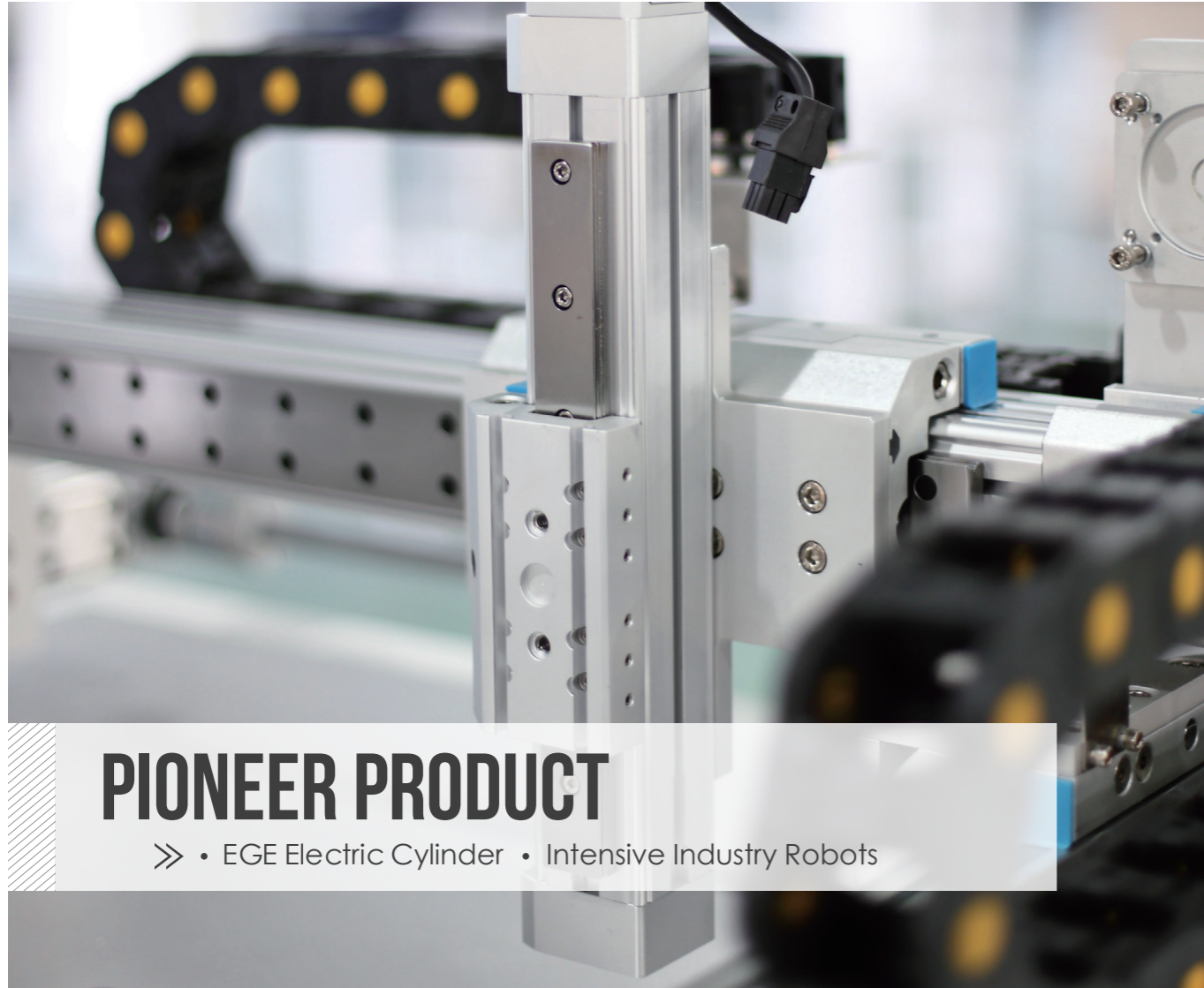

## PIONEER PRODUCT

» • EGE Electric Cylinder • Intensive Industry Robots

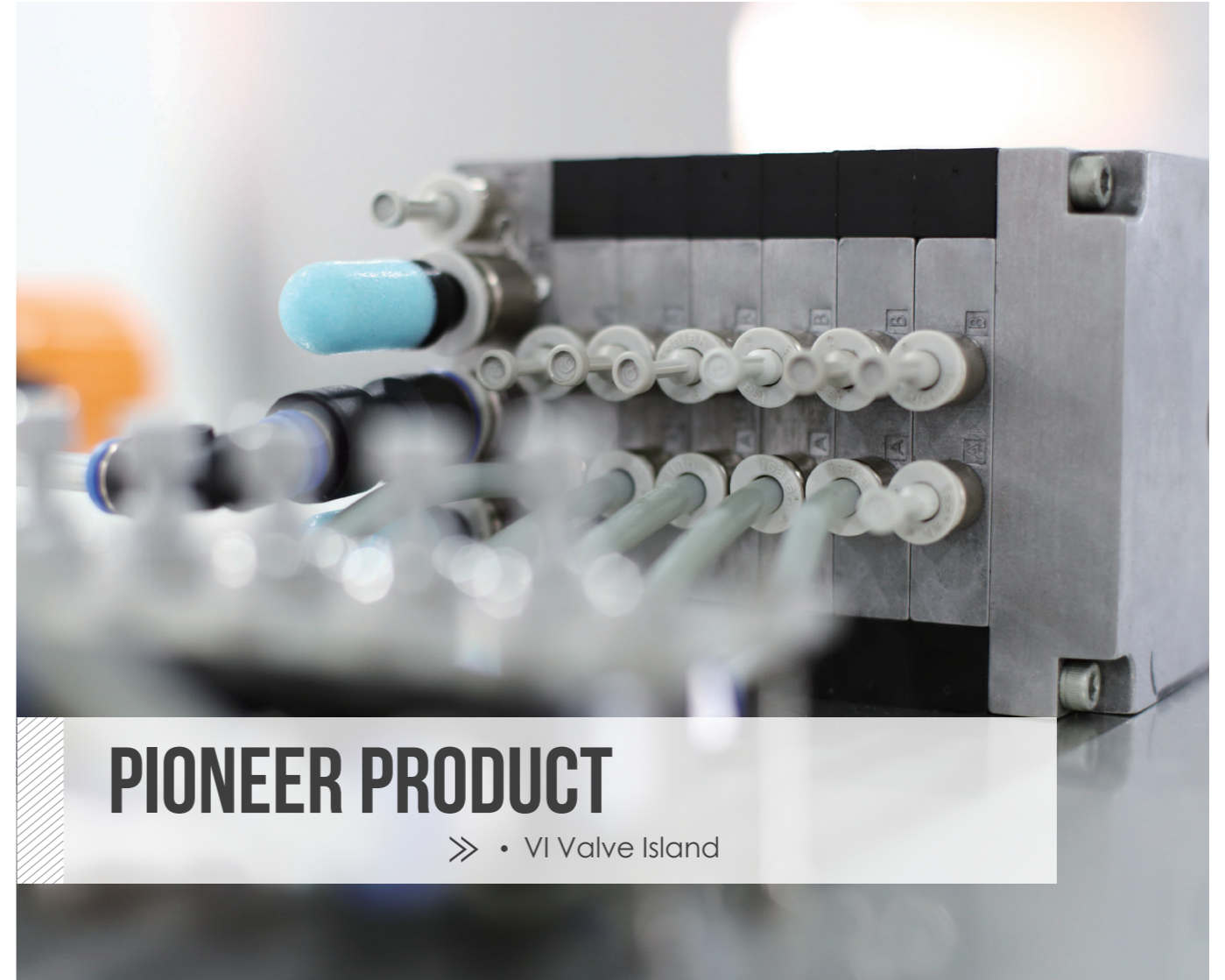

## PIONEER PRODUCT

» • VI Valve Island

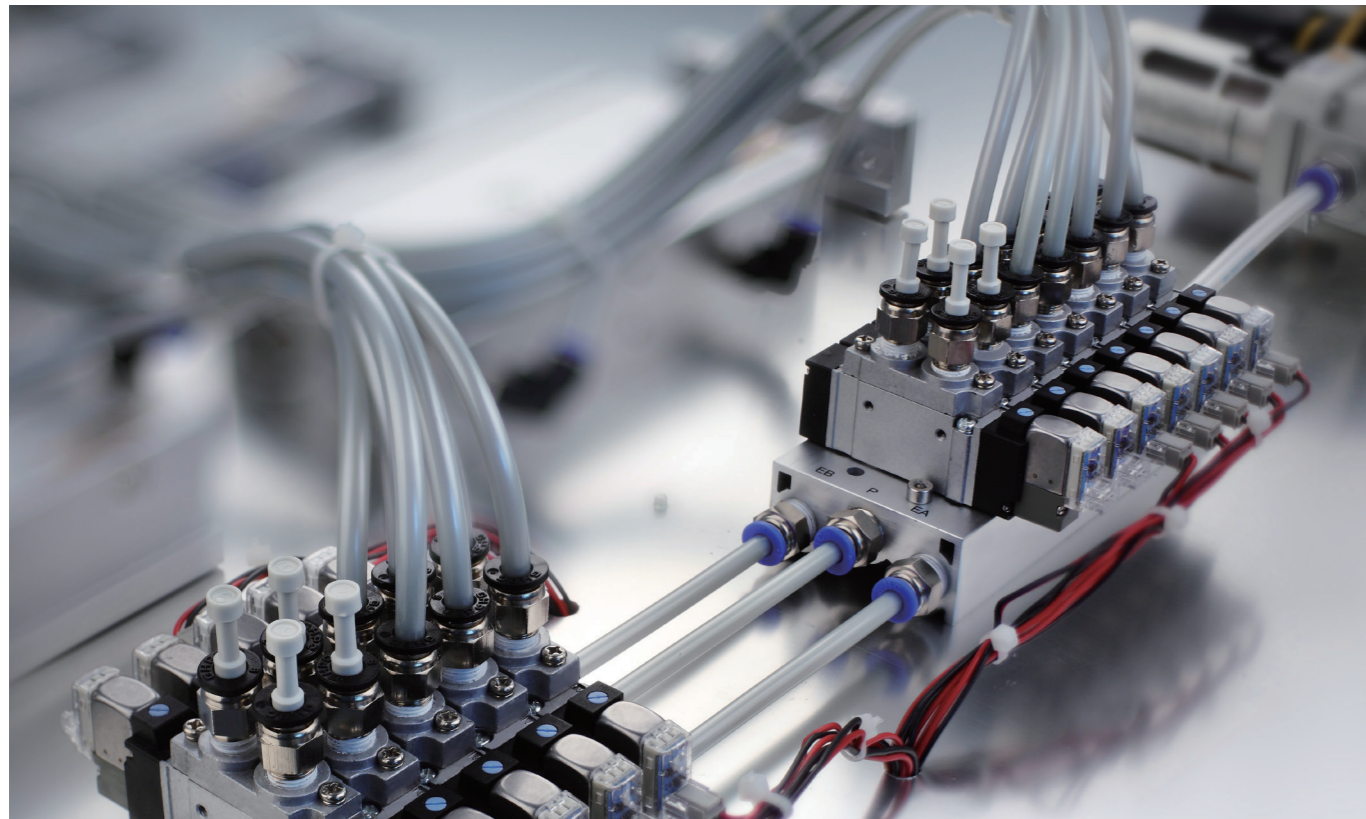

## PIONEER PRODUCT

» • CC compact Low Power Solenoid Valve

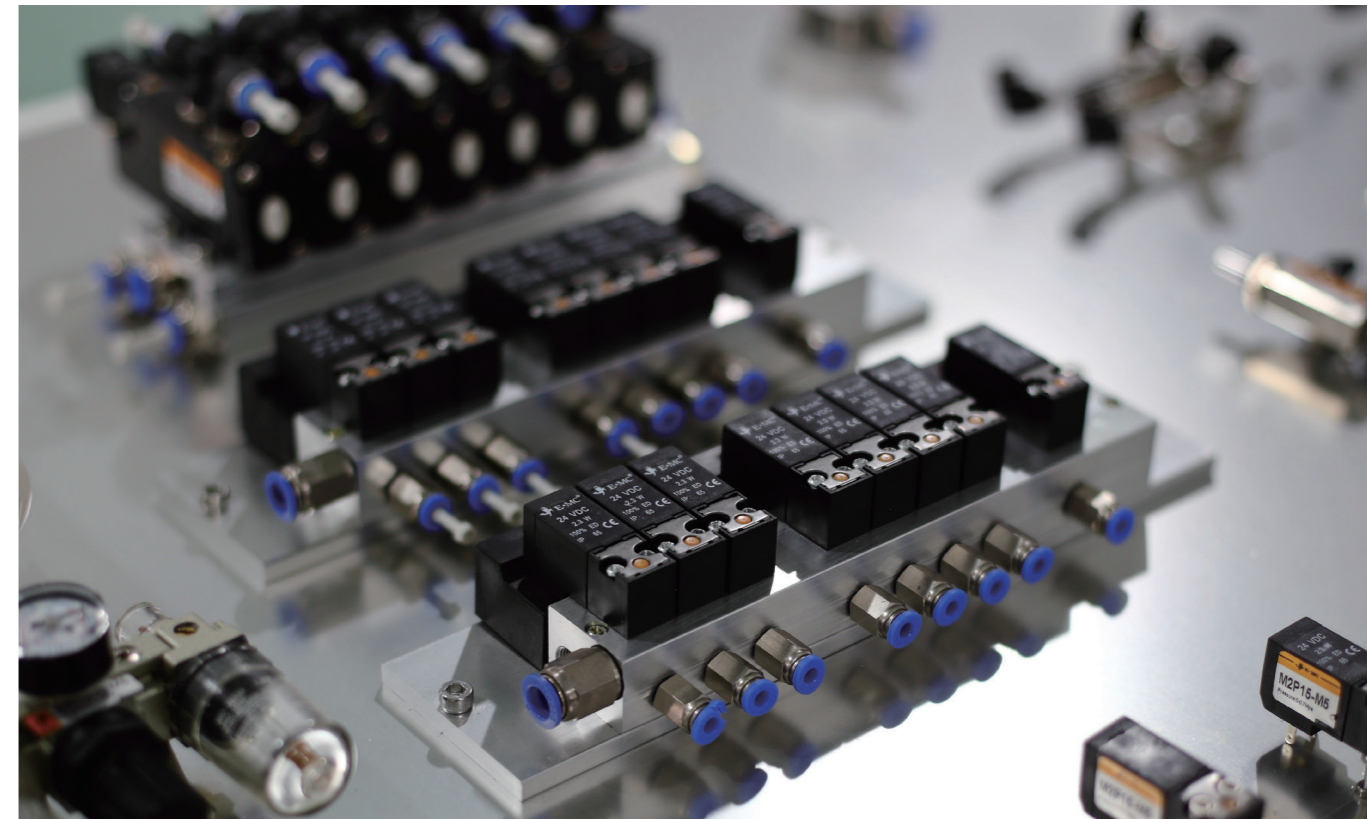

## PIONEER PRODUCT

» • M2P15 . M2P10 Micro Solenoid Valve



## PIONEER PRODUCT

» • SHC Pneumatic Gripper



## INNOVATIVE PRODUCT

» • EXS Double Shaft Cylinder • SG Three Shaft Cylinder







CORE PRODUCT >>

Technology and process innovation on classic products

Standard cylinder

FVBC / VBC

- All PU sealing system
- 200KM terrific loaded stroke life
- Strong guiding design with high concentricity
- Bronze bearing with much better lateral loading
- Strengthened cushion design, soft ending
- Double cushioning system

Compact cylinder

SD / SQ / SE

- 800KM long loaded stroke life
- Strong guiding design with high concentricity
- Bronze bearing with much better lateral loading
- Special rotary riveting structure for piston rod
- Back cover pressing technology
- Imported sealing
- Horizontal machining center manufacturing

Mini cylinder

RAL / RAS / IAS

- Simultaneously manufacturing for front and back cover with turn-milling machine
- Sole machine manufacturing and simultaneously riveted with barrel to make sure high concentricity
- Strong guiding with high concentricity for better lateral loading
- Multi-levels crimping technics to guarantee stability

Double shaft cylinder

EXS

- Simultaneously machining in Horizontal machining center for body
- High non-return precision, low piston rod deflection, applied in high precision positioning
- High bending resistance and tensional strength, great lateral loading performance
- Elongated slide supporting guide, lubrication free
- All mounting holes available at 3 sides, for more convenience

Three shaft cylinder

SG

- Simultaneously machining in Horizontal machining center for body
- Linear bearing or bronze bearing guided, high tensional strength and great lateral loading performance
- Steel ball linear bearing: better applied for pneumatic cylinder lifting job, or occasions requiring high precision and loading capability, especially suitable for low friction working cases; bronze slide bearing: better applied for pneumatic cylinder to do lateral load working, like stopping, it increase 2 times lateral impact, with stronger tension rigidity

Y type pneumatic gripper

SHC

- Simultaneously machining in Horizontal machining center for body
- Single piston structure, with higher gripping torques
- Easier to adjust gripper respond speed with adjustable flow valve equipped
- Wider application with suitable gripping angle
- High precision positioning, more accurate and reliable gripping

FVBC / FXBC Series Standard Cylinder

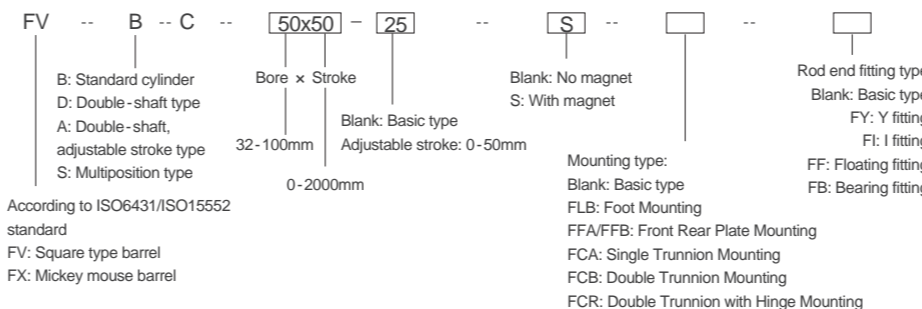
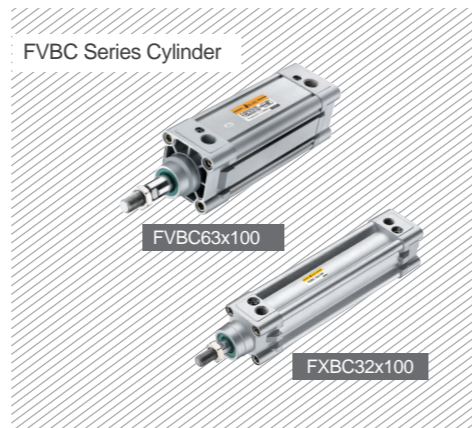

How to Order?

Order Example:

FV series Square type, Standard Type, 32mm bore, 50mm stroke, with magnet, Model: FVBC 32 x 50-S  
FX series Mickey mouse type, Standard Type, 63mm bore, 150mm stroke, Model: FXBC 63 x 150

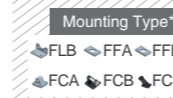

Specifications

Bore size(mm)	32	40	50	63	80	100
Acting type	Double Acting					
Working medium	Clean Air (25 μ filtration)					
Mounting type	FFA FFB FCA FCB FLB FCR					
Rod end fitting Type	FY FI FF FB					
Working pressure (Bar)	1~10					
Guaranteed pressure (Bar)	15					
Working temperature ( )	-5~70					
Speed range (mm/s)	50~800					
Cushion type	Adjustable Cushion					
Cushion stroke (mm)	27	30	36	40	50	
Port Size	G1/8	G1/4	G3/8	G1/2		

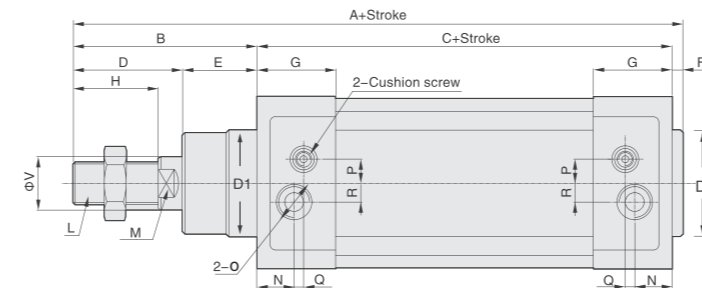

Main dimensions

Bore size(mm)	A	B	C	D	E	F	G	H	I	J	K	L	O	N	P	Q	R	V	M	D1
32	145	48	94	29	19	3	27.5	22	32.5	46.5	M6	M10x1.25	G1/8	13	6	6	5.5	12	10	30
40	162.5	54	105	33	21	3.5	32	24	38	54	M6	M12x1.25	G1/4	17	8.5	7.5	6	16	13	35
50	178.5	69	106	42	27	3.5	31	32	46.5	64	M8	M16x1.5	G1/4	15.5	9.5	6.5	7.5	20	17	40
63	194	69	121	42	27	4	33	32	56.5	75	M8	M16x1.5	G3/8	16.5	11.5	7.5	7.5	20	17	45
80	218	86	128	51.3	34.7	4	36	40	72	93	M10	M20x1.5	G3/8	16.4	12.1	10.5	8.3	25	22	45
100	233	91	138	53	38	4	39	40	89	110	M10	M20x1.5	G1/2	18.8	12.1	8	8.3	25	22	55

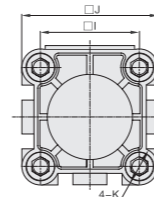

Same Size:  
No magnet / With magnet.

VBC / LBC Series Standard Cylinder

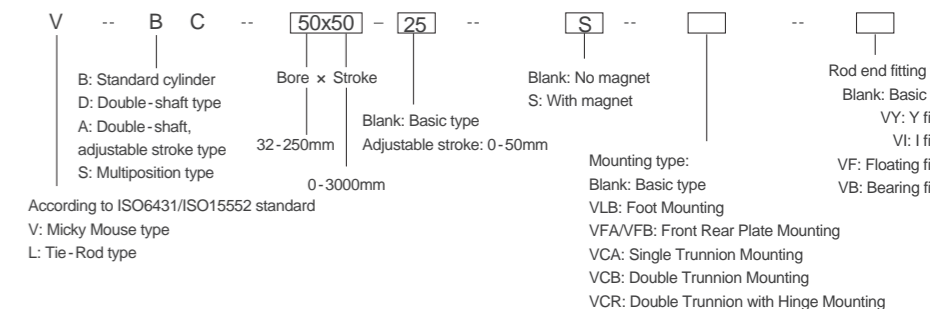

How to Order?

Order Example:

V series Micky Mouse type, Double-shaft with adjustable stroke 20mm, 50mm bore, 100mm stroke, Model: VAC 50 x 100-20  
L series Tie-rod type, standard type, 32mm bore, 50mm stroke, with magnet, Model: LBC 32 x 50-S



Specifications

Bore size(mm)	32	40	50	63	80	100	125	160	200	250
Acting type	Double Acting									
Working medium	Clean Air (25 μ filtration)									
Mounting type	VFA VFB VCA VCB VCR VLB									
Rod end fitting Type	VY VI VF VB									
Working pressure (Bar)	1~10									
Guaranteed pressure (Bar)	15									
Working temperature ( )	-5~70									
Speed range (mm/s)	50~800									
Cushion type	Adjustable Cushion									
Cushion stroke (mm)	27	30	36	40	50					
Port Size	G1/8	G1/4	G3/8	G1/2	G3/4	G1				

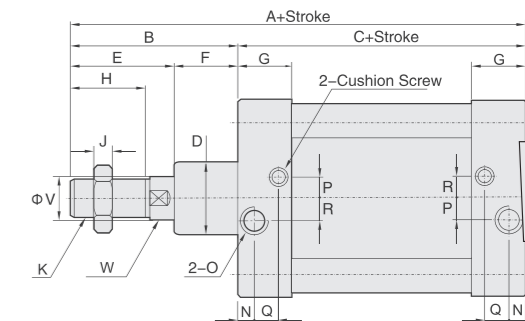

Main dimensions

Bore size(mm)	A	B	C	D	E	F	G	H	I	J	K	L	N	O	P	Q	R	S	T	V	W	X	Y	
32	145	48	94	27	19	29	19	27.5	22	17	6	M10x1.25	M6	13	G1/8	6	6	5.5	47	32.5	12	10	3	30
40	162.5	54	105	32.5	33	21	32	24	17	7	M12x1.25	M6	17	G1/4	8.5	7.5	6	53	38	16	13	3.5	35	
50	178.5	69	106	37.5	42	27	31	32	23	8	M16x1.5	M8	15.5	G1/4	9.5	6.5	7.5	65	46.5	20	17	3.5	40	
63	194	69	121	40	42	27	33	32	23	8	M16x1.5	M8	16.5	G3/8	11.5	7.5	7.5	75	56.5	20	17	4	45	
80	218	86	128	42.5	53	33	33	40	27	10	M20x1.5	M10	16.5	G3/8	13.5	7.5	9	95	72	25	22	4	45	
100	233	91	138	48	55	36	37	40	27	10	M20x1.5	M10	18.5	G1/2	13.5	8	9.5	115	89	25	22	4	55	
125	279	119	160	60	74	45	46	54	41	13.5	M27x2	M12	23	G1/2	14	12	14	140	110	32	27	-	-	
160	332	152	180	65	94	58	50	72	55	18	M36x2	M16	25	G3/4	20	12	15	180	140	40	36	-	-	
200	347	167	180	75	110	57	50	72	55	18	M36x2	M16	25	G3/4	0	0	0	220	175	40	36	-	-	
250	401	191	200	80	124	67	52	84	65	20	M42x2	M20	26.5	G1	21	7.5	20.5	270	220	50	45	10	90	

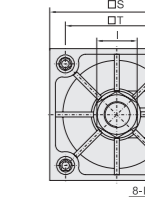

Same Size:  
No magnet / With magnet.

## TBC/XBC Series Standard Cylinder

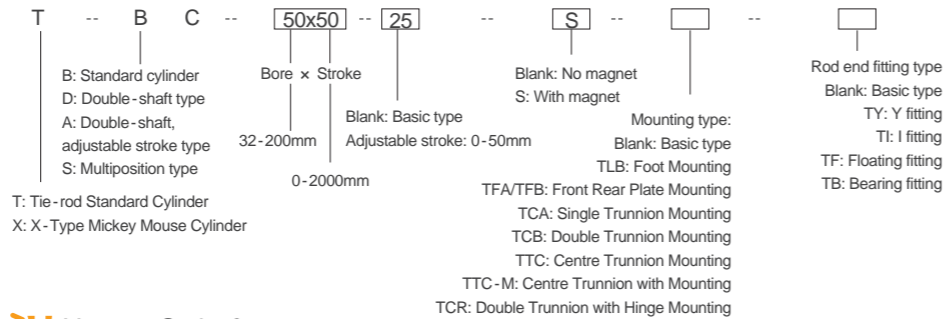
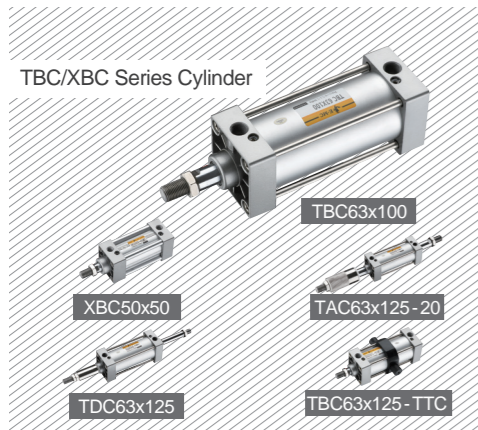

### How to Order?

#### Order Example:

T series Cylinder, standard type, 32mm bore, 50mm stroke, with magnet, Model: TBC 32 x 50-S  
X series Cylinder, Double-shaft with adjustable stroke 20mm, 40mm bore, 200mm stroke, Model: XAC 40 x 200-20



### Specifications

Bore size(mm)	32	40	50	63	80	100	125	160	200
Acting type	Double Acting								
Working medium	Clean Air (25 μ filtration)								
Mounting type	TFA TFB TCA TCB TLB TTC TTC-M TCR								
Rod end fitting Type	TY TI TF TB								
Working pressure (Bar)	1~10								
Guaranteed pressure (Bar)	15								
Working temperature (°C)	-5~70								
Speed range (mm/s)	50~800								
Cushion type	Adjustable Cushion								
Cushion stroke (mm)	24			32					
Port Size	G1/8	G1/4	G3/8	G1/2	G3/4				

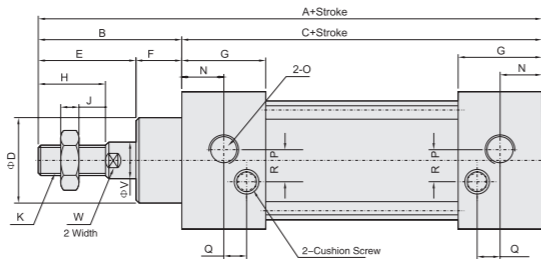

### Main dimensions

Bore size(mm)	A	B	C	D	E	F	G	H	I	J	K	L	M	N	O	P	Q	R	S	T	V	W
32	140	47	93	25	32	15	27.5	22	17	6	M10X1.25	M6X1	9.5	13.75	G1/8	3.5	7.5	7	45	33	12	10
40	142	49	93	32	34	15	27.5	24	17	7	M12X1.25	M6X1	9.5	13.5	G1/4	6	7.5	9	50	37	16	14
50	150	57	93	35	42	15	27.5	32	23	8	M16X1.5	M6X1	9.5	13.5	G1/4	8.5	8.2	9	62	47	20	17
63	153	57	96	35.5	42	15	27.5	32	23	8	M16X1.5	M8X1.25	13	13.5	G3/8	7	6.5	8.5	75	56	20	17
80	182	75	107	47	54	21	33	40	30	10	M20X1.5	M10X1.5	16	16.5	G3/8	7	8	10	94	70	25	22
100	188	75	113	47	54	21	33	40	30	10	M20X1.5	M10X1.5	16	16.5	G1/2	7.5	8	13	112	84	25	22

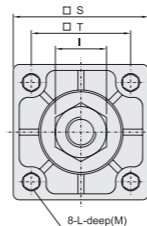

Same Size:  
No magnet / With magnet.

## IAS Series Mini Cylinder

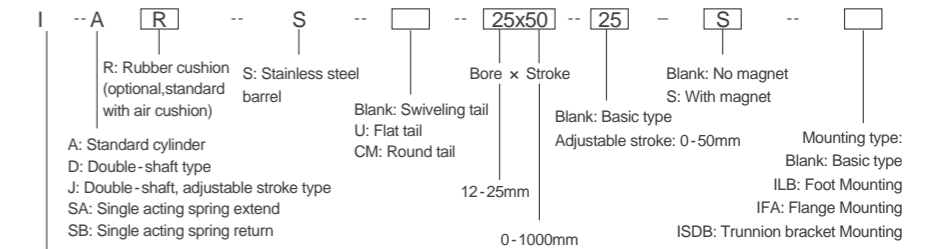

### How to Order?

#### Order Example:

I series Cylinder Stainless steel barrel, 12mm bore, 50mm stroke, Model: IAS 12 x 50  
I series Cylinder Stainless steel barrel, Double-shaft type, 25mm bore, 70mm stroke, with magnet, Model: IDS 25 x 70-S



### Specifications

Bore size(mm)	12	16	20	25
Acting type	Double Acting/Single Acting			
Working medium	Clean Air (25 μ filtration)			
Mounting type	IFA ISDB ILB			
Working pressure (Bar)	1~9.0			
Max. working pressure(Bar)	13.5			
Working temperature (°C)	0~80(Dry air~20)			
Speed range (mm/s)	10~1000			
Cushion type	16~25mm bore with adjustable cushion, 12mm rubber cushion			
Material	Stainless steel barrel			
Port Size	M5 x 0.8			G1/8

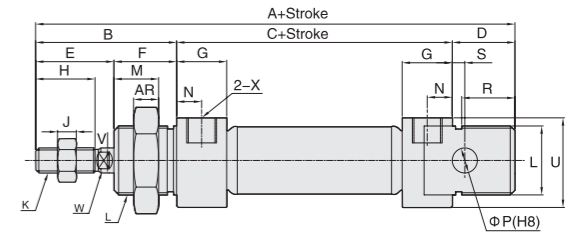

### Main dimensions

Bore size(mm)	A	B	C	D	E	F	G	H	I	J	K	L	M	N	P	Q	R	S	U	V	W	X	AR	AX	AY
12	105	38	50	17	21	17	10.5	14.5	10	5	M6	M16x1.5	12	8	6	12	15	3	18.3	6	5	M5	8	27	24
16	112	39	56	17	22	17	11	14.5	10	5	M6	M16x1.5	12	6	6	12	13.5	4	21	6	5	M5	8	27	24
20	133	45	68	20	25	20	16	18	14	6	M8	M22x1.5	15	8	8	16	17	3	28.6	8	6	G1/8	10	35	31
25	142	52	68	22	30	22	16	20	17	6	M10x1.25	M22x1.5	15	8	8	16	18.5	3.5	28.6	10	8	G1/8	10	35	31

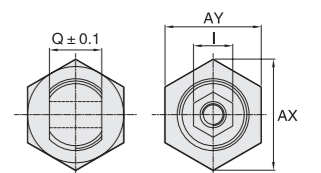

## RAL/RAS Series Mini Cylinder

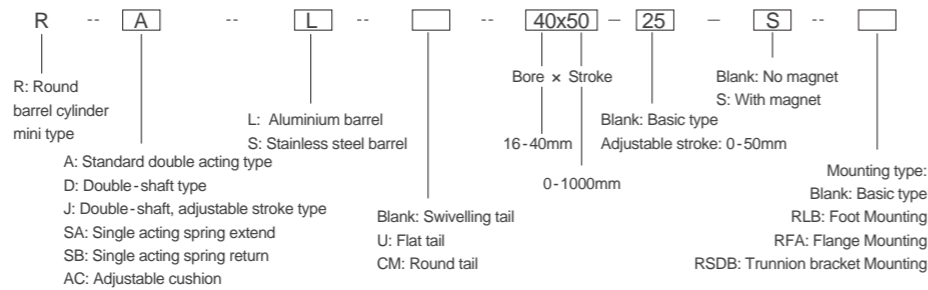

### How to Order?

#### Order Example:

R series cylinder with aluminium barrel, Standard type, 16mm bore, 50mm stroke, Model: RAL 16 x 50  
 R series cylinder with stainless steel barrel, Adjustable cushion type, 20mm bore, 80mm stroke, with magnet, Model: RACS 20x80-S

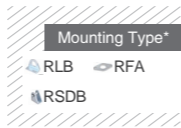

### Specifications

Bore size(mm)	16	20	25	32	40
Acting type	Double Acting/Single Acting				
Working medium	Clean Air (25 μ filtration)				
Mounting type	RFA RSDB RLB				
Working pressure (Bar)	1~10				
Guaranteed pressure (Bar)	15				
Working temperature (°C)	-5~70				
Speed range (mm/s)	50~800				
Cushion type	Standard type Anti-bump cushion				
Cushion type	- Adujstable cushion				
Port Size	M5 x 0.8		G1/8		

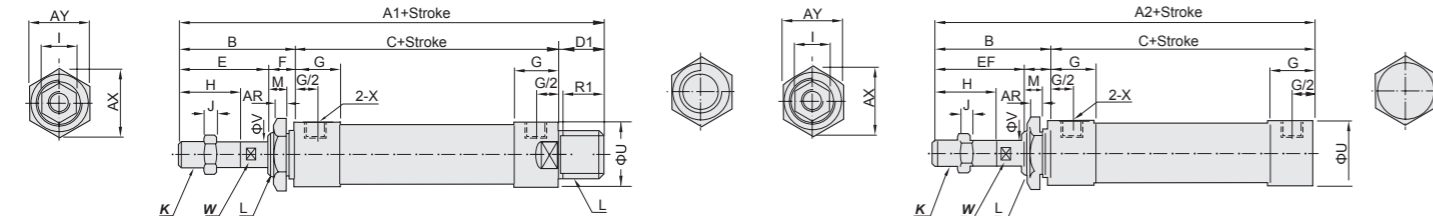

## RAL Series Mini Cylinder

### Main dimensions

Bore size (mm)	A	A1	A2	B	C	D	D1	E	F	G	H	I	J	K	L	M	P	Q	R	R1	S	U	V	W	X	AR	AX	AY
16	106	-	-	36	56	14	-	22	14	11	16	10	6	M6X1	M16X1.5	12.5	6	12	12.5	-	7	20	6	5	M5	6	27	24
20	131	122	110	40	70	21	12	28	12	16	21	12	6	M8X1.25	M22X1.5	10	8	16	19	10	12	29	8	6	G1/8	7	33	29
25	135	128	114	44	70	21	14	30	14	16	22	17	6	M10X1.25	M22X1.5	12	8	16	19	12	12	34	10	8	G1/8	7	33	29
32	141	128	114	44	70	27	14	30	14	16	22	17	6	M10X1.25	M24X2.0	12	10	16	25	12	15	39.5	12	10	G1/8	8	37	32
40	165	152	138	46	92	27	14	32	14	22	24	17	7	M12X1.25	M30X2.0	12	12	20	25	12	15	49	16	14	G1/4	9	47	41

## RAS Series Mini Cylinder

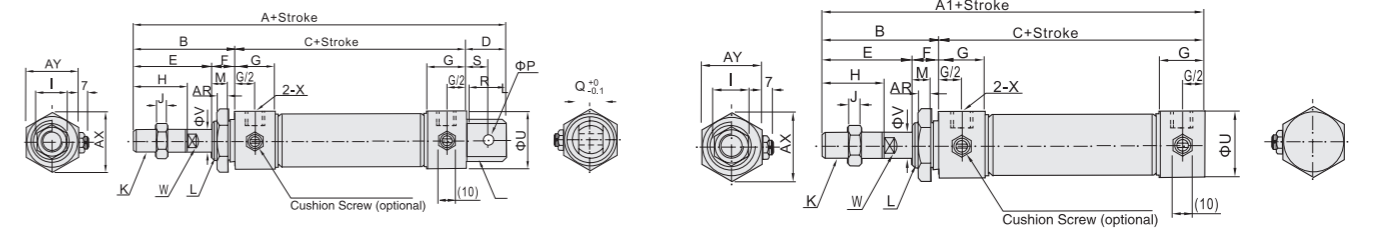

### Main dimensions

Bore size (mm)	A	A1	B	C	D	E	F	G	H	I	J	K	L	M	P	Q	R	S	U	V	W	X	AR	AX	AY
16	114	98	36	60	16	22	16	10	16	10	5	M6X1	M16X1.5	14.5	6	12	14.5	9	21	6	5	M5	6	25	22
20	137	116	40	76	21	28	12	16	20	12	6	M8X1.25	M22X1.5	10	8	16	19	12	27	8	6	G1/8	7	33	29
25	141	120	44	76	21	30	14	16	22	17	6	M10X1.25	M22X1.5	12	8	16	19	12	30	10	8	G1/8	7	33	29
32	147	120	44	76	27	30	14	16	22	17	6	M10X1.25	M24X2.0	12	10	16	25	15	35	12	10	G1/8	8	37	32
40	149	122	46	76	27	32	14	16.7	24	17	7	M12X1.25	M30X2.0	12	12	20	25	15	41.6	16	14	G1/8	9	47	41

## SE Series European Standard Compact Cylinder

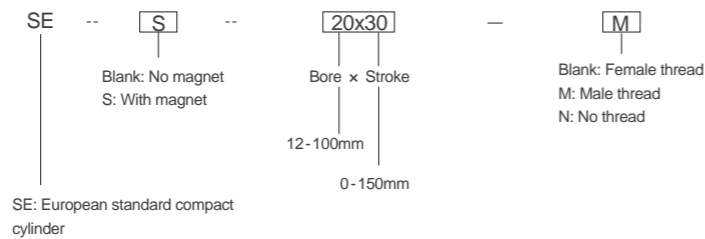
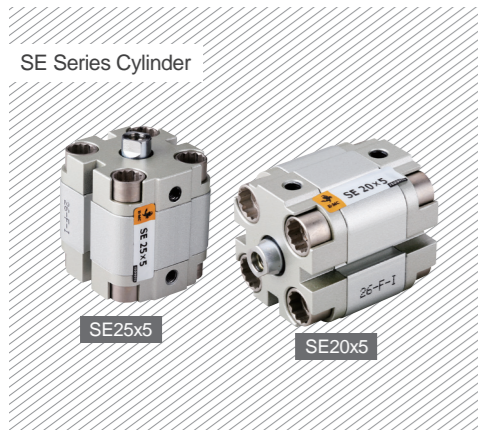

### How to Order?

#### Order Example:

SE type European standard compact cylinder, no magnet, 20mm bore, 30mm stroke, with female thread, Model: SE20\*30  
SE type European standard compact cylinder, with magnet, 32mm bore, 100mm stroke, with male thread, Model: SE32\*100-M

### Specifications

Bore size(mm)	12	16	20	25	32	40	50	63	80	100
Acting type	Double Acting; Single acting: with spring return/with spring extend									
Working medium	Clean Air (25 μ filtration)									
working pressure (Bar)	Double acting		1~10							
Max.working pressure (Bar)	Single acting		2~10							
Working temperature ( )	-5~70									
Speed range (mm/s)	Double acting		30~500			30~350		30~250		
Cushion type	Single acting		30~500							
Port Size	M5x0.8					G1/8			G1/4	

### Main dimensions

Bore size(mm)	Standard										With magnet			E		F	G	K1	L	M	N	N3	O	P	P3	P4	R	S	T1	T2	U	V	W	X	Y	
	A	B	C	D	E	F	G	H	I	J	K	L	M	N	O																					P
12	6	4	30	18	29	7	M5X0.8	3	6	M4X0.7	11.5	18.5	38	42.5	4.5	5	M3X0.5	3.3	8	1.5																
16	6	4	30	18	29	7	M5X0.8	3	8	M4X0.7	11.5	18.5	38	42.5	4.5	6	M4X0.7	4.5	10	1.5																
20	6	4	37.5	22	36	7	M5X0.8	3	10	M5X0.8	11.5	18.5	38	42.5	4.5	8	M5X0.8	5.5	12	2																
25	6	4	41.5	26	40	7	M5X0.8	4	10	M5X0.8	11.5	18.5	39.5	45	5.5	8	M5X0.8	5.5	12	2																
32	6	4	52	32	50	8	PS1/8	4.5	12	M6X1.0	14	21.5	44.5	50.5	6	10	M6X1.0	6.5	14	2.6																
40	6	4	62.5	42	60	8	PS1/8	4.5	12	M6X1.0	14	21.5	45.5	52	6.5	10	M6X1.0	6.5	14	2.6																
50	6	4	71	50	68	8	PS1/8	5	16	M8X1.25	14	22	45.5	53	7.5	13	M8X1.25	8.5	16	3.3																
63	8	4	91	62	87	8	PS1/8	5	16	M10X1.5	15	24.5	50	57.5	7.5	13	M8X1.25	8.5	16	3.3																
80	8	4	111	82	107	8.5	PS1/8	5.5	20	M10X1.5	16	27.5	56	64	8	17	M10X1.5	10.5	20	4.7																
100	8	4	133	103	128	10.5	PS1/4	7.5	25	M10X1.5	19	32.5	66.5	76.5	10	22	M12X1.75	12.5	24	6.1																

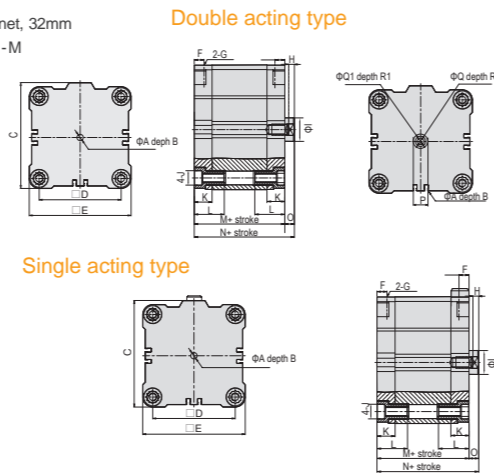

### Single acting type

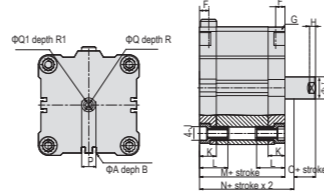

## SD Series Compact Cylinder

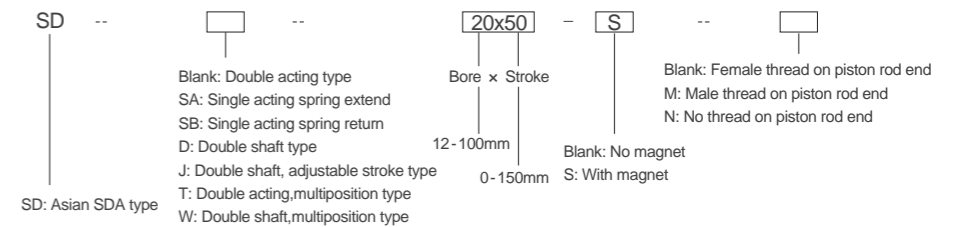

### How to Order?

#### Order Example:

SD type Compact Cylinder, basic type, 40mm bore, 75mm stroke, Female thread on piston rod end, Model: SD 40 × 75  
SD type Compact Cylinder, Single acting spring extend type, 12mm bore, 30mm stroke, with magnet, Male thread on piston rod end, Model: SDSA 12 × 30-SM

### Specifications

Bore size(mm)	12	16	20	25	32	40	50	63	80	100
Acting type	Double Acting; Single acting: with spring return/with spring extend									
Working medium	Clean Air (25 μ filtration)									
working pressure (Bar)	Double acting		1~10							
Max.working pressure (Bar)	Single acting		2~9.0							
Working temperature ( )	-5~70									
Speed range (mm/s)	Double acting		30~500			30~350		30~250		
Cushion type	Single acting		100~500							
Port Size	M5x0.8					G1/8		G1/4		G3/8

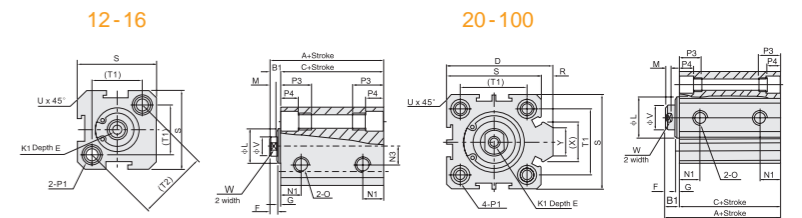

### Main dimensions

Bore size	Standard										With magnet			E		F	G	K1	L	M	N	N3	O	P	P3	P4	R	S	T1	T2	U	V	W	X	Y
	A	B	C	A	B	C	D	Stroke 10	Stroke > 10																										
12	22	5	17	32	5	27	-	6	4	1	M3*0.5	10.2	2.8	6.3	6	M5x0.8	Double side:	6.5/Thread M5*0.8/Through Hole:	4.2	12	4.5	-	25	16.2	23	1.6	6	5	-	-	-	-	-		
16	24	5.5	18.5	34	5.5	28.5	-	6	4	1.5	M3*0.5	11	2.8	7.3	6.5	M5x0.8	Double side:	6.5/Thread M5*0.8/Through Hole:	4.2	12	4.5	-	29	19.5	28	1.6	6	5	-	-	-	-	-		
20	25	5.5	19.5	35	5.5	29.5	36	8	4	1.5	M4*0.7	15	2.8	7.5	-	M5x0.8	Double side:	6.5/Thread M5*0.8/Through Hole:	4.2	14	4.5	2	34	24	-	2.1	8	6	11.3	10					
25	27	6	21	37	6	31	42	10	4	2	M5*0.8	17	2.8	8	-	M5x0.8	Double side:	8.2/Thread M6*1.0/Through Hole:	4.6	15	5.5	2	40	28	-	3.1	10	8	12	10					
32	31.5	7	24.5	41.5	7	34.5	50	12	4	3	M6*1	22	2.8	9	-	G1/8	Double side:	8.2/Thread M6*1.0/Through Hole:	4.6	16	5.5	6	44	34	-	2.15	12	10	18.3	15					
40	33	7	26	43	7	36	58.5	12	4	3	M8*1.25	28	2.8	10	-	G1/8	Double side:	10/Thread M8*1.25/Through Hole:	6.5	20	7.5	6.5	52	40	-	2.25	16	14	21.3	16					
50	37	9	28	47	9	38	71.5	15	5	4	M10*1.5	38	2.8	10.5	-	G1/4	Double side:	11/Thread M8*1.25/Through Hole:	6.5	25	8.5	9.5	62	48	-	4.15	20	17	30	20					
63	41	9	32	51	9	42	84.5	15	5	4	M10*1.5	40	2.8	11.8	-	G1/4	Double side:	11/Thread M8*1.25/Through Hole:	6.5	25	8.5	9.5	75	60	-	3.15	20	17	28.7	20					
80	52	11	41	62	11	51	104	15	20	6	M14*1.5	45	4	14.5	-	G3/8	Double side:	14/Thread M12*1.75/Through Hole:	9.2	25	10.5	10	94	74	-	3.65	25	22	36	26					
100	63	12	51	73	12	61	124	18	20	7	M18*1.5	55	4	20.5	-	G3/8	Double side:	17.5/Thread M14*2/Through Hole:	11.3	30	13	10	114	90	-	3.65	32	27	35	26					

## SD Series Compact Cylinder

### Main dimensions

#### SDD Series Compact Cylinder

Bore size (mm)	Standard		With magnet		E		B1	F	G	K1	L	N1	
	A	C	A	C	S	10						S > 10	S=5
12	27	17	37	27	6		5	4	1	M3x0.5	10.2	5.5	6.3
16	29.5	18.5	39.5	28.5	6		5.5	4	1.5	M3x0.5	11	6.5	7.3
20	30.5	19.5	40.5	29.5	8(S=5 6.5)		5.5	4	1.5	M4x0.7	15	7.5	7.5
25	33	21	43	31	10(S=5 7)		6	4	2	M5x0.8	17	8	8
32	38.5	24.5	48.5	34.5	8	12	7	4	3	M6x1	22	8	9
40	40	26	50	36	8	12	7	4	3	M8x1.25	28	8	10
50	46	28	56	38	8	15	9	5	4	M10x1.5	38	8	10.5
63	50	32	60	42	10	15	9	5	4	M10x1.5	40	9.5	11.8
80	63	41	73	51	13	20	11	6	5	M14x1.5	45	11.5	14.5
100	75	51	85	61	18	20	12	7	5	M18x1.5	55	16	20.5

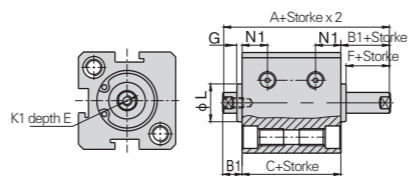

12-16

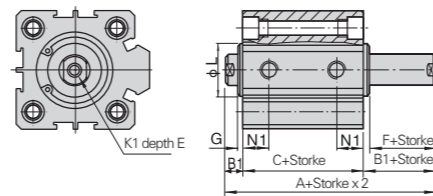

20-100

#### SDW Series Compact Cylinder

Bore size (mm)	Standard		With magnet		B1	D	E	F	G	K1	L	M	N2		N1			
	A	C0	C1	A									C0	C1	S=5	S > 5	S=5	S > 5
12	44	34	17	64	54	27	5	-	6	4	1	M3x0.5	10.2	3	7.5	7.5	5	
16	48	37	18.5	68	57	28.5	5.5	-	6	4	1.5	M3x0.5	11	3	8	8	5.5	5.5
20	50	39	19.5	70	59	29.5	5.5	36	8	4	1.5	M4x0.7	13	3	9	9	5.5	5.5
25	54	42	21	74	62	31	6	42	10	4	2	M5x0.8	17	3	9.2	9.2	5.5	5.5
32	63	49	24.5	83	69	34.5	7	50	12	4	2.4	M6x1	22	3	9	9	6.5	9
40	66	52	26	86	72	36	7	58.5	12	4	3	M8x1.25	28	3	9.5	9.5	7.5	7.5
50	74	56	28	94	76	38	9	71.5	15	5	4	M10x1.5	38	3	8	10.5	8	10.5
63	82	64	32	102	84	42	9	84.5	15	5	4	M10x1.5	40	3	9.5	12	9.5	11
80	104	82	41	124	102	51	11	104	20	6	5	M14x1.5	45	4	11.5	14.5	11.5	14.5
100	126	102	51	146	122	61	12	124	20	7	5	M18x1.5	55	4	16	20.5	16	20.5

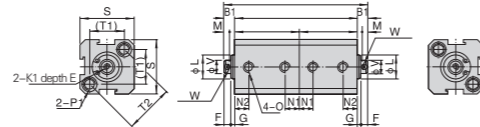

12-16

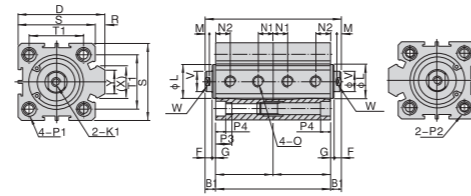

20-100

Bore size (mm)	O	X	Y	W	P1	P2	P3	P4	R	S	T1	T2	V
16	M5x0.8	-	-	5	6.5 / Tread M5x0.8 / Though hole: 4.2	-	12	4.5	-	29	19.8	28	6
20	M5x0.8	11.3	10	6	Double side: 6.5 / Tread M5x0.8 / Though hole: 4.2	Double side: 6.5 / Though hole: 5.2	14	4.5	2	34	24	-	8
25	M5x0.8	12	10	8	Double side: 8.2 / Tread M8x1.0 / Though hole: 4.6	Double side: 8.2 / Though hole: 6.2	15	5.5	2	40	28	-	10
32	PT1/8	18.3	15	10	Double side: 8.2 / Tread M8x1.0 / Though hole: 4.6	Double side: 8.2 / Though hole: 6.2	16	5.5	6	44	34	-	12
40	PT1/8	21.3	16	14	Double side: 10 / Tread M8x1.25 / Though hole: 6.5	Double side: 10 / Though hole: 8.2	20	7.5	6.5	52	40	-	16
50	PT1/4	30	20	17	Double side: 11 / Tread M8x1.25 / Though hole: 6.5	Double side: 11 / Though hole: 8.5	25	8.5	9.5	62	48	-	20
63	PT1/4	28.7	20	17	Double side: 11 / Tread M8x1.25 / Though hole: 6.5	Double side: 11 / Though hole: 8.5	25	8.5	9.5	75	60	-	20
80	PT3/8	36	26	22	Double side: 14 / Tread M12x1.75 / Though hole: 9.2	Double side: 14 / Though hole: 12.3	25	10.5	10	94	74	-	25
100	PT3/8	35	26	27	Double side: 17.5 / Tread M14x2 / Though hole: 11.3	Double side: 17.5 / Though hole: 14.2	30	13	10	114	90	-	32

## SD Series Compact Cylinder

### Main dimensions

#### SDT Series Compact Cylinder

Bore size (mm)	Standard		With magnet		B1	D	E	F	G	K1	L	M	N1		N2			
	A	C0	C1	A									C0	C1	S=5	S > 5	S=5	S > 5
12	39	34	17	59	54	27	5	-	6	4	1	M3x0.5	10.2	3	5	5	7.5	7.5
16	42.5	37	18.5	62.5	57	28.5	5.5	-	6	4	1.5	M3x0.5	11	3	5.5	5.5	8	8
20	44.5	39	19.5	64.5	59	29.5	5.5	36	8	4	1.5	M4x0.7	13	3	5.5	5.5	9	9
25	48	42	21	68	62	31	6	42	10	4	2	M5x0.8	17	3	5.5	5.5	9.2	9.2
32	56	49	24.5	76	69	34.5	7	50	12	4	2.4	M6x1	22	3	6.5	9	9	9
40	59	52	26	79	72	36	7	58.5	12	4	3	M8x1.25	28	3	7.5	7.5	9.5	9.5
50	65	56	28	85	76	38	9	71.5	15	5	4	M10x1.5	38	3	8	10.5	8	10.5
63	73	64	32	93	84	42	9	84.5	15	5	4	M10x1.5	40	3	9.5	11	9.5	12
80	93	82	41	113	102	51	11	104	20	6	5	M14x1.5	45	4	11.5	14.5	11.5	14.5
100	114	102	51	134	122	61	12	124	20	7	5	M18x1.5	55	4	16	20.5	16	20.5

Bore size (mm)	O	X	Y	W	P1	P2	P3	P4	R	S	T1	T2	V
16	M5x0.8	-	-	5	6.5 / Tread M5x0.8 / Though hole: 4.2	-	12	4.5	-	29	19.8	28	6
20	M5x0.8	11.3	10	6	Double side: 6.5 / Tread M5x0.8 / Though hole: 4.2	Double side: 6.5 / Though hole: 5.2	14	4.5	2	34	24	-	8
25	M5x0.8	12	10	8	Double side: 8.2 / Tread M8x1.0 / Though hole: 4.6	Double side: 8.2 / Though hole: 6.2	15	5.5	2	40	28	-	10
32	PT1/8	18.3	15	10	Double side: 8.2 / Tread M8x1.0 / Though hole: 4.6	Double side: 8.2 / Though hole: 6.2	16	5.5	6	44	34	-	12
40	PT1/8	21.8	16	14	Double side: 10 / Tread M8x1.25 / Though hole: 6.5	Double side: 10 / Though hole: 8.2	20	7.5	6.5	52	40	-	16
50	PT1/4	30	20	17	Double side: 11 / Tread M8x1.25 / Though hole: 6.5	Double side: 11 / Though hole: 8.5	25	8.5	9.5	62	48	-	20
63	PT1/4	28.7	20	17	Double side: 11 / Tread M8x1.25 / Though hole: 6.5	Double side: 11 / Though hole: 8.5	25	8.5	9.5	75	60	-	20
80	PT3/8	36	26	22	Double side: 14 / Tread M12x1.75 / Though hole: 9.2	Double side: 14 / Though hole: 12.3	25	10.5	10	94	74	-	25
100	PT3/8	35	26	27	Double side: 17.5 / Tread M14x2 / Though hole: 11.3	Double side: 17.5 / Though hole: 14.2	30	13	10	114	90	-	32

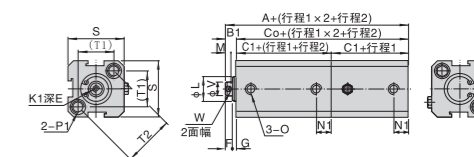

12-16

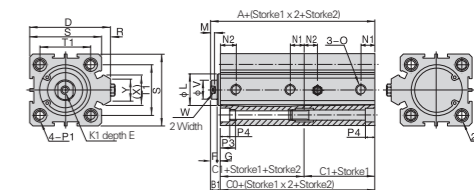

20-100

#### SDJ Series Compact Cylinder

Bore size (mm)	Standard		With magnet		E		B1	Q	G	J1	K1	K3	L	N1	
	A	C	A	C	S	10								S > 10	S=5
12	40	17	50	27	6		5	17	1	4	M3x0.5	M5x0.8	10.2	5.5	6.3
16	42.5	18.5	52.5	28.5	6		5.5	17	1.5	4	M3x0.5	M5x0.8	11	6.5	7.3
20	47.5	19.5	57.5	29.5	8(S=5 6.5)		5.5	21	1.5	5	M4x0.7	M6x1.0	15	7.5	7.5
25	54	21	64	31	10(S=5 7)		6	25	2	6	M5x0.8	M8x1.25	17	8	8
32	61.5	24.5	71.5	34.5	8	12	7	27	3	6	M6x1.0	M10x1.25	22	8	9
40	64	26	74	36	8	12	7	28	3	7	M8x1.25	M12x1.25	28	8	10
50	70	28	80	38	8	15	9	29	4	8	M10x1.5	M16x1.5	38	8	10.5
63	74	32	84	42	10	15	9	29	4	8	M10x1.5	M16x1.5	40	9.5	11.8
80	92.5	41	102.5	51	13	20	11	35.5	5	10	M14x1.5	M20x1.5	45	11.5	14.5
100	110.5	51	120.5	61	18	20	12	42.5	5	13.5	M18x1.5	M27x2.0	55	16	20.5

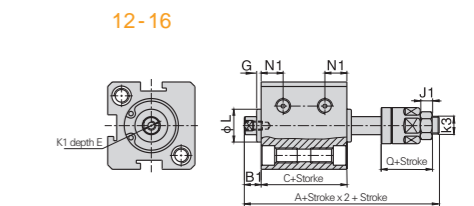

20-100

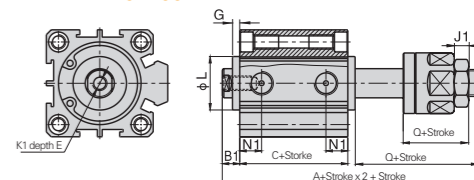

## SQ Series Compact Cylinder

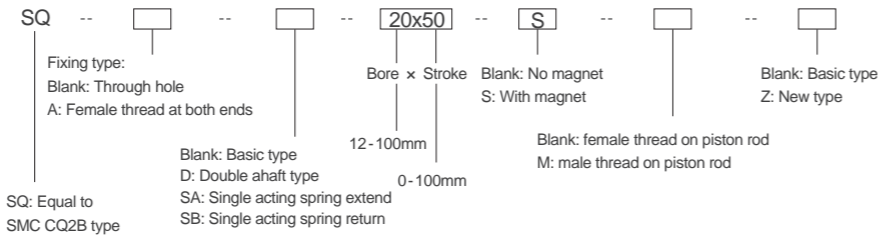

### How to Order?

#### Order Example:

SQ type compact cylinder, basic type, fixing type: through hole, 50mm bore, 85mm stroke, Model: SQ 50 x 85  
 SQ type compact cylinder, Single acting spring return, Fixing type: Female thread at both ends, Male thread on piston rod, 63mm bore, 100mm stroke, with magnet, Model: SQASB 63 x 100 - SM

### Specifications

Bore size(mm)	12	16	20	25	32	40	50	63	80	100
Acting type	Double Acting; Single acting: with spring return/with spring extend									
Working medium	Clean Air (25 μ filtration)									
working pressure (Bar)	1-10									
Max.working pressure (Bar)	15									
Working temperature ( )	5-60									
Piston rod thread type	Female thread (Standard), Male thread (Optional)									
Cushion	None									
Tolerance of stroke	+1.0/0									
Lubrication	Not required									
Installation (On barrel ends)	Through hole (standard), Female thread on both sides (Optional)									
Port Size	M5x0.8		G1/8		G1/4		G3/8			

### Main dimensions

Model	Note1)Stroke Range	B	D	E	F	H	C	I	J	K	L	M	N	O	P	Q	W	Z
SQ12-	5-30	17	6	25	5	M3x0.5	6	32	-	5	3.5	15.5	3.5	6.5	Depth 3.5	M5x0.8	7.5	-
SQ18-	5-30	18.5	8	29	5.5	M4x0.7	8	38	-	6	3.5	20	3.5	6.5	Depth 3.5	M5x0.8	8	10
SQ20-	5-50	19.5	10	36	5.5	M5x0.8	7	47	-	8	4.5	25.5	5.5	9	Depth 7	M5x0.8	9	10
SQ25-	5-50	22.5	12	40	5.5	M6x1.0	12	52	-	10	5	28	5.5	9	Depth 7	M5x0.8	11	10
SQ32-	5	23	16	45	5.5	M8x1.25	13	60	4.5	14	7	34	5.5	9	Depth 7	M5x0.8	11.5	14
SQ40-	5-50	29.5	16	52	8	M8x1.25	13	69	5	14	7	40	5.5	9	Depth 7	1/8	11	57
SQ50-	10-50	30.5	20	64	10.5	M10x1.5	15	86	7	17	8	50	6.6	11	Depth 8	1/4	10.5	71
SQ63-	10-50	36	20	77	10.5	M10x1.5	15	103	7	17	8	60	9	14	Depth 10.5	1/4	15	84
SQ80-	10-50	43.5	25	98	12.5	M16x2.0	21	132	6	22	10	77	11	17	Depth 13.5	3/8	16	104
SQ100-	10-50	53	30	117	13	M20x2.5	27	156	6.5	27	12	94	11	17	Depth 13.5	3/8	23	123.5

### Basic through hole type: SQ

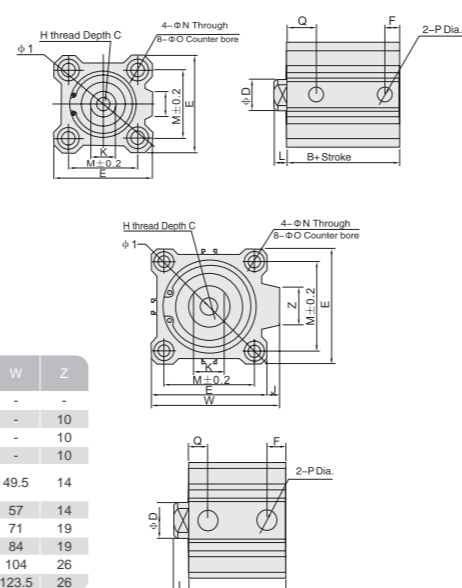

## SQ-Z Series Compact Cylinder

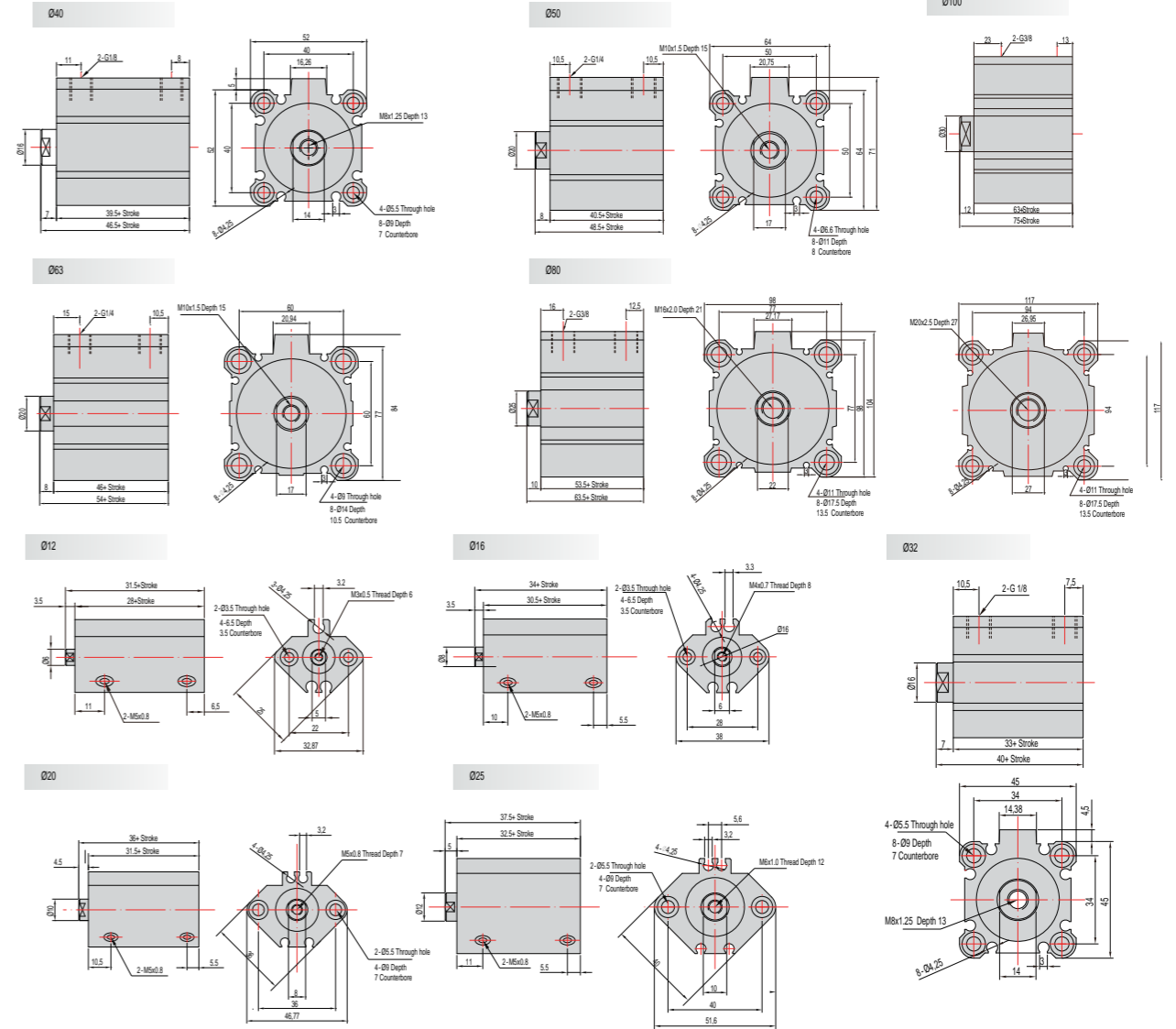

## EXS Series Double-shaft Cylinder

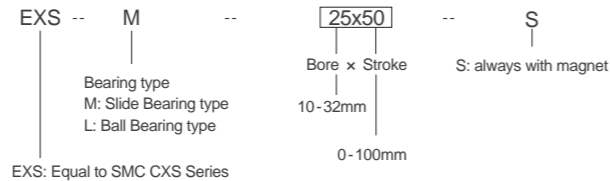

### How to Order?

#### Order Example:

EXS Series, Slide Bearing type, 10mm bore, 30mm stroke, Model: EXSM 10 x 30 - S  
EXS Series, Ball Bearing type, 15mm bore, 35mm stroke, Model: EXSL 15 x 35 - S

### Specifications

Bore size(mm)	10	15	20	25	32	
Acting type	Double Acting					
Working medium	Clean Air (25 μ filtration)					
Max.working pressure (Bar)	7					
Min.working pressure (Bar)	1			0.5		
Guaranteed pressure (Bar)	10.5					
Working temperature (°C)	5~60					
Cushion type	Both ends cushion					
Structure	Double Power					
Lubrication	Not required					
Adjustable cushion	Return Stroke 0~-5mm					
Bearing	Slide Bearing type & Ball bushing Bearing type					
Non-rotating accuracy	Slide bearing	+0.15	+0.13	+0.11	+0.1	+0.08
	Ball bushing bearing	+0.1	+0.07	+0.06	+0.05	+0.04
Port Size	M5x0.8					

### Main dimensions

Model	Stroke	10+1/2 stroke	13+stroke	45+stroke	58.5+stroke
EXS 6-10	10	15	23	55	68.5
EXS 6-20	20	20	33	65	78.5
EXS 6-30	30	25	43	75	88.5
EXS 6-40	40	30	53	85	98.5
EXS 6-50	50	35	63	95	108.5

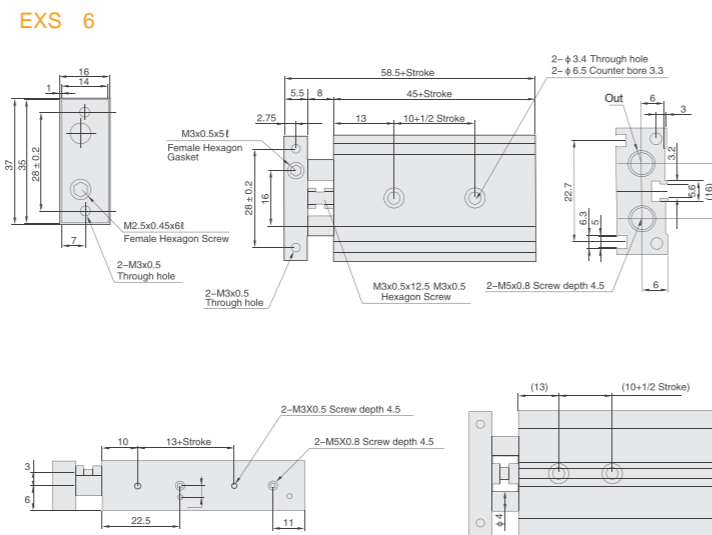

## EXS Series Double-shaft Cylinder

EXS 10, 15, 20, 25, 32

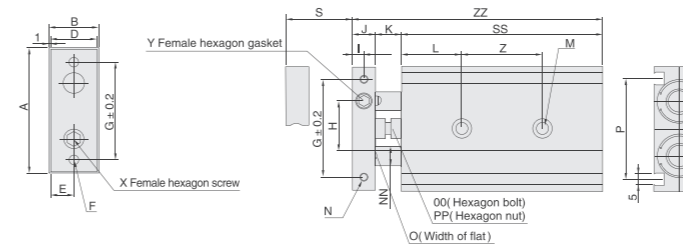

10-15

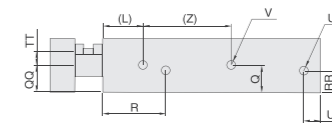

20-32

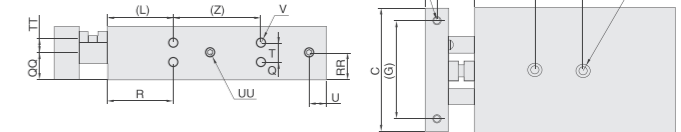

### Main dimensions

Model	A	B	C	D	E	F	G	H	I	J	K	L	M	N	NN	O	OO	P	PP	Q	QQ	RR	S	SS	T	TT	U	UU	V	W	X	Y	Z	ZZ				
EXS 10-10																							10	65										30	82			
EXS 10-20																							20	75										30	90			
EXS 10-30	46	17	44	15	7.5	2-M4 x 0.7 Through hole	35	20	4	8	9	20	2-M4 x 0.7 Through hole 2- 6.5 concave pit 3.3	2-M3 x 0.5 Screw depth 5	6	5	M4 x 0.7 x 14.5L	33.6	M4 x 0.7	8.5	7	30	7	30	85	-	5	8	4-M5 x 0.8 Screw depth 4.5	4-M3 x 0.5 Screw depth 4.5	2-M4 x 0.7 Screw depth 7	M3 x 0.5 x 10L	M3 x 0.5 x 5L	40	102			
EXS 10-40																							40	95										40	112			
EXS 10-50																							50	105											40	122		
EXS 15-10																							10	70											25	89		
EXS 15-20																							20	80												25	99	
EXS 15-30	58	20	56	18	9	2-M5 x 0.8 Through hole	45	25	5	10	9	30	2-M4 x 0.7 Through hole 2- 8 concave pit 4.4	2-M4 x 0.7 Screw depth 5	8	6	M4 x 0.7 x 14.5L	48	M4 x 0.7	10	10	38.5	10	30	90	-	5	8	4-M5 x 0.8 Screw depth 4.5	4-M4 x 0.7 Screw depth 5	2-M5 x 0.8 Screw depth 8	M5 x 0.8 x 10L	M4 x 0.7 x 4L	35	109			
EXS 15-40																							40	100											35	119		
EXS 15-50																							50	110											35	129		
EXS 20-10																							10	80											30	104		
EXS 20-20																							20	90												30	114	
EXS 20-30																							30	100												40	124	
EXS 20-40	64	25	62	23	11.5	2-M5 x 0.8 Through hole	50	28	6	12	12	30	2-M4 x 0.7 Through hole 2- 9.5 concave pit 5.3	2-M4 x 0.7 Screw depth 5	10	8	M6 x 1.0 x 18.5L	53	M6 x 1.0	7.75	12.5	45	7.75	40	110	9.5	6.5	8	4-M5 x 0.8 Screw depth 4.5	8-M4 x 0.7 Screw depth 6	2-M6 x 1.0 Screw depth 10	M6 x 1.0 x 12L	M5 x 0.7 x 5L	40	134			
EXS 20-50																							50	120												40	144	
EXS 20-75																							75	145												60	169	
EXS 20-100																							100	170												60	194	
EXS 25-10																							10	82													30	106
EXS 25-20																							30	92													30	116
EXS 25-30																							30	102													40	126
EXS 25-40	80	30	78	28	14	2-M6 x 1.0 Through hole	60	35	6	12	12	30	2-M5 x 0.8 Through hole 2- 11 concave pit 6.3	2-M5 x 0.8 Screw depth 5	12	10	M6 x 1.0 x 18.5L	64	M6 x 1.0	8.5	15	46	15	40	112											40	136	
EXS 25-50																							50	122													40	146
EXS 25-75																							75	147													60	171
EXS 25-100																							100	172													60	196
EXS 32-10																							10	92													40	122
EXS 32-20																							20	102													40	132
EXS 32-30																							30	112													50	142
EXS 32-40	98	38	96	36	18	2-M6 x 1.0 Through hole	75	44	8	16	14	30	2-M5 x 0.8 Through hole 2- 11 concave pit 6.3	2-M5 x 0.8 Screw depth 5	16	13	M8 x 1.25 x 23L	76	M8 x 1.25	9	19	56	19	40	122	20	11.5	10	4-1/8 Screw depth 6.5	8-M5 x 0.8 Screw depth 7.5	2-M8 x 1.25 Screw depth 12	M8 x 1.25 x 14L	M8 x 1.25 x 5L	50	152			
EXS 32-50																							50	132													50	162
EXS 32-75																							75	157													70	187
EXS 32-100																							100	182													70	212



## SG Series Three-shaft Cylinder

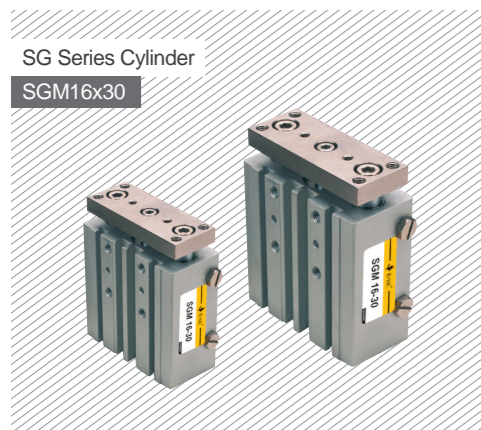

SG Series Cylinder  
SGM16x30

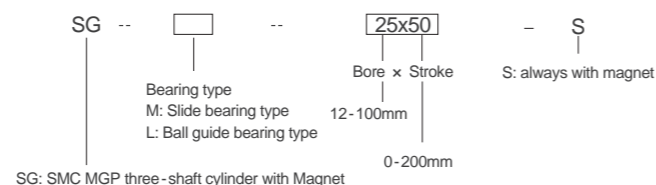

### How to Order?

#### Order Example:

SG type three - shaft cylinder,slide bearing type,20mm bore,60mm stroke,Model:SGM 20x60 - S  
SG type three - shaft cylinder,ball bearing type,20mm bore,75mm stroke,with magnet, Model:SGB 32x75 - S

### Specifications

Bore size(mm)	12	16	20	25	32	40	50	63	80	100
Guaranteed pressure (Bar)	15									
Working pressure (Bar)	1.2~10.2									
Working temperature ( )	-10~60									
Piston speed (mm/s)	50~500					50~400				
Cushion type	Rubber cushion									
Stroke tolerance	+1.5/0									
Bearing	Slide bearing/ Ball guide bearing									
Non - rotating accuracy	Slide bearing	± 0.08 °	± 0.07 °	± 0.06 °	± 0.05 °	± 0.04 °				
	Ball bushing	± 0.10 °	± 0.09 °	± 0.06 °	± 0.06 °	± 0.05 °				
Port Size	M5x0.8			G1/8			G1/4			G3/8

## SG Series Three-shaft Cylinder

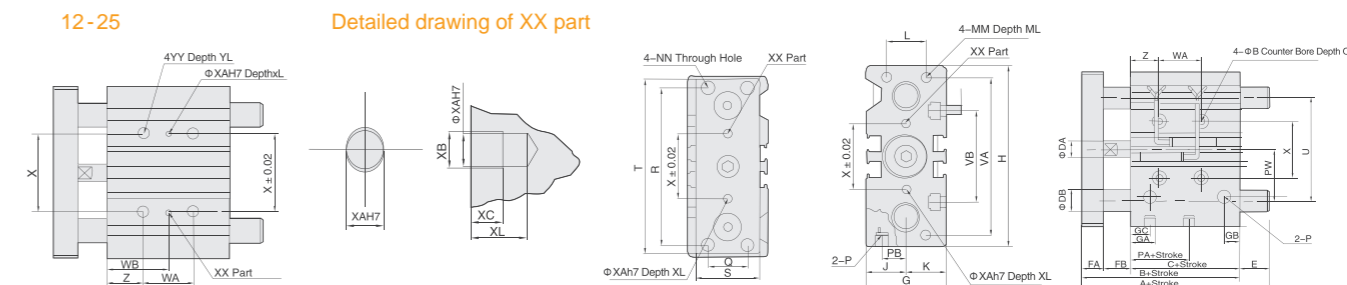

### Main dimensions

Bore size(mm)	Standard stroke	B	C	DA	FA	FB	G	GA	GB	H	HA	J	K	L	MM	ML	NN	OA	OB	OL	HA	P	PA	PB	PW	Q
12	10,20,30,40,50,75,100	42	29	6	8	5	26	11	7.5	58	M4	13	13	18	M4 × 0.7	10	M4 × 0.7	4.3	8	4.5	M4	M5 × 0.8	13	8	18	14
16	10,20,30,40,50,75,100	46	33	8	8	5	30	11	8	64	M4	15	15	22	M5 × 0.8	12	M5 × 0.8	4.3	8	4.5	M4	M5 × 0.8	15	10	19	16
20	20,30,40,50,75,100,125,150,175,200	53	37	10	10	6	36	10.5	8.5	83	M5	18	18	24	M5 × 0.8	13	M5 × 0.8	5.6	9.5	5.5	M5	Rc1/8	12.5	10.5	25	18
25	20,30,40,50,75,100,125,150,175,200	53.5	37.5	12	10	6	42	11.5	9	93	M5	21	21	30	M6 × 1.0	15	M6 × 1.0	5.6	9.5	5.5	M5	Rc1/8	12.5	13.5	28.5	26

Bore size(mm)	Standard stroke	R	S	T	U	VA	VB	WA			WB			X	XA	XB	XC	XL	YY	YL	Z
								30st	30st-100st	125st	30st	30st-100st	125st								
12	10,20,30,40,50,75,100	48	22	56	41	50	37	20	40	-	15	25	-	23	3	3.5	3	6	M5 × 0.8	10	5
16	10,20,30,40,50,75,100	54	25	62	46	56	38	24	44	-	17	27	-	24	3	3.5	3	6	M5 × 0.8	10	5
20	20,30,40,50,75,100,125,150,175,200	70	30	81	54	72	44	24	44	120	29	39	77	28	3	3.5	3	6	M5 × 1.0	12	17
25	20,30,40,50,75,100,125,150,175,200	78	38	91	64	82	50	24	44	120	29	39	77	34	4	4.5	3	6	M5 × 1.0	12	17

### SGM slide bearing

Bore size(mm)	A			DB	E		
	50st	50st < 100st	100st <		50st	50st < 100st	100st <
12	42	60.5	85	8	0	18.5	43
16	46	64.5	95	10	0	18.5	49
20	53	84.5	122	16	0	31.5	69
25	53.5	85	122	20	0	31.5	68.5

### SGB ball guide bearing

Bore size(mm)	A			DB	E		
	50st	50st < 100st	100st <		50st	50st < 100st	100st <
12	43	55	85	6	1	13	43
16	49	65	95	8	3	19	49
20	63	80	104	10	10	27	51
25	69.5	80.5	104.5	13	16	32	51

### SG Series Three-shaft Cylinder

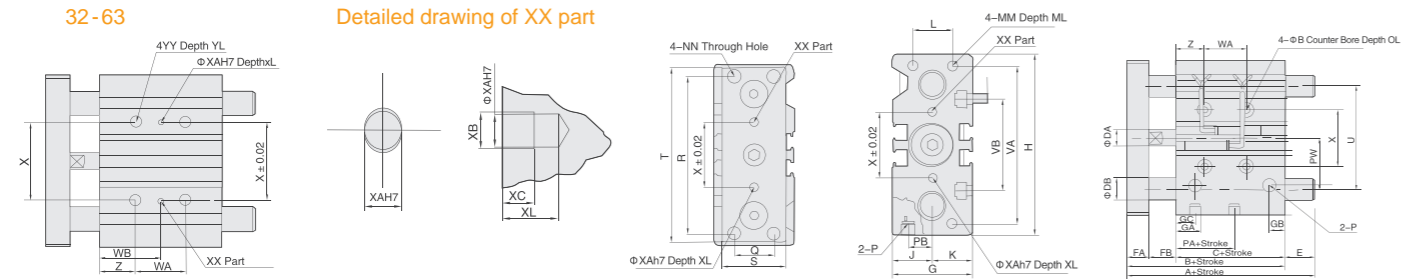

#### Main dimensions

Bore size(mm)	Standard stroke	B	C	DA	FA	FB	G	GA	GB	GC	H	HA	J	K	L	MM	ML	NN	OA	OB	OL	HA	P	PA	PB	PW	Q
32	25,50,75, 100,125,150, 175,200	59.5	37.5	16	12	10	48	12.5	9	12.5	112	M6	24	24	34	M8 x 1.25	20	M8 x 1.25	6.6	11	7.5	Rc1/8	7	15	15	34	30
40		66	44	16	12	10	54	14	10	14	120	M6	27	27	40	M8 x 1.25	20	M8 x 1.25	6.6	11	7.5	Rc1/8	13	18	18	38	30
60		72	44	20	16	12	64	12	11	14	148	M8	32	32	46	M10 x 1.5	22	M10 x 1.5	8.6	14	9	Rc1/4	9	21.5	21.5	47	40
63		77	49	20	16	12	78	16.5	13.5	16.5	162	M10	39	39	58	M10 x 1.5	22	M10 x 1.5	8.6	14	9	Rc1/4	14	28	28	55	50

Bore size(mm)	Standard stroke	R	S	T	U	VA	VB	WA			WB			X	XA	XB	XC	XL	YY	YL	Z
								30st	30st-100st	125st	30st	30st-100st	125st								
32	25,50,75, 100,125,150, 175,200	96	44	110	78	98	63	24	48	124	33	45	83	42	4	4.5	3	6	M8 x 1.25	16	21
40		104	44	118	86	106	72	24	48	124	34	46	84	50	4	4.5	3	6	M8 x 1.25	16	22
60		130	60	146	110	130	92	24	48	124	36	48	86	66	5	6	4	8	M10 x 1.5	20	24
63		130	70	158	124	142	110	28	52	128	38	50	88	80	5	6	4	8	M10 x 1.5	20	24

#### SGM slide bearing

Bore size(mm)	A			DB	E		
	50st	50st < 200st	200st <		50st	50st < 200st	200st <
32	97	102	140	20	37.5	42.5	80.5
40	97	102	140	20	31	36	74
50	106.5	118	161	25	34.5	46	89
63	106.5	118	161	25	29.5	41	84

#### SGB roller guide bearing

Bore size(mm)	A				DB	E			
	50st	50st < 100st	50st < 200st	200st <		50st	50st < 100st	50st < 200st	200st <
32	81	98	118	140	16	21.5	38.5	58.5	80.5
40	81	98	118	140	16	15	32	52	74
50	93	114	134	161	20	21	42	62	89
63	93	114	134	161	20	16	37	57	84

### SG Series Three-shaft Cylinder

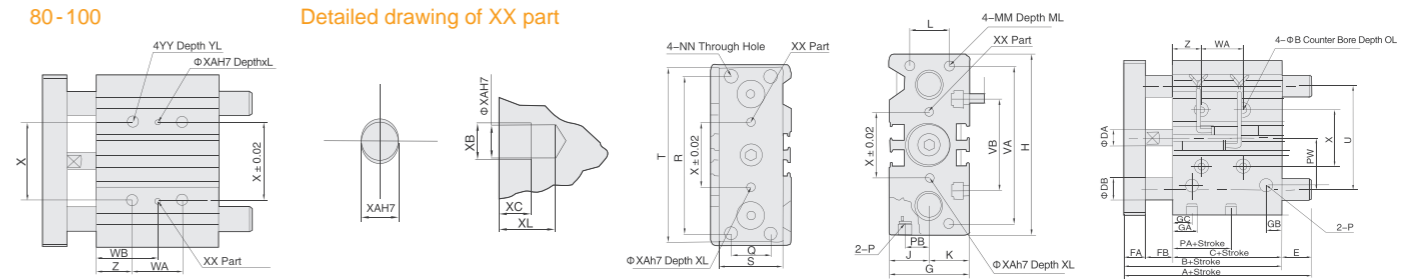

#### Main dimensions

Bore size(mm)	Standard stroke	B	C	DA	FA	FB	G	GA	GB	GC	H	HA	J	JA	JB	K	L	MM	ML	NN	OA	OB	OL	P	PA	PB	PW
80	25,50,75,100, 125,150,175,200	96.5	56.5	25	22	18	91.5	19	15.5	14.5	202	M12	45.5	38	7.5	46	54	M12 x 1.75	25	M12 x 1.75	10.6	17.5	8	Rc3/8	14.5	25.5	74
100		116	66	30	25	25	111.5	23	19	18	240	M14	55.5	45	10.5	56	62	M14 x 2.0	31	M14 x 2.0	12.5	20	8	Rc3/8	17.5	32.5	89

Bore size(mm)	Standard stroke	Q	R	S	T	U	VA	VB	WA			WB			X	XA	XB	XC	XL	YY	YL	Z
									25st	50, 75, 100st	≥100st	25st	50, 75, 100st	≥100st								
80	25,50,75,100, 125,150,175,200	52	174	75	198	156	180	140	28	52	128	42	54	92	100	6	7	5	10	M12 x 1.75	24	28
100		64	210	90	236	188	210	166	48	72	148	35	47	85	124	6	7	5	10	M14 x 2.0	28	11

#### SGM slide bearing

Bore size(mm)	A			DB	E		
	50st	50st < 200st	200st <		50st	50st < 200st	200st <
80	115	142	193	30	18.5	45.5	96.5
100	137	162	203	36	21	46	87

#### SGB roller guide bearing

Bore size(mm)	A				DB	E			
	30st	30st < 100st	50st < 200st	200st <		30st	30st < 100st	50st < 200st	200st <
80	109.5	130	160	193	25	13	33.5	63.5	96.5
100	121	147	180	203	30	5	31	64	87

## SHZ2/SHC2 Style Air Gripper

SHZ2/SHC2 Series Cylinder

SHZ2-32D  
SHC2-32D



SHZ -- 2 -- 32 -- D -- S

Finger quantity: 2pcs  
Bore: SHZ: 10-40, SHC: 10-25  
Acting type: D: Double acting, S: Single acting (N.O.), C: Single acting (N.C.)  
Dusty Seal Material: Blank: CR, F: FKM, S: Si

SHZ: Equal to SMC MHZ Parallel type gripper  
SHC: Equal to SMC MHC Point type gripper

### How to Order?

Order Example:  
SHZ Series parallel type gripper, double acting, 20mm bore, model: SHZ2-20D  
SHC Series point type gripper, single acting, N.O., 16mm bore, model: SHC2-16S

### Specifications

Bore size(mm)	6	10	16	20	25	32	40
Acting type	Double Acting; Single acting: normal open/normal close						
Working medium	Clean Air (25 μ filtration)						
Min. working pressure (Bar)	Double Acting	1.5	2				1
	Single acting	3	3.5				2.5
Working pressure (Bar)	7						
Working temperature ( )	-20~70						
Max. acting frequency	180(C.P.M)			60(C.P.M)			
Magnet	always have						
Lubrication	Not required						
Port Size	M3x0.5			M5x0.8			

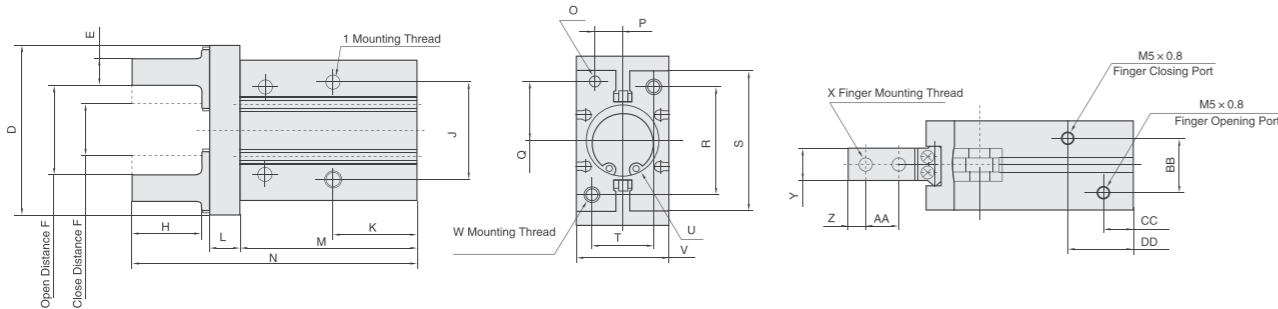
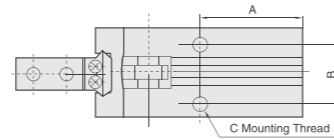

## SHZ2/SHC2 Style Air Gripper

SHA2 10~25  
Φ10mm Bore

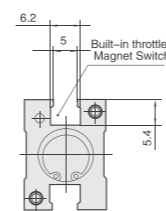

Built-in throttle's Magnet Switch

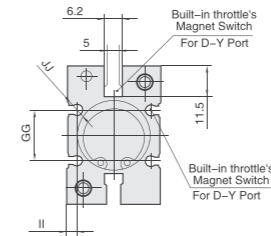

Finger Position/Narrow Type

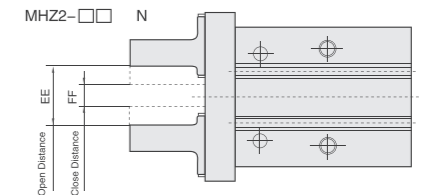

### Main dimensions

Bore	A	B	C	D	E	F	G	H	I	J	K	L	M	N	O	P	Q	R	S	T
10	27	11.4	M3 x 0.5 Depth 6	29	4 <sup>0</sup> <sub>-0.1</sub>	15.2 <sup>+0.2</sup> <sub>0</sub>	11.2 <sup>0</sup> <sub>-0.7</sub>	12	M3 x 0.5 Depth 5.5	16	23	6	37.8	57	2H9 <sup>+0.025</sup> <sub>0</sub> Depth3	5.2 ± 0.02	7.6 ± 0.02	18	23	12
16	30	16	M4 x 0.7 Depth 4.5	38	5 <sup>0</sup> <sub>-0.1</sub>	20.9 <sup>+0.2</sup> <sub>0</sub>	14.9 <sup>0</sup> <sub>-0.7</sub>	15	M4 x 0.7 Depth 8	24	24.5	7.5	42.5	67.3	3H9 <sup>+0.025</sup> <sub>0</sub> Depth3	6.5 ± 0.02	11 ± 0.02	22	30.6	15
20	35	18.6	M5 x 0.8 Depth 8	50	8 <sup>0</sup> <sub>-0.1</sub>	26.3 <sup>+0.2</sup> <sub>0</sub>	16.3 <sup>0</sup> <sub>-0.7</sub>	20	M5 x 0.8 Depth 10	30	29	9.5	52.8	84.8	4H9 <sup>+0.030</sup> <sub>0</sub> Depth3	7.5 ± 0.02	16.8 ± 0.02	32	42	18
25	36.5	22	M6 x 1 Depth 10	63	10 <sup>0</sup> <sub>-0.1</sub>	33.3 <sup>+0.2</sup> <sub>0</sub>	19.3 <sup>0</sup> <sub>-0.8</sub>	25	M6 x 1 Depth 12	36	30	11	63.6	102.7	4H9 <sup>+0.030</sup> <sub>0</sub> Depth4	10 ± 0.02	21.8 ± 0.02	40	52	22

  

Bore	U	V	W	X	Y	Z	AA	BB	CC	DD	EE	FF	GG	HH	II	JJ
10	11H9 <sup>+0.043</sup> <sub>0</sub> Depth2	16.4 ± 0.05	M3 x 0.5 Depth 6	M2.5 x 0.45	5 <sup>0</sup> <sub>-0.05</sub>	3	5.7	11	9	19	9.7 <sup>+0.2</sup> <sub>0</sub>	5.7 <sup>0</sup> <sub>-0.4</sub>	-	5.4	-	-
16	17H9 <sup>+0.043</sup> <sub>0</sub> Depth2	23.6 ± 0.05	M4 x 0.7 Depth 4.5	M3 x 0.5	8 <sup>0</sup> <sub>-0.05</sub>	4	7	13	7.5	19	12.6 <sup>+0.2</sup> <sub>0</sub>	6.6 <sup>0</sup> <sub>-0.4</sub>	11.6	5.8	2.1	4
20	21H9 <sup>+0.052</sup> <sub>0</sub> Depth3	27.6 ± 0.05	M5 x 0.8 Depth 8	M4 x 0.7	10 <sup>0</sup> <sub>-0.05</sub>	5	9	15	10	23	17.2 <sup>+0.2</sup> <sub>0</sub>	7.2 <sup>0</sup> <sub>-0.4</sub>	14	9	2.1	4
25	26H9 <sup>+0.062</sup> <sub>0</sub> Depth3.5	33.6 ± 0.05	M6 x 1 Depth 10	M5 x 0.8	12 <sup>0</sup> <sub>-0.05</sub>	6	12	20	10.7	23.5	22.8 <sup>+0.2</sup> <sub>0</sub>	8.8 <sup>0</sup> <sub>-0.4</sub>	19	11.5	3.5	4

SHA2 32

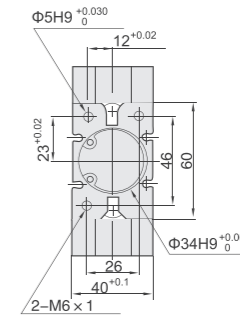
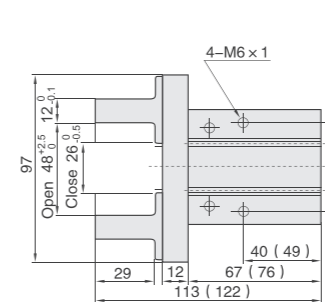
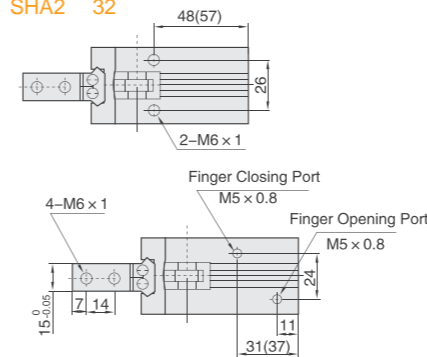

Built-in throttle's Magnet Switch

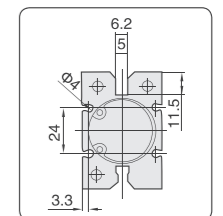

## SHZ2/SHC2 Style Air Gripper

SHA2 40

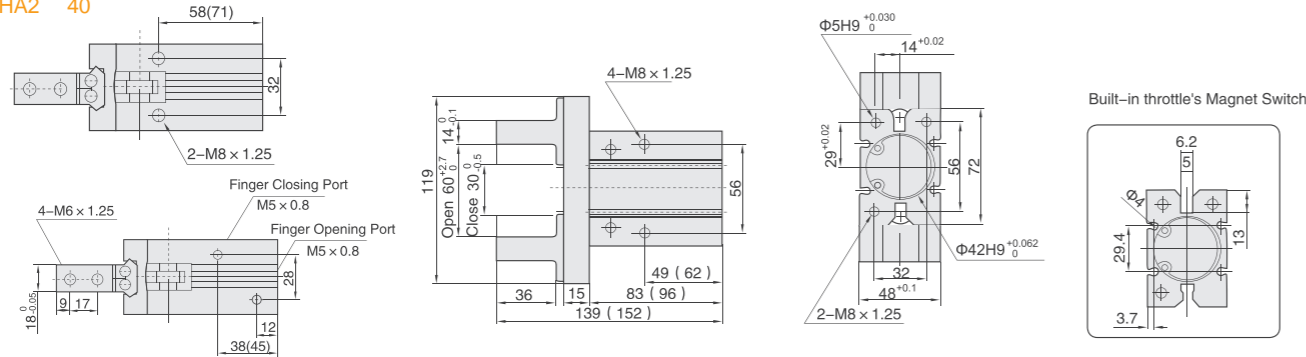

SHC2 10~25

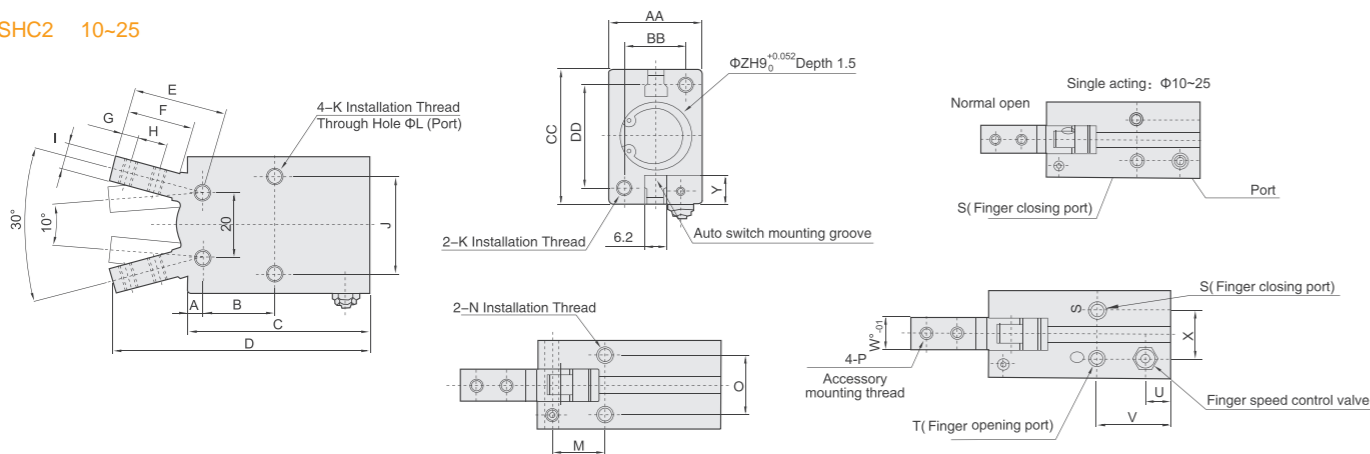

Bore	Port size										Port size																				
	A	B	C	D	E	F	G	H	I	J	K	L	M	N	O	P	Q	R	S	T	U	V	W	X	Y	Z	AA	BB	CC	DD	
10	2.8	12.8	38.6	52.4	17.2	12	3	5.7	4	16	M3 x 0.5	Depth 5	2.6	8.8	M3 x 0.5	Depth 6	11.4	M2.5 x 0.45	3	5.7	M3 x 0.5	7.2	18.8	6.4	10.4	5.4	11	16.4	12	23	18
16	3.9	16.2	44.6	62.5	22.6	16	4	7	7	24	M4 x 0.7	Depth 8	3.4	10.7	M4 x 0.7	Depth 8	16	M3 x 0.5	4	7	M5 x 0.8	7	18.3	8	13	5.8	17	23.6	15	30.6	22
20	4.5	21.7	55.2	78.7	28	20	5.2	9	8	30	M5 x 0.8	Depth 10	4.3	15.7	M5 x 0.8	Depth 8	18.6	M4 x 0.7	5	9	M5 x 0.8	7.5	22.2	10	15	9	21	27.6	18	42	32
25	4.6	25.8	60.2	92	37.5	27	8	12	10	36	M6	Depth 12	5.1	19.3	M6	Depth 10	22	M5 x 0.8	6	12	M5 x 0.8	7.7	23.5	12	20	11.5	26	33.6	22	52	40

## SHT2 Series Angle Style Air Gripper

SHT2 Series Cylinder

SHT2-32DS

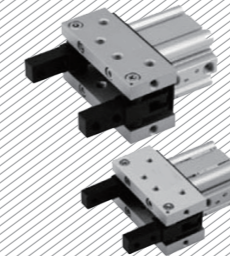

### How to Order?

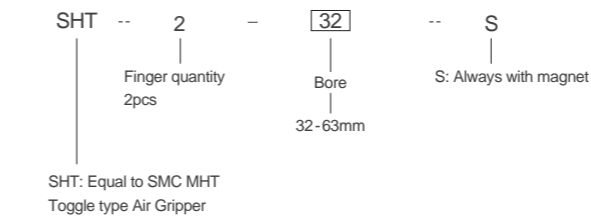

### Order Example:

Toggle type air gripper, finger quantity 2pcs, 40mm, Model: SHT2-40S  
Toggle type air gripper, finger quantity 2pcs 63mm, Model: SHT2-63S

### Specifications

Bore size(mm)	32	40	50	63
Acting type	Double Acting			
Working medium	Clean Air (25 μ filtration)			
Working pressure (Bar)	1~6			
Working temperature ( )	5~60			
Finger open/close angel	-3~28 °	-3~27 °	-2~23 °	-2~23 °
Weight(kg)	0.80	1.09	1.93	2.80
Effective gripping force	12.4	36.0	63.0	106
Lubrication	Not required			

## SHL2 Series Parallel Air Gripper

SHL2 Series Air Gripper

SHL2-10DS



### How to Order?

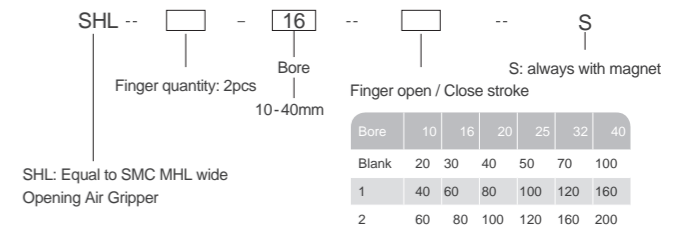

### Order Example:

SHL2 Series, bore 16mm, stroke 30mm, Model: SHL2-16S  
SHL2 Series, bore 25mm, stroke 120mm, Model: SHL2-25-2S

### Specifications

Bore size(mm)	10	16	20	25	32	40
Acting type	Double Acting					
Working medium	Clean Air (25 μ filtration)					
Min. working pressure (Bar)	1.5			1.0		
Guaranteed pressure (Bar)	6					
Working temperature ( )	-10~60					
Repeatability(mm)	± 0.1					
Effective gripping force(N) at 5 Bar	14	45	74	131	228	396
Port Size	M5x0.8			G1/8		

## SJ Series Stainless Cylinder

SJ Series Cylinder

SJ16x75  
SJSA 6x20



### How to Order?

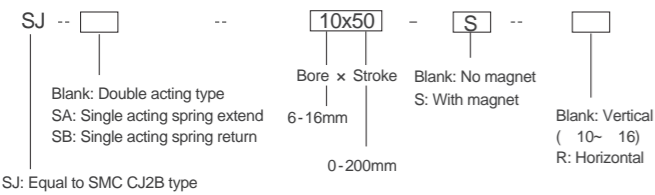

### Order Example:

SJ type mini cylinder, basic type, 12mm bore, 60mm stroke, Model: SJ12 x 60  
SJ type mini cylinder, Single acting spring extend type, 10mm bore, 25mm stroke, with magnet, Model: SJSA10 x 25 -S

### Specifications

Bore size(mm)	6	10	16
Guaranteed pressure (Bar)	10.5		
Max.working pressure(Bar)	7		
Min.working pressure(Bar)	1.2	0.6	
Working temperature ( )	-10~70		
Speed range (mm/s)	50~750		
Cushion type	Both Ends Cushion		
Tolerance of stroke	+1.0/0		

## SM Series Stainless Steel Cylinder

SM Series Cylinder

SM25x100  
SM40x40-S



### How to Order?

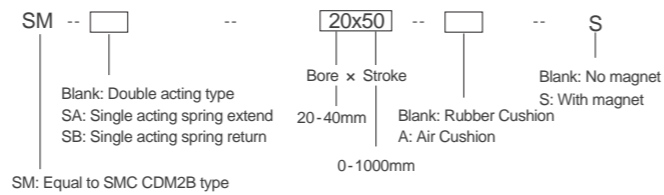

### Order Example:

SM type mini cylinder, basic type, 16mm bore, 60mm stroke, with magnet, Model: SM12 x 60 -S  
SM type mini cylinder, Single acting spring extend type, 10mm bore, 25mm stroke, with magnet, Model: SMSA10 x 25 -S

### Specifications

Bore size(mm)	20	25	32	40
Acting type	Double Acting/Single Acting			
Working medium	Clean Air (25 μ filtration)			
Working pressure (Bar)	0.5~10(double acting);1.8~10(single acting spring return); 2.3~10(single acting spring extend);			
Working temperature ( )	-10~70			
Speed range (mm/s)	Min.:10			Max.: 1000
Tolerance of stroke	+1.4/0			

## EAB Series Slim Type Cylinder

EAB Series Cylinder

EAB20x75

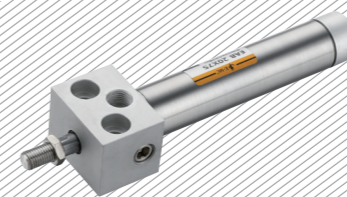

### How to Order?

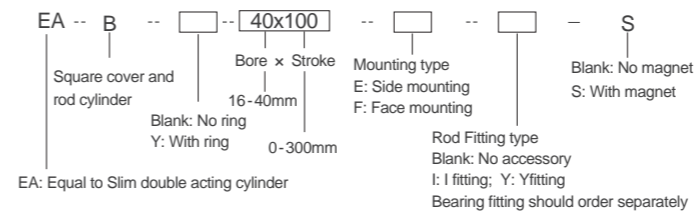

### Order Example:

EAB series slim type with square cover and rod cylinder, 25mm bore, 100 stroke, side mounting, Model: EAB25x100 -E

### Specifications

Bore size(mm)	16	20	25	32	40
Acting type	Double Acting				
Working medium	Clean Air (25 μ filtration)				
Mounting type	Foot type Flange type Single U- ring type				
Working pressure (Bar)	9				
Guaranteed pressure (Bar)	13				
Working temperature ( )	0~70				
Speed range (mm/s)	30~700				
Cushion type	Fixed (Rubber Cushion)				
Lubrication	Not required				
Port size	1/8				

## SP Series Needle Cylinder

SP Series Cylinder

SP25x100

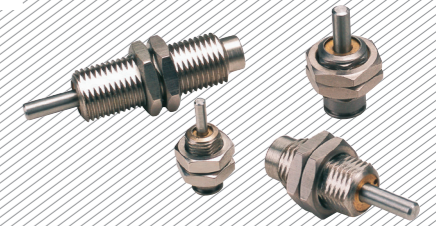

### How to Order?

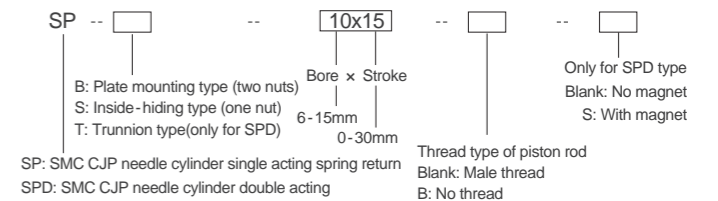

### Order Example:

SP type needle cylinder, single acting spring return, plate mounting, male thread, 6mm bore, 10mm stroke, Model: SPB 6 x 10  
SP type needle cylinder, double acting, Inside-hiding mounting, with magnet, no thread 10mm bore, 25mm stroke, Model: SPDS 10 x 25 -BS

### Specifications

Bore size(mm)	6	10	15
Acting type	Double Acting; Single acting spring return		
Working medium	Clean Air (25 μ filtration)		
Guaranteed pressure (Bar)	10.5		
Max.working pressure (Bar)	7		
Min.working pressure	SP 2	1.5	
	SPD 1.2	0.6	
Working temperature ( )	5~60		
Cushion type	None (SP), both ends cushion (SPD)		
Stroke tolerance	+1.0/0		
Lubrication	Not required		
Port size	M5x0.8		

## EU Series Free Installation Cylinder

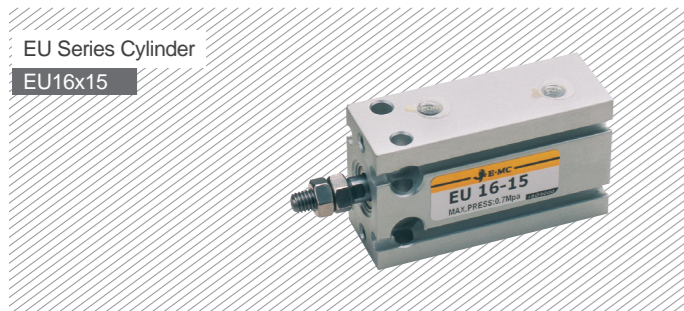

### How to Order?

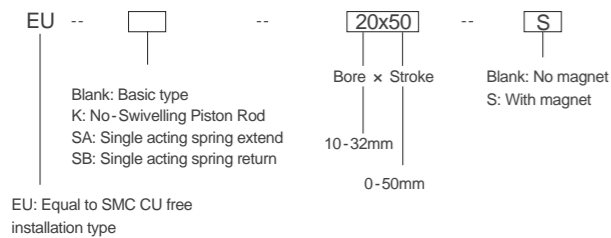

### Order Example:

EU type free installation cylinder, basic type, 20mm bore, 50mm stroke, Model: EU20 x 50  
EU type free installation cylinder, Single acting spring return type, 25mm bore, 60mm stroke, with magnet, Model: EUSB25 x 60-S

### Specifications

Bore size(mm)	10	16	20	25	32
Acting type	Double Acting; Single acting: with spring return/with spring extend				
Guaranteed pressure (Bar)	10				
Working pressure (Bar)	7				
Working temperature ( )	5-60				
Cushion type	Rubber cushion				
Port Size	M5x0.8			G1/8	

## EN Series Double-shaft Cylinder



### How to Order?

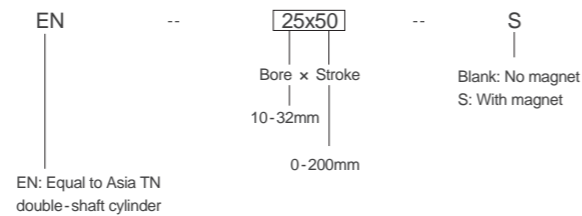

### Order Example:

EN type double-shaft cylinder, basic type, 20mm bore, 50mm stroke, Model: EN 20 x 50  
EN type double-shaft cylinder, 25mm bore, 50mm stroke, with magnet, Model: EN 25 x 50-S

### Specifications

Bore size(mm)	10	16	20	25	32
Acting type	Double Acting				
Working medium	Clean Air (25 μ filtration)				
working pressure (Bar)	1-9				
Guaranteed pressure (Bar)	13.5				
Working temperature ( )	-5-70				
Speed range (mm/s)	100-500				
Adjusting stroke (mm)	-10-0				
Cushion type	Adjustable cushion				
Non-rotating accuracy	0.4 °			0.3 °	
Port Size	M5x0.8			G1/8	

## SR Series Cylinder

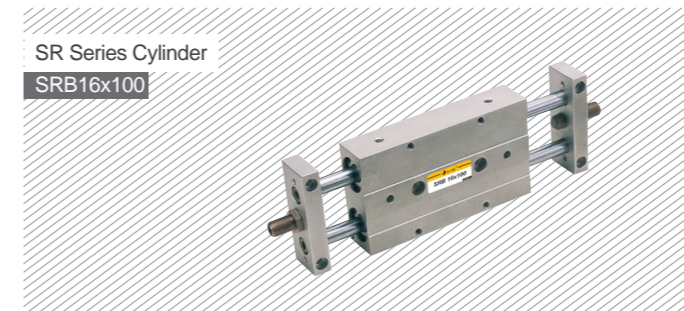

### How to Order?

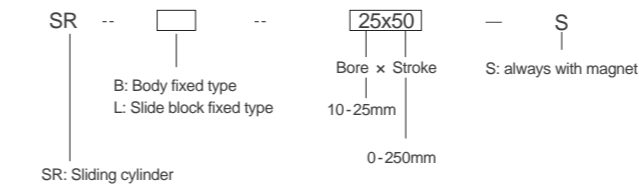

### Order Example:

SR type sliding cylinder, body fixed type, 20mm bore, 50mm stroke, Model: SRB 20 x 50-S  
SR type sliding cylinder, Slide block fixed type, 16mm bore, 75mm stroke, Model: SRL 16 x 75-S

### Specifications

Bore size(mm)	10	16	20	25
Acting type	Double piston Double Acting			
Working medium	Clean Air (25 μ filtration)			
Working temperature ( )	-5-70			
Working pressure (Bar)	1-9			
Guaranteed pressure (Bar)	13.5			
Speed range (mm/s)	50-200			
Cushion type	No	Shock Absorber		
Oil supply	Not required			
Non-rotating accuracy	+0.1 °		+0.5 °	
Port Size	M5x0.8		G1/8	

## EMQ Series Cylinder

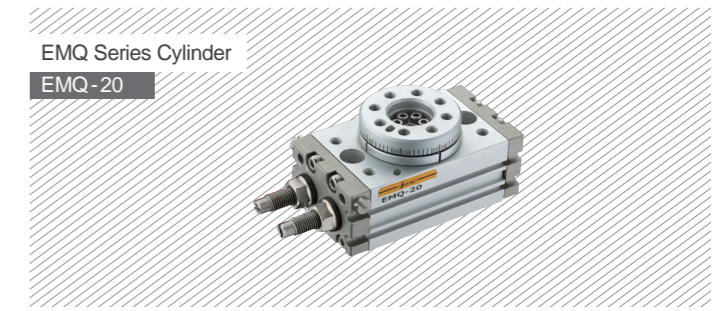

### How to Order?

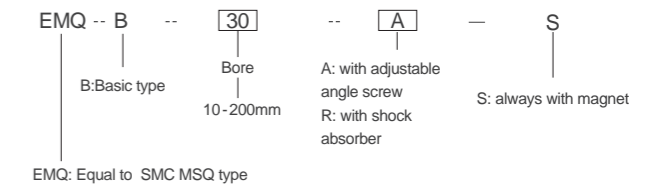

### Order Example:

EMQ Series Rotary cylinder, bore 10mm, with adjustable angle screw, Model: EMQB10A-S  
EMQ Series Rotary Cylinder, bore 30mm, with shock absorber, Model: EMQB30R-S

### Specifications

Bore size(mm)	10	20	30	50	70	100	200
Acting type	Double Acting						
Working medium	Clean Air (25 μ filtration)						
Max.working pressure (Bar)	10						
Min.working pressure (Bar)	6						
Working temperature ( )	0-60						
Cushion type	Rubber cushion(standard)/ shock absorber(optional)						
Allowed Power	With adjustable angle screw	0.007J	0.025J	0.048J	0.081J	0.24J	0.32J
	With shock absorber	0.039J	0.116J	0.294J	1.1J	1.6J	2.9J
Angle adjustable Range	0~190 °						
Max. Rotation Angle	190 °						
Piston Diameter	15	18	21	25	28	32	40
Port Size	M5 x 0.8			G1/8			

## ERQ Series Stopper Cylinder

ERQ Series Cylinder  
ERQA60x75R



### How to Order?

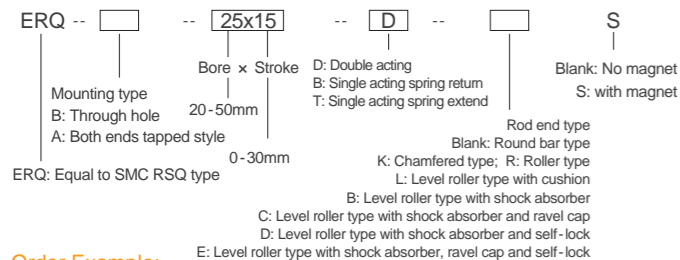

### Order Example:

ERQ Series Cylinder, Bore 20mm, stroke 15mm, through hole mounting, double acting spring, chamfered type, Model: ERQB 20 x 15BK  
ERQ Series Cylinder, Bore 40mm, stroke 30mm, with magnet, both ends tapped style, single acting spring extend, level type (with adjustable shock absorber and ravel cap), Model: ERQA 40 x 30TCS

### Specifications

Bore size(mm)	20	32	40	50
Acting type	Double Acting			
Rod ends type	Round bar type, Chamfered type, Roller type			
Working medium	Clean Air (25 μ filtration)			
Max. Working pressure (Bar)	10			
Guaranteed pressure (Bar)	15			
Working temperature ( )	-10~70 (with magnet swith:max.60 )			
Cushion	Both ends rubber cushion			
Adjusting stroke (mm)	+1.4/0			
Lubrication	Not required			
Mounting type	through hole, both ends female thread			
Port Size	RC(PT)1/8			

## SW Series Rodless Cylinder

SW Series Cylinder  
SWB15x125

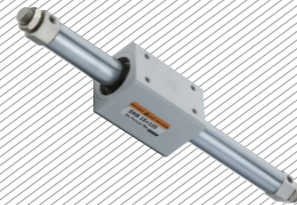

### How to Order?

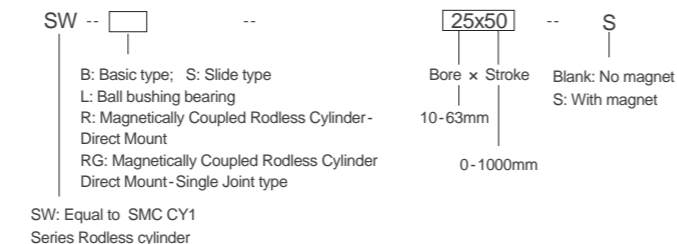

### Order Example:

SW type Rodless cylinder, basic type, 20mm bore, 50mm stroke, Model: SWB 20 x 50  
SW type Rodless cylinder, Slide type, 15mm bore, 75mm stroke, Model: SWS 15 x 75

### Specifications

Bore size(mm)	10	15	20	25	32	40	50	63
Acting type	Double Acting							
Working medium	Clean Air (25 μ filtration)							
Working pressure (Bar)	1.8~7.1							
Guaranteed pressure (Bar)	10.5							
Working temperature ( )	5~60							
Speed range (mm/s)	50~400							
Adjusting stroke (mm)	0~250: <sup>+1.0</sup> ; 251~1000: <sup>+1.40</sup> ; 1000: <sup>+1.80</sup>							
Cushion type	with rubber cushion at two sides							
Lubrication	Not required							
Port Size	M5x0.8		G1/8				G1/4	

## PCK Series Clamp Cylinder

PCK series clamp cylinder  
PCK-50x550-S-Y

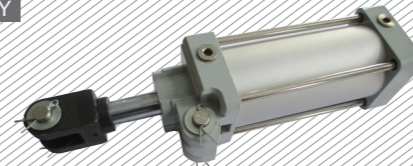

### How to Order?

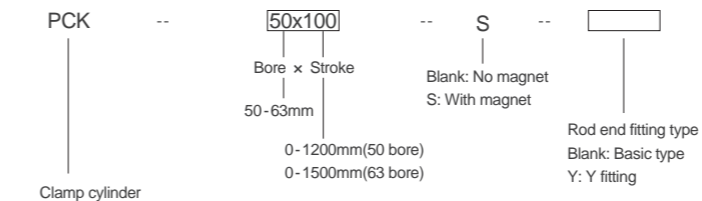

### Order Example:

PCK series, Clamp cylinder, 50mm bore, 100mm stroke, with magnet, Y fitting, Model: PCK 50x100 SY

### Specifications

Bore size(mm)	50	63
Acting type	Double Acting	
Working medium	Clean Air (25 μ filtration)	
Working pressure (Bar)	0.5~10	
Guaranteed pressure (Bar)	15	
Working temperature ( )	-5~80	
Speed range (mm/s)	50~500	
Cushion type	Adjustable Cushion	
Speed adjustable valve	Speed adjustable	
Port size	G1/4	
Mounting accessory	Y fitting (optional)	

## PHC Hydro Pneumatic Cylinder

PHC Series Cylinder  
PHCS 80 x 180-5



### How to Order?

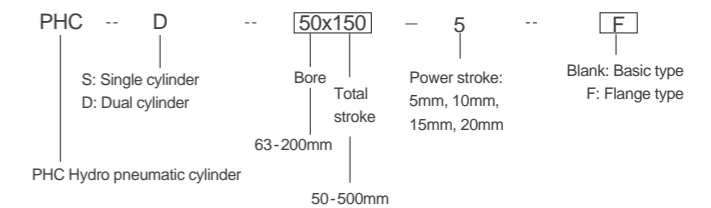

### Order Example:

PHC type Hydro pneumatic cylinder, Single cylinder, 80mm bore, 180mm stroke, 5mm Power stroke, Model: PHCS 80 x 180-5  
PHC type Hydro pneumatic cylinder, Flange type, Dual cylinder, 160mm bore, 250mm stroke, 10mm Power stroke, Model: PHCD 160 x 250-10F

### Specifications

Bore size(mm)	63	80	100	125	160	200
Working medium	Clean air with oil (Below 0.3 μ m filtration and with 1mg/m <sup>3</sup> oil)					
Guaranteed pressure (Bar)	12					
Working pressure (Bar)	2~8					
Ambient working temperature ( )	0~70					
Piston speed (mm/s)	50~200					
Output power force (kg)	1900~30000					
Return force (kg)	Be decided according to bore size, the rod diameter and working pressure					
Intermediate medium	Oil (32#~15#)					

## Technical department report

### Special Cylinder





E . MC enjoys very high reputation with strong R&D capability in China Pneumatic Industry Line. We're glad to design all kinds of special cylinder according to customers requirement.

<p>Special Cylinder RLD63x125-Y</p> 	<p>Special Cylinder EFC80x120</p> 	<p>Special Cylinder ECA80x125</p> 	<p>Special Cylinder EQG series High temperature for aluminum industry, 5-150 C</p> 
<p>Special Cylinder EG25-80</p> 	<p>Special Cylinder EHA32x250</p> 	<p>Special Cylinder RTB80x100</p> 	<p>Special Cylinder MAL20X200</p> 
<p>Special Cylinder NC50X42</p> 	<p>Special Cylinder RAS25X82-U</p> 	<p>Special Cylinder AC1X1</p> 	<p>Special Cylinder HJQG100</p> 

## Cylinder Mounting Accessories

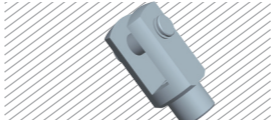
 <p>Model: VLB-32 VLB-40 VLB-50 VLB-63 VLB-80 VLB-100 VLB-125 VLB-160 VLB-200 TLB-32 TLB-40 TLB-50 TLB-63 TLB-80 TLB-100</p>	 <p>Model: VFA/VFB-32 VFA/VFB-40 VFA/VFB-50 VFA/VFB-63 VFA/VFB-80 VFA/VFB-100 VFA/VFB-125 VFA/VFB-160 VFA/VFB-200 TFA/TFB-32 TFA/TFB-40 TFA/TFB-50 TFA/TFB-63 TFA/TFB-80 TFA/TFB-100</p>	 <p>Model: VCA-32 VCA-40 VCA-50 VCA-63 VCA-80 VCA-100 VCA-125 VCA-160 VCA-200 TCA-32 TCA-40 TCA-50 TCA-63 TCA-80 TCA-100</p>	 <p>Model: VCB-32 VCB-40 VCB-50 VCB-63 VCB-80 VCB-100 VCB-125 VCB-160 VCB-200 TCB-32 TCB-40 TCB-50 TCB-63 TCB-80 TCB-100</p>
 <p>Model: TTC-32 TTC-40 TTC-50 TTC-63 TTC-80 TTC-100</p>	 <p>Model: TTC-M-32 TTC-M-40 TTC-M-50 TTC-M-63 TTC-M-80 TTC-M-100</p>	 <p>Model: VCR-32 VCR-40 VCR-50 VCR-63 VCR-80 VCR-100 VCR-125 VCR-160 VCR-200</p>	 <p>Model: ILB-16 ILB-20 ILB-25</p>
 <p>Model: ISDB-16, ISDB-20, ISDB-25</p>	 <p>Model: IFA-16 IFA-20 IFA-25</p>		

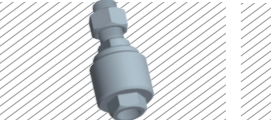
## Rod end Fitting

 <p>Model: VY-32 VY-40 VY-50 VY-63 VY-80 VY-100 VY-125 VY-160 VY-200 TY-32 TY-40 TY-50 TY-63 TY-80 TY-100</p>	 <p>Model: VYC-32 VYC-40 VYC-50 VYC-63 VYC-80 VYC-100</p>	 <p>Model: VI-32 VI-40 VI-50 VI-63 VI-80 VI-100 VI-125 VI-160 VI-200 TI-32 TI-40 TI-50 TI-63 TI-80 TI-100</p>	 <p>Model: VF-32 VF-40 VF-50 VF-63 VF-80 VF-100 VF-125 VF-160 VF-200 TF-32 TF-40 TF-50 TF-63 TF-80 TF-100</p>	 <p>Model: VB-32 VB-40 VB-50 VB-63 VB-80 VB-100 VB-125 VB-160 VB-200 TB-32 TB-40 TB-50 TB-63 TB-80 TB-100</p>
--	--	--	--	--



## Cylinder Mounting Accessories

### Specifications

Photo	Model	Type	Dimensions	Voltage	Cylinder Type
	HX-03R	Reed Switch		5~240V DC/AC	 For: IAS/IAL/RAS/RAL D6-D63 Cylinder
	HX-03N	NPN		5~30V DC/AC	
	HX-03P	PNP		5~30V DC/AC	
	HX-15R	Reed Switch		5~240V DC/AC	 For: IAS/IAL/RAS/RAL D6-D63 Cylinder
	HX-15N	NPN		5~30V DC	
	HX-15P	PNP		5~30V DC	
	HX-20R	Reed Switch		5~240V DC/AC	 For: FXBC/VBC/LBC/TBC/XBC Cylinder
	HX-20N	NPN		5~30V DC	
	HX-20P	PNP		5~30V DC	
	HX-21R	Reed Switch		5~240V DC/AC	 For: FXBC/VBC/LBC/TBC/XBC Cylinder
	HX-21N	NPN		5~30V DC	
	HX-21P	PNP		5~30V DC	
	HX-31R	Reed Switch		5~240V DC/AC	 For: FVBC Cylinder
	HX-31N	NPN		5~30V DC	
	HX-31P	PNP		5~30V DC	
	BK-81	BK series metal band			
	BK-82				
	PBN-01	PBN series metal band			
	PBN-02				
PN	PN series metal band				
	PAC	PAC series clamp			
	PM	PM series clamp			
	P1	PI series clamp			

M8, M12 Connector available

## AC Series Shock Absorber

### AC Series Shock Absorber

AC2525-1

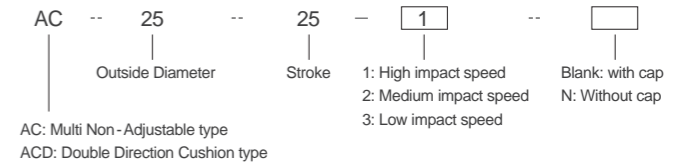

### How to Order?

#### Order Example:

AC series, high impact speed, with cap, model: AC2525-1  
ACD series, high impact speed, with cap, model: ACD2525-1

### Specifications

Model	Stroke(mm)	Max. Absorbing Energy Per Cycle (Nm)	Max. Absorbing Energy/ Hour (Nm/hr)	Max. Effective Mass (Kg)	Max. Impact speed (m/s)	Working Temperature ( )
AC0806-1	6	2	7200	0.5	2	-10~+85
AC0806-2	6	2	7200	2.0	1	-10~+85
AC0806-3	6	2	7200	6.0	0.5	-10~+85
AC1005-1	5	3	10800	1	3	-10~+85
AC1005-2	5	3	10800	3	1.5	-10~+85
AC1005-3	5	3	10800	7	0.8	-10~+85
AC1008-1	8	4	14400	2	3	-10~+85
AC1008-2	8	4	14400	4	1.5	-10~+85
AC1008-3	8	4	14400	9	0.8	-10~+85
AC1210-1	10	5	18000	5	3	-10~+85
AC1210-2	10	5	18000	10	1.5	-10~+85
AC1210-3	10	5	18000	30	0.8	-10~+85
AC1412-1	12	15	36000	8	3	-10~+85
AC1412-2	12	15	36000	50	1.5	-10~+85
AC1412-3	12	15	36000	100	0.8	-10~+85

## AC Series Shock Absorber

### Specifications

Model	Stroke(mm)	Max. Absorbing Energy Per Cycle (Nm)	Max. Absorbing Energy/ Hour (Nm/hr)	Max. Effective Mass (Kg)	Max. Impact speed (m/s)	Working Temperature ( )
AC1416-1	16	20	40000	10	3	-10~+85
AC1416-2	16	20	40000	70	1.5	-10~+85
AC1416-3	16	20	40000	150	0.8	-10~+85
AC1420-1	20	25	48000	12	3	-10~+85
AC1420-2	20	25	48000	80	1.5	-10~+85
AC1420-3	20	25	48000	160	0.8	-10~+85
AC2020-1	20	40	48000	30	3.5	-10~+85
AC2020-2	20	40	48000	200	2.0	-10~+85
AC2020-3	20	40	48000	700	1.0	-10~+85
AC2030-1	30	50	54000	30	3.5	-10~+85
AC2030-2	30	50	54000	200	2.0	-10~+85
AC2030-3	30	50	54000	700	1.0	-10~+85
AC2050-1	50	60	66000	60	3.5	-10~+85
AC2050-2	50	60	66000	400	2.0	-10~+85
AC2050-3	50	60	66000	1200	1.0	-10~+85
ACD2030-1	30	45	54000	40	3.5	-10~+85
ACD2030-2	30	45	54000	300	2.0	-10~+85
ACD2030-3	30	45	54000	900	1.0	-10~+85
ACD2035-1	35	52	62000	40	3.5	-10~+85
ACD2035-2	35	52	62000	200	2.0	-10~+85
ACD2035-3	35	52	62000	650	1.0	-10~+85
AC2525-1	25	80	60000	200	4.0	-10~+85
AC2525-2	25	80	60000	600	2.5	-10~+85
AC2525-3	25	80	60000	1000	1.0	-10~+85
AC2540-1	40	120	84000	300	4.0	-10~+85
AC2540-2	40	120	84000	800	2.5	-10~+85
AC2540-3	40	120	84000	1200	1.0	-10~+85
AC2550-1	50	98	98000	15	4.0	-10~+85
AC2550-2	50	98	98000	40	2.5	-10~+85
AC2550-3	50	98	98000	160	1.0	-10~+85
AC2580-1	80	150	127500	20	4.0	-10~+85
AC2580-2	80	150	127500	50	2.5	-10~+85
AC2580-3	80	150	127500	200	1.0	-10~+85
AC3660-1	60	250	125000	400	4.0	-10~+85
AC3660-2	60	250	125000	1500	2.5	-10~+85
AC3660-3	60	250	125000	2400	1.0	-10~+85

## AD Series Shock Absorber

### How to Order?

#### Order Example:

AD series, high impact speed, with cap, Model: AD2525-1N  
 AD series, high impact speed, without cap, Model: AD2525-1N

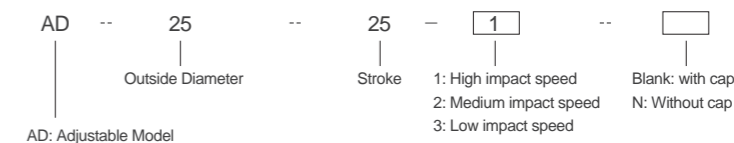

### Specifications

Model	Stroke(mm)	Max. Absorbing Energy Per Cycle (Nm)	Max. Absorbing Energy/ Hour (Nm/hr)	Max. Effective Mass (Kg)	Max. Impact speed (m/s)	Working Temperature ( )
AD1410-N/1410	10	20	24000	80	3.2	-10~+85
AD1415-N/1415	15	22	26400	120	3.2	-10~+85
AD2016N/2016	16	25	32000	200	3.6	-10~+85
AD2050-N/2050	25	39	39000	312	3.6	-10~+85
AD2525-N/2525	25	85	51000	400	3.6	-10~+85
AD2530-N/2530	30	95	57000	480	3.6	-10~+85
AD2540	40	100	84000	700	3.6	-10~+85
AD2550	50	98	98000	720	4.2	-10~+85
AD2580	80	150	127000	800	4.2	-10~+85
AD3625	25	150	90000	1400	3.2	-10~+85
AD3650	50	300	108000	1400	3.2	-10~+85
AD4225	25	260	130000	3000	3.6	-10~+85
AD4250	50	500	155000	4000	4.8	-10~+85
AD4275	75	750	187500	6000	4.8	-10~+85
AD64050	50	12000	1560000	12727	1.6	-10~+85
AD64100	100	24000	1920000	18181	1.6	-10~+85
AD64150	150	36000	2520000	23636	1.6	-10~+85

## HR Series Shock Absorber

### How to Order?

#### Order Example:

HR series, Max. stroke: 15mm, Model: HR15



### Specifications

Model	A	B	Max. stroke(mm)	Working temperature( )	Maximum load(Kgf)
HR15	157	142	15	-10~85	350
HR30	208	178	30	-10~85	350
HR60	286	225	60	-10~85	350
HR80	342	262	80	-10~85	350
HR100	396	296	100	-10~85	350

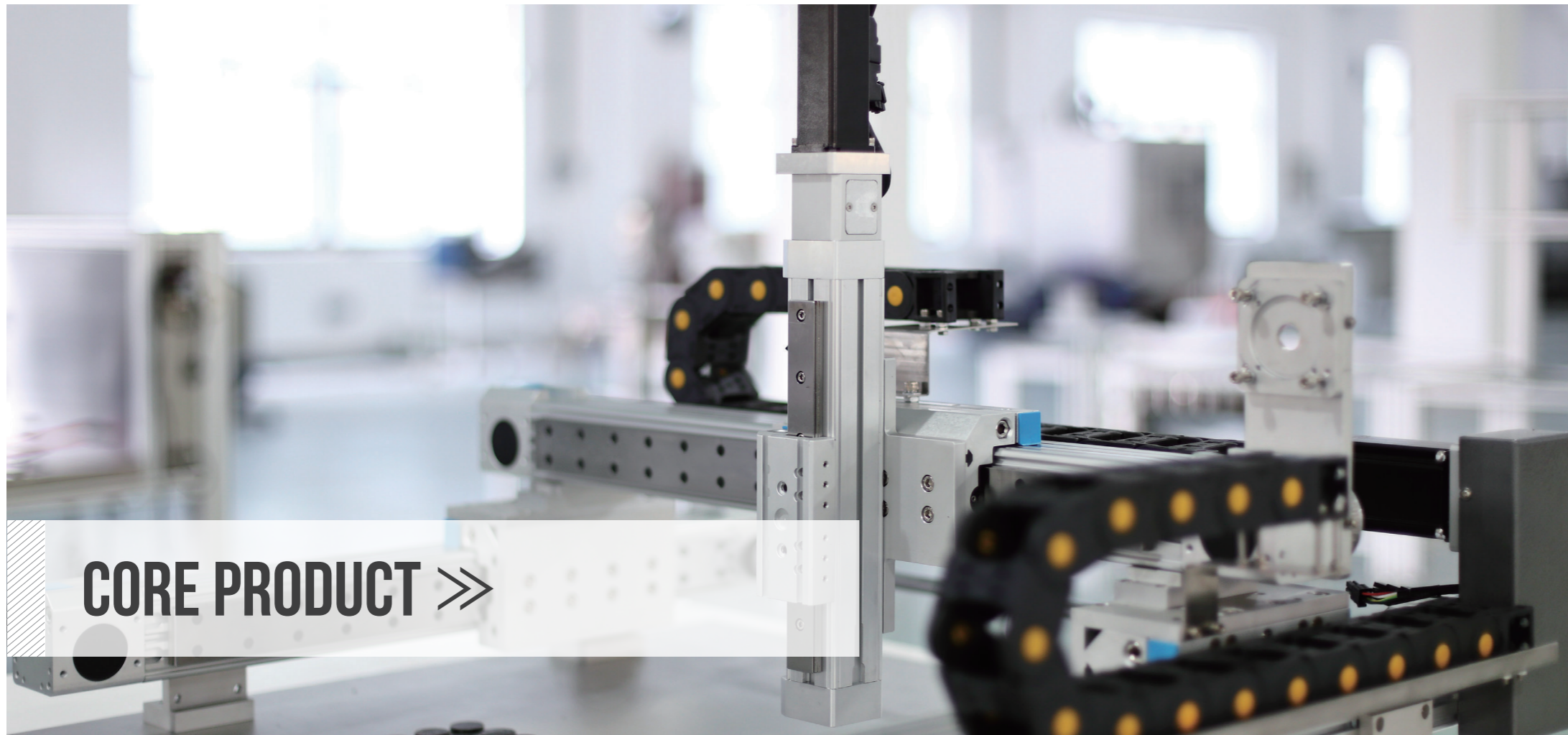

CORE PRODUCT >>

>> **Electric cylinder and intensive industry robot**

- Multiple positioning with accurate control
- High precision stroke, working at high speed very stably and without impact
- Any speed mode
- Completely E-MC R&D and manufacturing, customized intensive industry robots with 3 axis + gantry supporting axis are available

## Europe Type Cylinder Diagram

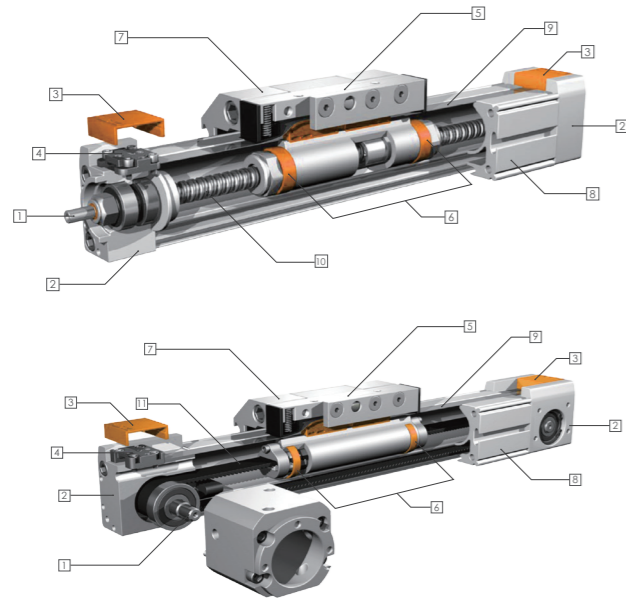

1. Spindle driver; 2. End cap; 3. Plastic cover; 4. Cover strip; 5. Slide; 6. Abrasion ring
7. Extended slide; 8. Cylinder body; 9. Steel cover; 10. Spindle; 11. Toothed belt

### How to Order?

EGE -- 25 -- 400 -- SP -- KF -- D  
 Bore size    Stroke: mm    Type    Advance:    Servo motor setup  
 D: direct    P: parallel  
 Driver function:  
 EGE: spindle axes & toothed belt axes cylinder  
 ENCE: electric cylinder  
 SP:spindle axes  
 ZR:toothed belt axes

Example:  
Toothed Belt Axes 25 Advance R Parallel

## Spindle Axes 25 Advance W Parallel

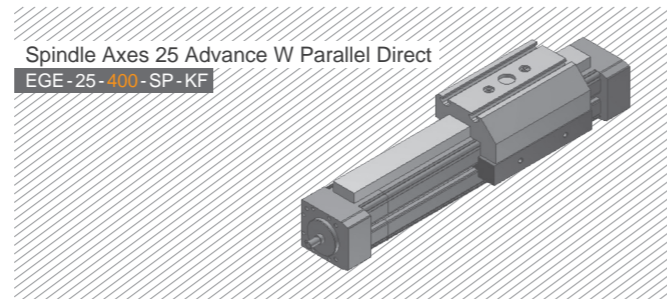

EGE: Type; 25; Bore; 400; Stroke ( Max available stroke: 1000mm); SP: Spindle axes  
KF: Wide guide

### Specifications

Power Output (W)	100W	200W	400W
Torque (Nm)	0.32	0.64	1.3
Spindle Level	C7 Spindle axes		
Drive Function	Toothed belt axes		
Repetition Accuracy (mm)	± 0.02		
Spindle diameter (mm)	12		
Pitch (mm)	10		
Max. Speed (mm/s)	500		
Max. Loads (kg)	X-axis 15	50 30	55 35
Max. Feed Force (N)	170	340	690
Stroke (mm)	1~1000		

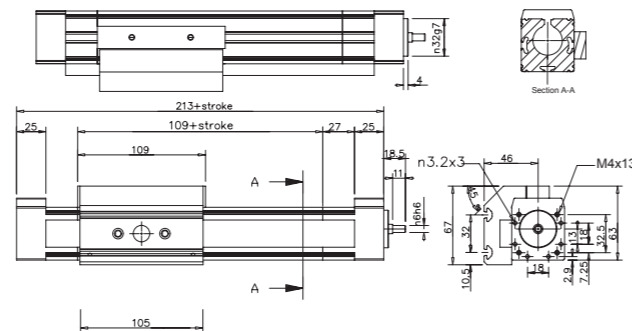

## Spindle Axes 40 Advance W Parallel Direct

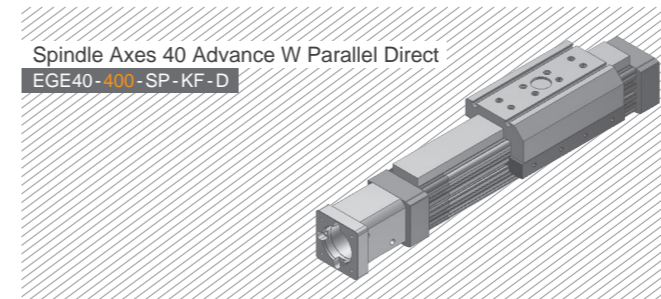

EGE: Type; 40; Bore; 400; Stroke ( Max available stroke: 1500mm); SP: Spindle axes;  
KF: Wide guide; D: Direct

### Specifications

Power Output (W)	200W	400W	750W
Torque (Nm)	0.64	1.3	2.4
Spindle Level	C7 Spindle axes		
Drive Function	Spindle axes		
Repetition Accuracy (mm)	± 0.02		
Spindle Diameter (mm)	20		
Pitch (mm)	10		
Max. Speed (mm/s)	500		
Max. Loads (kg)	X-axis 35	65 35	90 60
Max. Feed Force (N)	340	690	1280
Stroke (mm)	1~1500		

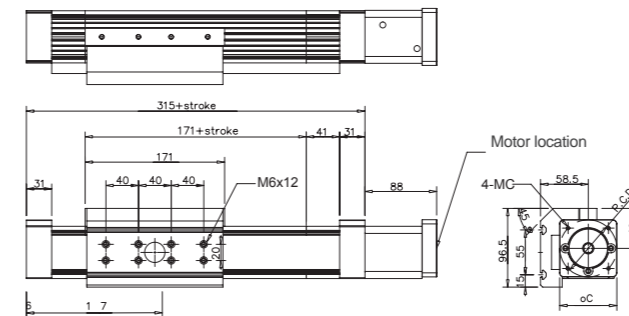

## Spindle Axes 40 Advance W Parallel

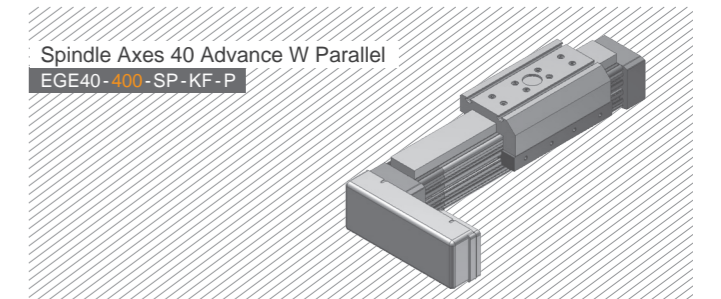

EGE: Type; 40; Bore; 400; Stroke ( Max available stroke: 1500mm); SP: Spindle axes;  
KF: Wide guide; P: Parallel

### Specifications

Power Output (W)	200W	400W	750W
Torque (Nm)	0.64	1.3	2.4
Spindle Level	C7 Spindle axes		
Drive Function	Spindle axes		
Repetition Accuracy (mm)	± 0.02		
Spindle Diameter (mm)	20		
Pitch (mm)	10		
Max. Speed (mm/s)	500		
Max. Loads (kg)	X-axis 35	65 35	90 60
Max. Feed Force (N)	340	690	1280
Stroke (mm)	1~1500		

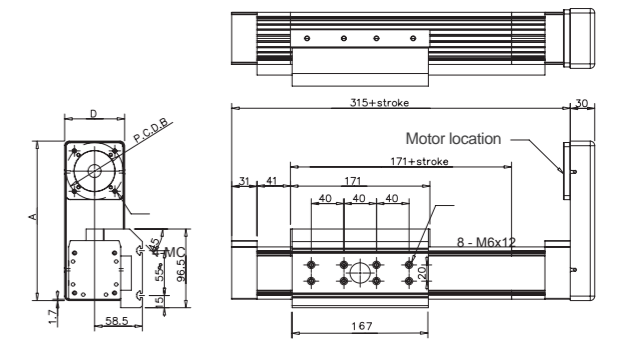

## Electric Cylinders 25 Basic

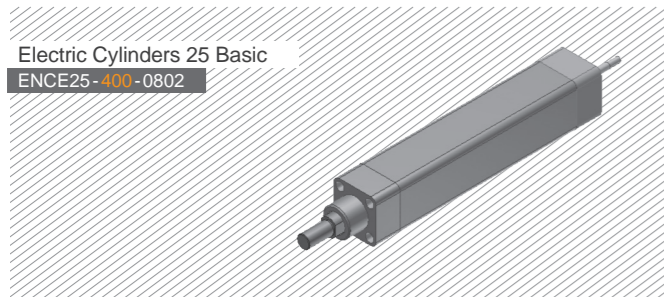

Electric Cylinders 25 Basic  
ENCE25-400-0802

ENCE: Type; 25: Bore; 400: Stroke (Max available stroke: 500mm); 0802: Spindle size

### Specifications

Power Output (W)	100W	200W
Torque (Nm)	0.32	0.64
Spindle Level	C7 Spindle axes	
Drive Function	Spindle axes	
Repetition Accuracy (mm)	± 0.02	
Spindle Diameter (mm)	8	
Pitch (mm)	2	
Max. Speed (mm/s)	100	
Max. Loads (kg)	X-axis: 70 Z-axis: 70	150
Max. Feed Force (N)	800	1700
Stroke (mm)	1-500	

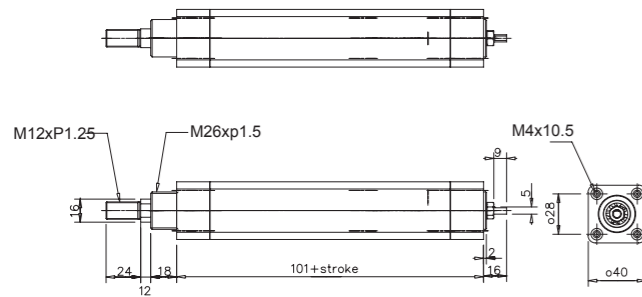

## Electric Cylinders 50 Basic

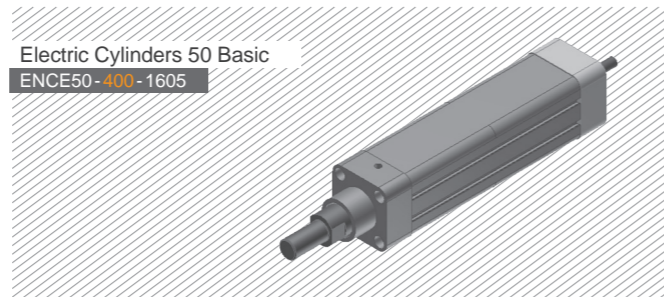

Electric Cylinders 50 Basic  
ENCE50-400-1605

ENCE: Type; 50: Bore; 400: Stroke (Max available stroke: 1200mm); 1605: Spindle size

### Specifications

Power Output (W)	200W	400W	750W
Torque (Nm)	0.64	1.3	2.4
Spindle Level	C7 Spindle axes		
Drive Function	Spindle axes		
Repetition Accuracy (mm)	± 0.02		
Spindle Diameter (mm)	16		
Pitch (mm)	5		
Max. Speed (mm/s)	250		
Max. Loads (kg)	X-axis: 60 Z-axis: 60	130	250
Max. Feed Force (N)	680	1380	2560
Stroke (mm)	1-1200		

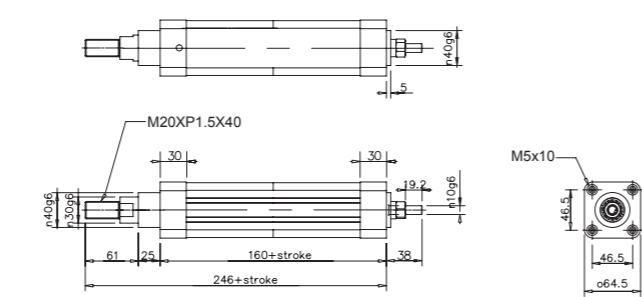

## LEFS Series Electric Cylinders



LEFS Series Electric Cylinders  
LEFS32-200

### Specifications

Bore size(mm)	32
Stroke	100,200,300,400,500,600,700,800
Work load	Horizontal: 40, 45 Vertical: 10, 20
Speed	16-500, 8-250
Max. Acceleration	3000
Position repeatability	± 0.02
Lead	16, 8
Impact	50/20
Actuation type	Ball screw
Guide type	Linear guide
Range temperature	5-40
Humidity range	90 or less(No condensation)

Bore size(mm)	32
Motor size	56.4
Motor type	step motor(servo/24 VDC)
Encoder	Incremental A/B phase(800 pulse/rotation)
Rated voltage	24VDC ± 10%
Power consumption	50
Standby power consumption when operating	44
Max. instantaneous power consumption	123
Type	non - magnetizing lock
Holding force	108, 216
Power consumption	5
Rated voltage	24VDC ± 10%

Model	L	B	n	D	E
LEFS32-100	387.5	230	4	-	-
LEFS32-200	487.5	330	6	2	300
LEFS32-300	582	430	6	2	300
LEFS32-400	682	530	8	3	450
LEFS32-500	782	630	10	4	600
LEFS32-600	882	730	10	4	600
LEFS32-700	982	830	12	5	750
LEFS32-800	1082	930	14	6	900

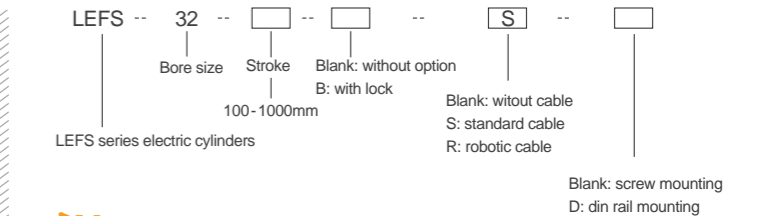

### How to Order?

#### Order Example:

LEFS series electric cylinders, bore 32mm, stroke 200 mm, without option, without cable, screw mounting, Model No.: LEFS32-200

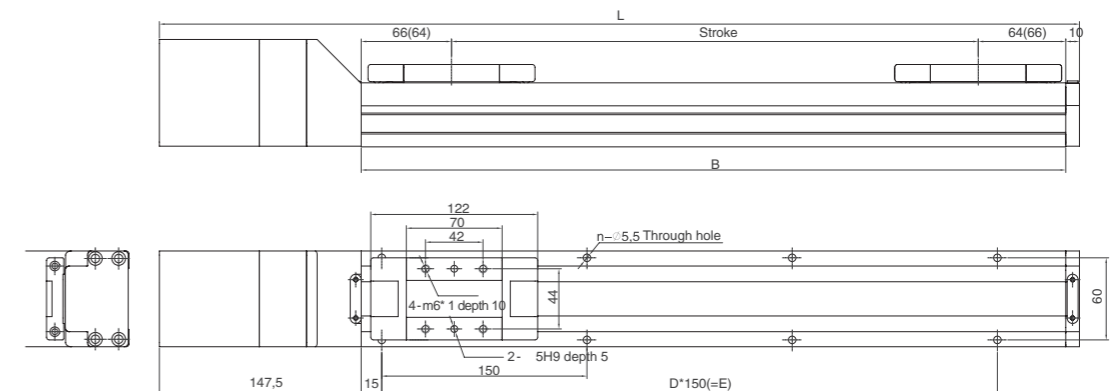

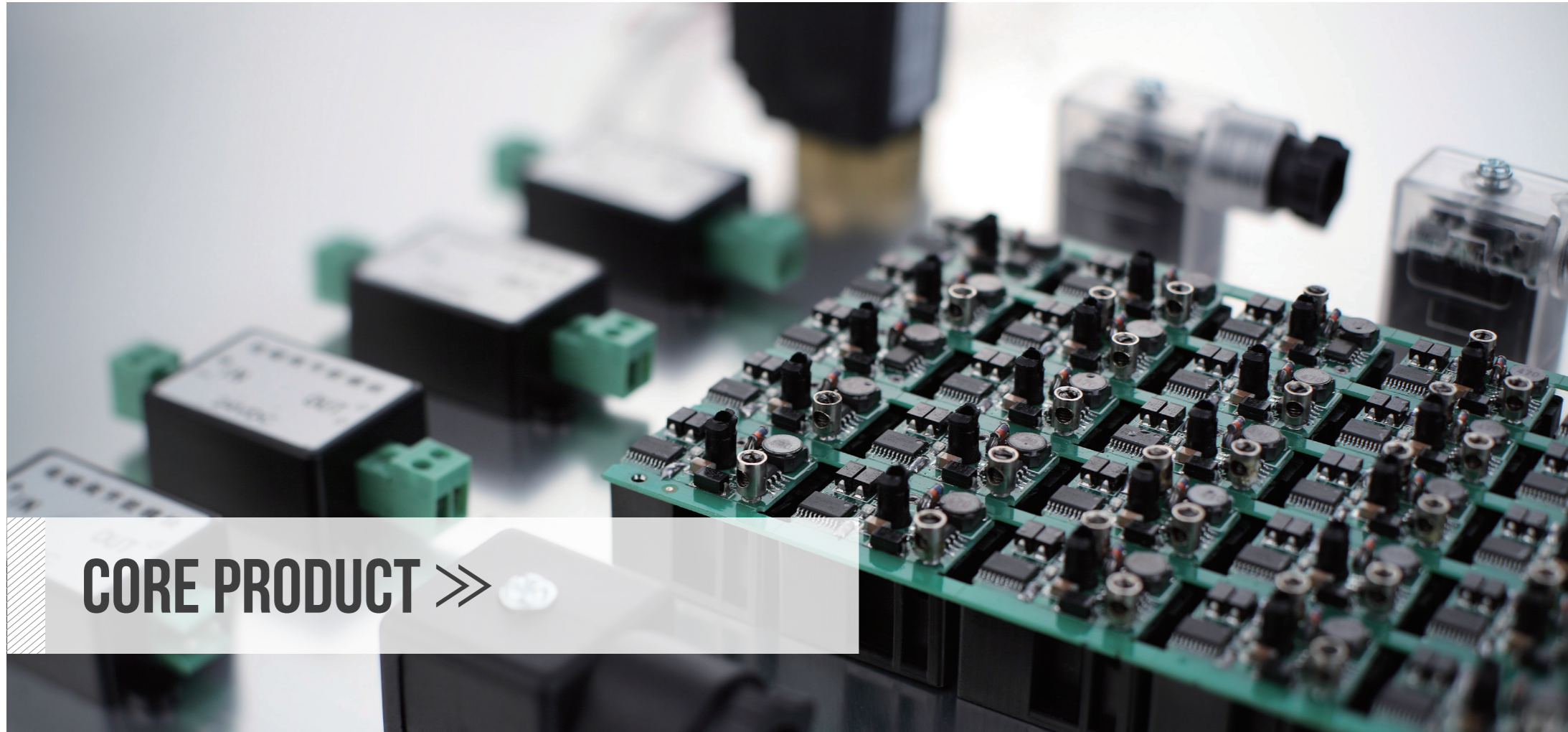

CORE PRODUCT >>

### >> Energy saving module

- Non-power driven ( IN signal working both as power supply and control signal), very convenient
- Extremely surprising power saving performance (50%-90% down), cooling down coil and elongate life
- DIN connector style makes valve more compact
- Adjustable up to 2000HZ high frequency
- Response speed of ESH2DC-A75 pressure increasing module increases 40%
- Better opening reliability of power saving DC valve

## Energy Saving Module

80~90% power saving; Strongly reducing down coil temperature; Increase opening liability of DC solenoid valve; Working at no power

### Solenoid valve use energy saving module (Fixed parameters)

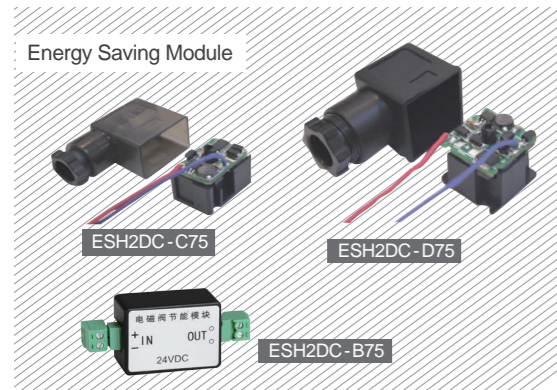

#### Specifications

Model	ESH2DC-B75 ESH2DC-C75 ESH2DC-D75
Passages	1
Inlet signal ( IN )	20~25VDC
Outlet signal ( OUT )	DC driven, max power 48W

#### How to use

ESH2DC-B75: Direct connect solenoid valve control signal to marks " IN " of the power saving module, and connect the marks " OUT " to solenoid valve. In other words, the power saving follows IN and OUT way in Series Connection way.

ESH2DC-C75/D75: Designed according DIN43650B and DIN43650A standard, direct connect to valve DIN coil

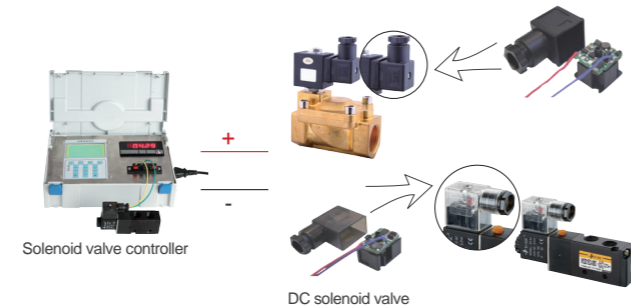
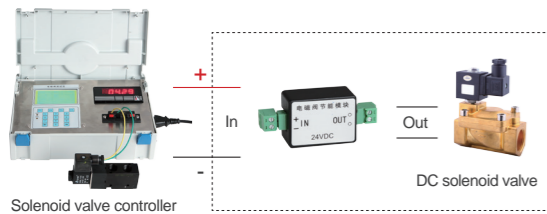

## Energy Saving Module

### General Use Energy Saving Power (Parameters Adjustable)



#### Specifications

Passages: 2 passages for ESH2DC-A75, 1 passage for ESH2DC-E75	
Inlet signal ( IN )	20~25VDC
Time adjusting P1	1~26ms
Holding voltage adjusting P2	5~14VDC
Opening voltage adjusting P3	26~39VDC
Out signal (OUT)	DC driven, max 48W

#### How to use :

Direct connect solenoid valve control signal to marks " IN " of the power saving module, and connect the marks " OUT " to solenoid valve. In other words, the power saving follows IN and OUT way in Series Connection way.

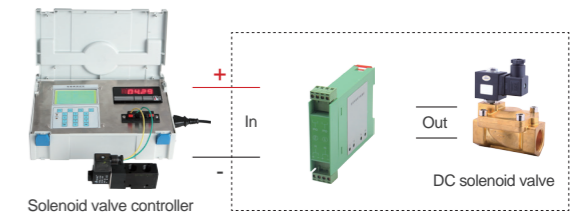
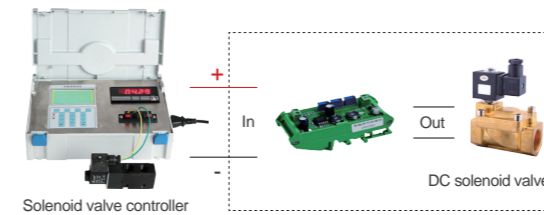

#### Note:

'IN' signal is 24VDC, which requires the power can drive solenoid valve before connecting to the module;

The module parameters are already set in production, it ' s adjustable according to valve conditions for optimization;

P11、P12、P13 and P21、P22、P23 are adjustable parameters, professional engineers are recommended to make adjustment with special instrument. (for ESH2DC-A75 and ESH2DC-E75)

### Hydraulic valve use power saving module

Personalized design for hydraulic valve, according to power, response, dimensions, working temperature, connector size. Supporting valve with voltage range 18-30V, power lower than 14W, max frequency 200HZ, power saving 50%, a specific valve needed for sampling.



## E-ZFC Series Vacuum Filter/ E-CV / E-ZU Series Vacuum Ejector

### E-ZFC series vacuum filter

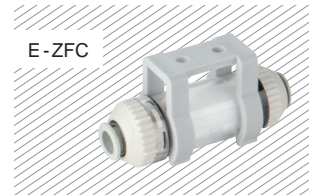

**E-ZFC** -- 100 -- 04 -- B

ZFC series vacuum filter

Flow rate  
100: Max 20L/Min  
200: Max 50L/Min  
100: Max 20L/Min  
200: Max 50L/Min

Tube size With bracket  
04: 4.0mm  
06: 6.0mm  
08: 8.0mm

Tube(Metric): E-ZFC100-04B / E-ZFC100-06B  
E-ZFC200-06B / E-ZFC200-08B

### E-CV series vacuum ejector



Item No.	Inlet	EXH
E-CV-05	1/8	1/8
E-CV-10	1/8	1/8
E-CV-15	1/4	1/4
E-CV-20	1/2	3/8

Tube(Metric): E-CV-05 / E-CV-10  
E-CV-15 / E-CV-20

### E-ZU series vacuum ejector



**E-ZU** -- 05 -- S

ZU series vacuum

Nozzle OD Vacuum  
04: 0.5mm S: -88Kpa  
06: 0.7mm L: -48Kpa

Tube(Metric): E-ZU-05-S / E-ZU-07-S  
E-ZU-05-L / E-ZU-07-L

### E-ZH series vacuum ejector S: -88 Kpa, L: -48Kpa



E-ZH05B<sup>S</sup>-06-06 / E-ZH07B<sup>S</sup>-06-06 / E-ZH10B<sup>S</sup>-06-06 / E-ZH13B<sup>S</sup>-08-10



E-ZH05B<sup>S</sup>-01-01-01 / E-ZH07B<sup>S</sup>-01-01-01 / E-ZH10B<sup>S</sup>-01-01-02  
E-ZH13B<sup>S</sup>-01-02-02 / E-ZH15B<sup>S</sup>-02-03-03



E-ZH05B<sup>S</sup>-01-01 / E-ZH07B<sup>S</sup>-01-01 / E-ZH10B<sup>S</sup>-01-01 / E-ZH13B<sup>S</sup>-01-02

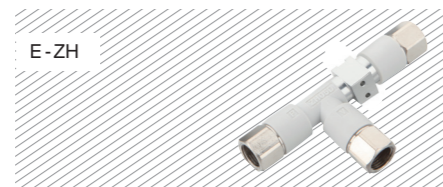

E-ZH18B<sup>S</sup>-03-03-03 / E-ZH20B<sup>S</sup>-03-04-04

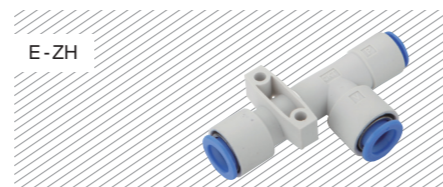

E-ZH05B<sup>S</sup>-06-06-06 / E-ZH07B<sup>S</sup>-06-06-06 / E-ZH10B<sup>S</sup>-06-06-08  
E-ZH13B<sup>S</sup>-08-10-10 / E-ZH15B<sup>S</sup>-10-12-12



E-ZH18B<sup>S</sup>-12-12-12 / E-ZH20B<sup>S</sup>-12-16-16

## Suction Pad

### VEG Series Suction Pad



**VEG** -- 10 -- N

VEG Series Pad diameter(mm) Pad material

10: 10	N: Nitrile rubber
15: 15	S: Silicon
20: 20	NE: Nitrile ESD
25: 25	SE: Silicon ESD
30: 30	

### VEK Series Suction Pad

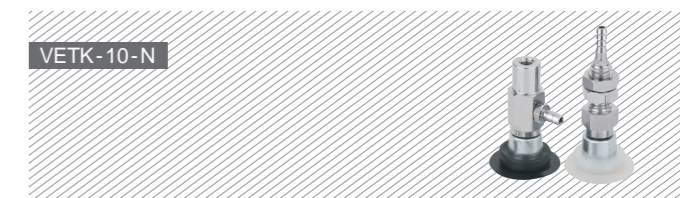

**VE** **T** **K** -- 10 -- N

VEK Series T: Vertical Y: Horizontal Pad diameter(mm) Pad material

10: 10	N: Nitrile rubber
15: 15	S: Silicon
20: 20	NE: Nitrile ESD
25: 25	SE: Silicon ESD
30: 30	

### VETS Series Suction Pad



**VETS** 10 -- 4 -- N

VETS Series Pad diameter(mm) Stroke(mm) Pad material

10: 10	4: 4	N: Nitrile rubber
15: 15	6: 6	S: Silicon
20: 20	10: 10	NE: Nitrile ESD
25: 25	15: 15	SE: Silicon ESD
30: 30	20: 20	
40: 40	30: 30	
50: 50	50: 50	

### VEYS Series Suction Pad



**VEYS** -- 10 -- 4 -- N

VEYS Series Pad diameter(mm) Stroke(mm) Pad material

10: 10	4: 4	20: 20	N: Nitrile rubber
15: 15	6: 6	30: 30	S: Silicon
20: 20	10: 10	50: 50	NE: Nitrile ESD
25: 25	15: 15		SE: Silicon ESD
30: 30			
40: 40			
50: 50			



## Suction Pad

### VEKM Series Suction Pad

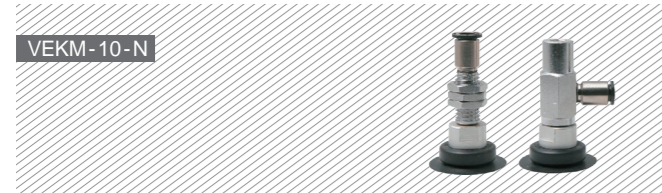

**VEKM-10-N**

VE	T	KM	--	10	--	N
VEKM Series	T: Vertical Y: Horizontal			Pad diameter(mm) 10: 10 30: 30 15: 15 40: 40 20: 20 50: 50 25: 25		Pad material N: Nitrile rubber S: Silicon NE: Nitrile ESD SE: Silicon ESD

### VECG Series Suction Pad



**VECG-10-N**

VECG	--	10	--	N
VECG Series		Pad diameter(mm) 10: 10 30: 30 15: 15 40: 40 18: 18 60: 60 20: 20 90: 90		Pad material N: Nitrile rubber S: Silicon NE: Nitrile ESD SE: Silicon ESD

### VECK Series Suction Pad

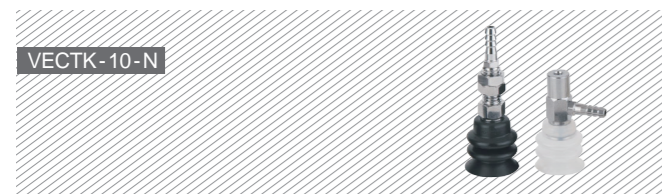

**VECK-10-N**

VEC	T	K	--	10	--	N
VECK Series	T: Vertical Y: Horizontal			Pad diameter(mm) 10: 10 30: 30 15: 15 60: 60 18: 18 20: 20		Pad material N: Nitrile rubber S: Silicon NE: Nitrile ESD SE: Silicon ESD

### VEFG Series Suction Pad



**VEFG-2-N**

VEFG	--	2	--	N
VEFG Series		Pad diameter(mm) 2: 2 15: 15 60: 60 3.5: 3.5 20: 20 80: 80 5: 5 25: 25 95: 95 6: 6 30: 30 120: 120 8: 8 35: 35 150: 150 10: 10 40: 40 200: 200 50: 50		Pad material N: Nitrile rubber S: Silicon NE: Nitrile ESD SE: Silicon ESD

## Suction Pad

### VEFTKM Series Suction Pad



**VEFTKM-2-N**

VEF	T	KM	--	2	--	N
VEFTKM Series	T: Vertical Y: Horizontal			Pad diameter(mm) 2: 2 20: 20 3.5: 3.5 25: 25 5: 5 30: 30 6: 6 35: 35 8: 8 40: 40 10: 10 50: 50 15: 15		Pad material N: Nitrile rubber S: Silicon NE: Nitrile ESD SE: Silicon ESD

### VEFK Series Suction Pad

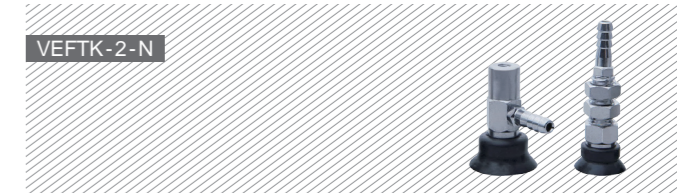

**VEFK-2-N**

VEF	T	K	--	2	--	N
VEFK Series	T: Vertical Y: Horizontal			Pad diameter(mm) 2: 2 25: 25 3.5: 3.5 30: 30 5: 5 35: 35 6: 6 40: 40 8: 8 50: 50 10: 10 60: 60 15: 15 80: 80 20: 20 95: 95		Pad material N: Nitrile rubber S: Silicon NE: Nitrile ESD SE: Silicon ESD

### VEFTS Series Suction Pad

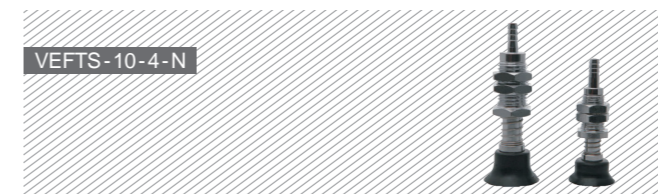

**VEFTS-10-4-N**

VEFTS	--	10	--	4	--	N
VEFTS Series		Pad diameter(mm) 2: 2 25: 25 3.5: 3.5 30: 30 5: 5 35: 35 6: 6 40: 40 8: 8 50: 50 10: 10 60: 60 15: 15 80: 80 20: 20 95: 95		Stroke(mm) 2.5: 2.5 15: 15 3: 3 20: 20 4: 4 25: 25 5: 5 30: 30 6: 6 50: 50 10: 10 70: 70		Pad material N: Nitrile rubber S: Silicon NE: Nitrile ESD SE: Silicon ESD

### VEFYS Series Suction Pad

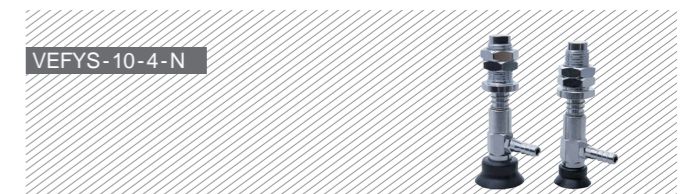

**VEFYS-10-4-N**

VEFYS	--	10	--	4	--	N
VEFYS Series		Pad diameter(mm) 2: 2 25: 25 100: 100 3.5: 3.5 30: 30 120: 120 5: 5 35: 35 150: 150 6: 6 40: 40 200: 200 8: 8 50: 50 10: 10 60: 60 15: 15 80: 80 20: 20 95: 95		Stroke(mm) 2.5: 2.5 15: 15 3: 3 20: 20 4: 4 25: 25 5: 5 30: 30 6: 6 50: 50 10: 10 70: 70		Pad material N: Nitrile rubber S: Silicon NE: Nitrile ESD SE: Silicon ESD

## Suction Pad

### VEJG Series Suction Pad



VEJG	--	10	--	N
VEJG Series	Pad diameter(mm)		Pad material	
	6: 6	35: 35	N: Nitrile rubber	
	8: 8	40: 40	S: Silicon	
	10: 10	50: 50	NE: Nitrile ESD	
	15: 15	60: 60	SE: Silicon ESD	
	20: 20			
	25: 25			
	30: 30			

### VEJK Series Suction Pad

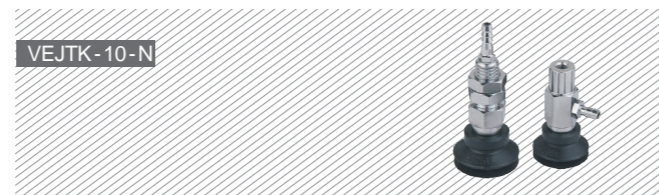

VEJ	T	K	--	10	--	N
VEJK Series	T: Vertical Y: Horizontal		Pad diameter(mm)		Pad material	
			6: 6	35: 35	N: Nitrile rubber	
			8: 8	40: 40	S: Silicon	
			10: 10	50: 50	NE: Nitrile ESD	
			15: 15		SE: Silicon ESD	
			20: 20			
			25: 25			
			30: 30			

## Suction Pad

### VES Series Suction Pad



VES	--	6	--	M	--	N
VES Series	Pad diameter(mm)		Fittings		Pad material	
	6: 6	25: 25	M: Male thread		N: Nitrile rubber	
	8: 8	30: 30	F: Female thread		S: Silicon	
	10: 10	35: 35			NE: Nitrile ESD	
	15: 15	40: 40			SE: Silicon ESD	
	20: 20	50: 50				

### VEUG Series Suction Pad



VEUG	--	80	--	N
VEUG Series	Pad diameter(mm)		Pad material	
	30: 30		N: Nitrile rubber	
	35: 35		S: Silicon	
	40: 40		NE: Nitrile ESD	
	50: 50		SE: Silicon ESD	
	60: 60			
	80: 80			
	100: 100			

### VEJTS Series Suction Pad

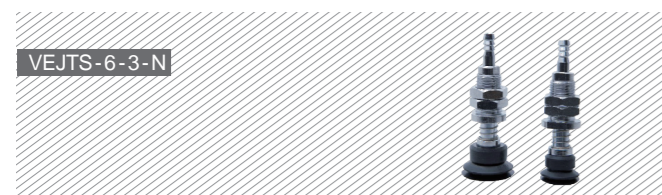

VEJTS	--	6	--	3	--	N
VEJTS Series	Pad diameter(mm)		Stroke(mm)		Pad material	
	6: 6	25: 25	3: 3	20: 20	N: Nitrile rubber	
	8: 8	30: 30	4: 4	25: 25	S: Silicon	
	10: 10	35: 35	6: 6	30: 30	NE: Nitrile ESD	
	15: 15	40: 40	10: 10	50: 50	SE: Silicon ESD	
	20: 20	50: 50	15: 15	70: 70		

### VEJYS Series Suction Pad



VEJYS	--	6	--	3	--	N
VEJYS Series	Pad diameter(mm)		Stroke(mm)		Pad material	
	6: 6	25: 25	3: 3	20: 20	N: Nitrile rubber	
	8: 8	30: 30	4: 4	25: 25	S: Silicon	
	10: 10	35: 35	6: 6	30: 30	NE: Nitrile ESD	
	15: 15	40: 40	10: 10	50: 50	SE: Silicon ESD	
	20: 20	50: 50	15: 15	70: 70		

### VEUKB Series Suction Pad



VEU	T	KB	--	80	--	N
VEUKB Series	T: Vertical Y: Horizontal		Pad diameter(mm)		Pad material	
			30: 30		N: Nitrile rubber	
			35: 35		S: Silicon	
			40: 40		NE: Nitrile ESD	
			50: 50		SE: Silicon ESD	
			60: 60			
			80: 80			
			100: 100			

### VEUSB Series Suction Pad



VEU	T	SB	--	80	--	4	--	N
VEUSB Series	T: Vertical Y: Horizontal		Pad diameter(mm)		Stroke(mm)		Pad material	
			30: 30		4: 4		N: Nitrile rubber	
			35: 35		6: 6		S: Silicon	
			40: 40		10: 10		NE: Nitrile ESD	
			50: 50		15: 15		SE: Silicon ESD	
			60: 60		20: 20			
			80: 80		30: 30			
			100: 100		50: 50			

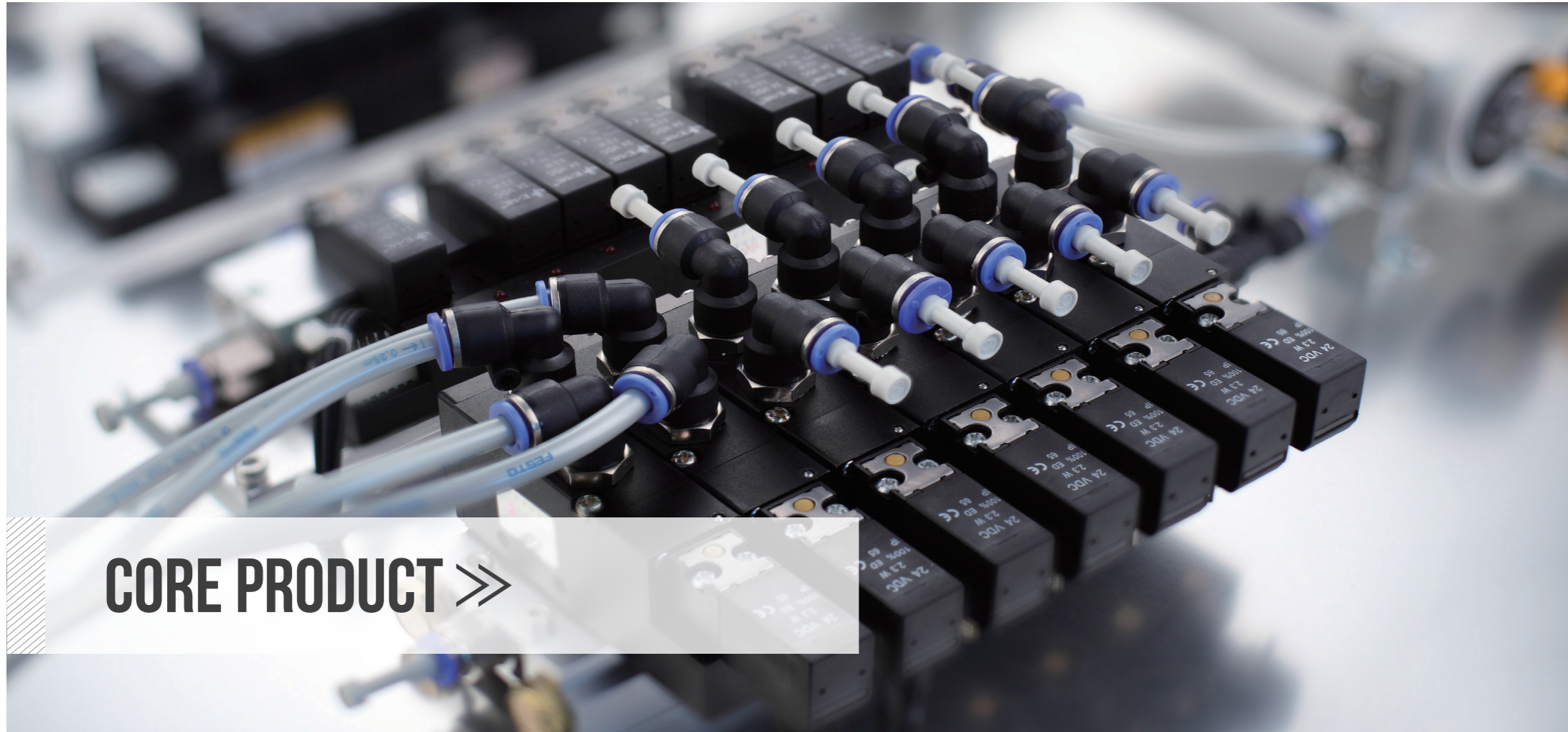

CORE PRODUCT >>

### >> Directional valve

- Fast response, high stability, 20,000,000 terrific life cycles
- Low power, high efficiency
- USA CNC machine manufacturing
- Highlighted products for process optimization
- Quality guarantee from complete automation testing of whole assembling process
- Imported sealing and grease
- Imported professional solenoid pilot production streamline
- Minimum residential magnetism with special after-treatment

## N series energy-saving solenoid valve

### How to Order?

#### Order Example:

N series energy-saving solenoid valve, 2 position 2 port, Single control, DC24V, Port size 1/8", DIN type, Model : N1M221E4-06  
 N series energy-saving solenoid valve, 2 position 3 port, Single control, DC24V, Port size 1/8", Flying leads, Model : N1M231E4-06F

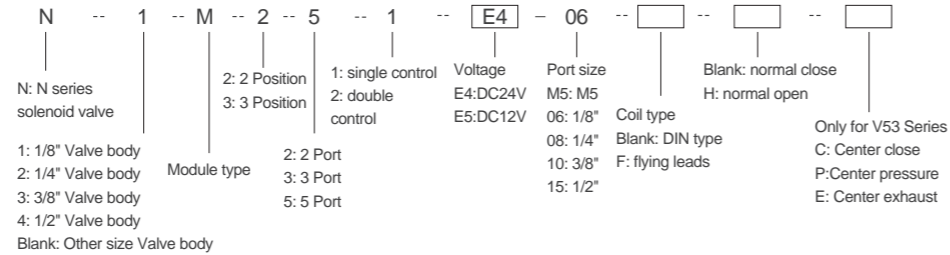

### 2 position 2 port, 2 position 3 port solenoid valve



### 2 position 5 port solenoid valve



## N series energy-saving NAMUR solenoid valve

### How to Order?

#### Order Example:

N series energy-saving solenoid valve, 2 position 5 port, Single control, 1/8" valve body, DC24V, Port size 1/8", DIN type, NAMUR valve Model : N1M251E4-06M  
 N series energy-saving solenoid valve, 2 position 5 port, Double control, 1/8" valve body, DC24V, Port size 1/8", Flying leads, NAMUR valve Model : N1M252E4-06FM

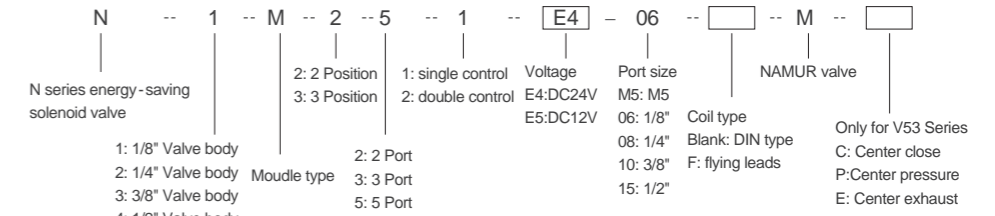

Namur valve  
 ★ ISO Standard Namur Valve

### 5 Port 2 Position Valve



## CN series 5/2 way low power solenoid valve



## V Series Solenoid & Air Control Valve

### How to Order?

**Order Example:**  
 V series, 2 port, 2 position, other size valve body, single control, AC110V, 1/8" port size, DIN coil, Model: V221E1-06  
 V series, 3 port, 2 position, other size valve body, single control, AC110V, 1/8" port size, flying leads coil, Model: V321E1-06F

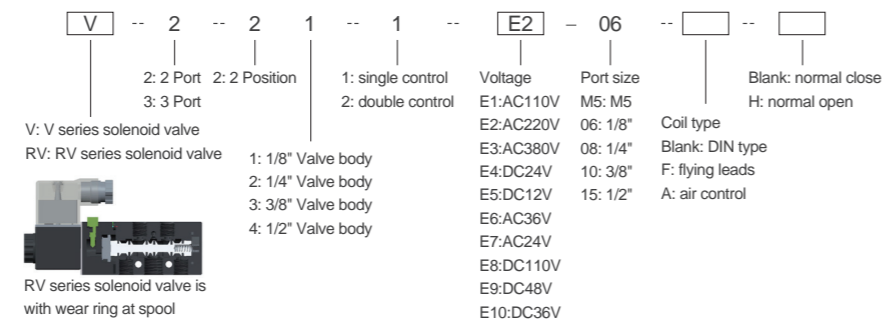

### V Series Solenoid Valve (2/2, 3/2)



### V Series Air Control Valve (3/2)

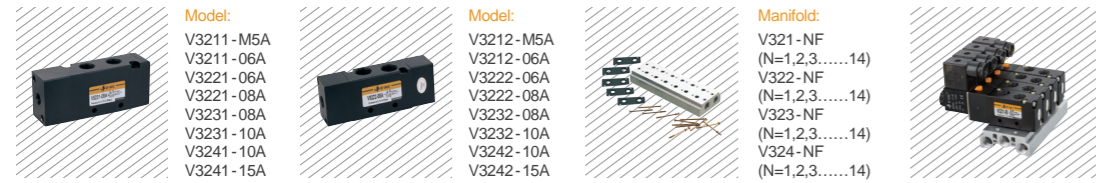

### M Series Solenoid Valve



## V Series Solenoid & Air Control Valve

### How to Order?

**Order Example:**  
 V series, 5 port, 2 position, single control, 1/8" valve body, AC110V, 1/8" port size, DIN coil, Model: V5211E1-06  
 V series, 5 port, 2 position, double control, 1/8" valve body, AC220V, 1/8" port size, flying leads coil, Model: V5212E2-06F  
 V series, 5 port, 3 position, double control, 1/8" valve body, DC24V, 1/8" port size, DIN coil, center close, Model: V5312E4-06C

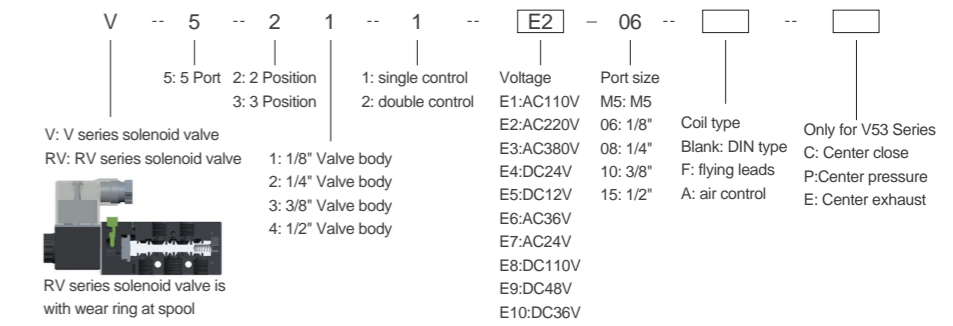

### 5 Port 2 Position Valve



### 5 Port 3 Position Valve



## V Series NAMUR Solenoid & Air Control Valve

### How to Order?

#### Order Example:

V series, 5 port ,2 position ,single control, 1/8" valve body, AC110V, 1/8" port size, DIN coil, Model : V5211E1-06M

V series, 5 port ,2 position ,double control, 1/8" valve body, AC220V, 1/8" port size, flying leads coil, Model : V5212E2-06FM

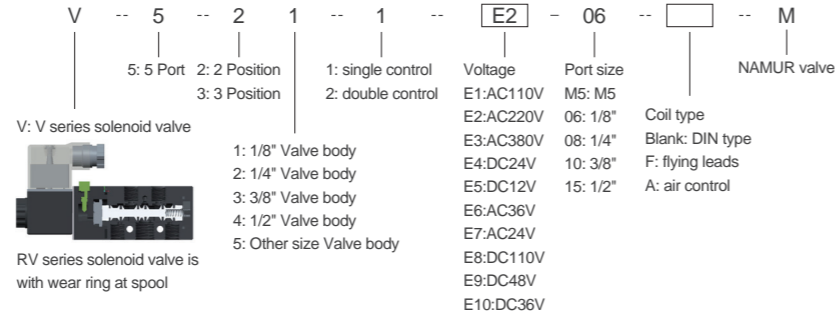

Model:  
V5211 -M5M  
V5211 -06M



Model:  
V5221 -06M  
V5221 -08M  
V5231 -08M  
V5231 -10M  
V5241 -15M



Model:  
V5212 -M5M  
V5212 -06M

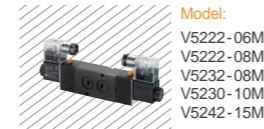

Model:  
V5222 -06M  
V5222 -08M  
V5232 -08M  
V5230 -10M  
V5242 -15M



Model:  
V3211 -M5M  
V3211 -06M



Model:  
V3221 -06M  
V3221 -08M  
V3231 -06M  
V3231 -08M  
V3231 -10M  
V3141 -15M



Model:  
V3211 -M5AM  
V3211 -06AM  
V3211 -08AM  
V3231 -06AM  
V3231 -08AM

V3231 -10AM  
V3241 -15AM  
V3251 -10AM  
V3251 -15AM



Model:  
V5211 -06AM  
V5221 -06AM  
V5231 -10AM  
V5241 -15AM



Model:  
V5212 -06AM  
V5222 -08AM  
V5232 -10AM  
V5242 -15AM



Model:  
V5312 -06AMP  
V5312 -06AMC  
V5312 -06AME  
V5322 -06AMP  
V5322 -06AMC  
V5322 -06AME

V5322 -06AME  
V5322 -08AMP  
V5322 -08AMC  
V5322 -08AME  
V5332 -08AMP  
V5332 -08AMC  
V5332 -08AME  
V5332 -10AMP  
V5332 -10AMC  
V5332 -10AME  
V5342 -15AMP  
V5342 -15AMC  
V5342 -15AME



Model:  
V5312 -M5MP  
V5312 -06MP  
V5312 -06MC  
V5312 -06ME  
V5322 -06MP  
V5322 -06MC  
V5322 -06ME

V5322 -06ME  
V5322 -08MP  
V5322 -08MC  
V5322 -08ME  
V5332 -08MP  
V5332 -08MC  
V5332 -08ME  
V5332 -10MP  
V5332 -10MC  
V5332 -10ME  
V5352 -10MP

5/2-3/2 inter change Namur valve,  
For both single and double acting,  
Outdoor use solution available



Model:  
V523231 -08MG  
V523232 -08MG

## S Series Solenoid Valve (5/2,5/3)

### How to Order?

#### Order Example:

S series, 5 port, 2 position, 1/4" body, Single control with flying leads, AC220V, 1/4" thread size, Model : S5221E2-06F

S series, 5 port, 2 position, 3/8" body, double control, 3/8" thread size, air control, Model : S5221E2-10A

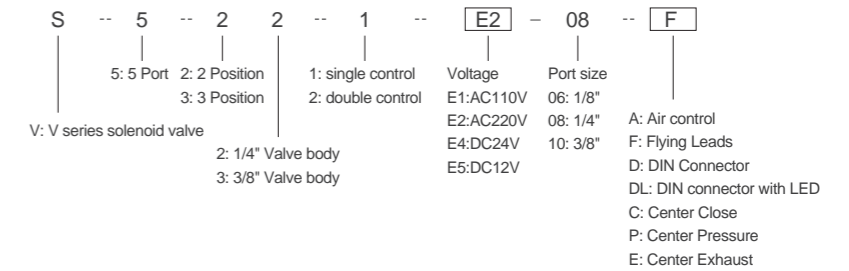

Model:  
S5221 -08F  
S5231 -10F



Model:  
S5221 -08D  
S5231 -10D



Model:  
S5221 -08DL  
S5231 -10DL

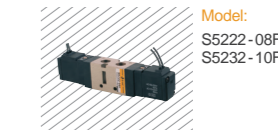

Model:  
S5222 -08F  
S5232 -10F



Model:  
S5222 -08D  
S5232 -10D

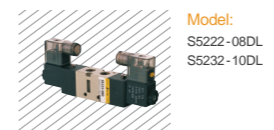

Model:  
S5222 -08DL  
S5232 -10DL



Model:  
S5322 -08FC  
S5322 -08FE  
S5322 -08FP  
S5332 -10FC  
S5332 -10FE  
S5332 -10FP

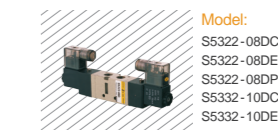

Model:  
S5322 -08DC  
S5322 -08DE  
S5322 -08DP  
S5332 -10DC  
S5332 -10DE  
S5332 -10DP



Model:  
S5322 -08DLC  
S5322 -08DLE  
S5322 -08DLP  
S5332 -10DLC  
S5332 -10DLE  
S5332 -10DLP



Model:  
S5221 -08A  
S5231 -10A



Model:  
S5222 -08A  
S5232 -10A



Model:  
S522 -NF  
(N=1,2,3,.....14)  
S523 -NF  
(N=1,2,3,.....14)

## CC Series Solenoid Valve

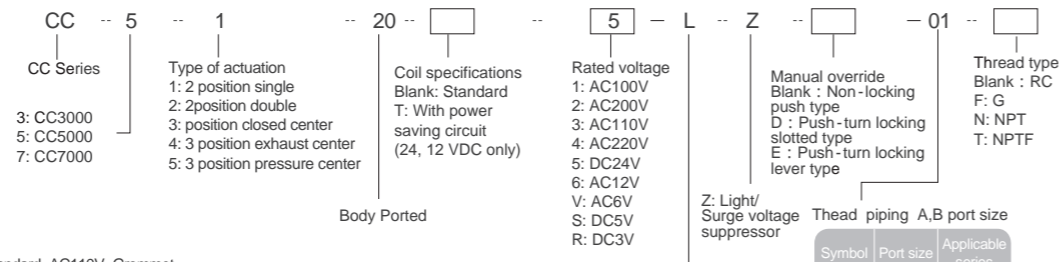

### How to Order?

#### Order Example:

CC3000 Series, 2 position single, Body ported, Standard, AC110V, Grommet, Ligh/ Surge voltage suppressor, Non-locking push type, Port size M5x0.8, RC thread, Model : CC3120T-1-G-M5  
 CC5000 Series, 2 position single, Body ported, Standard, AC200V, L plug connector, Ligh/ Surge voltage suppressor, Push-turn locking slotted type, Port size 1/8, G thread, Model : CC5120T-2-L-01-F

#### Electrical entry

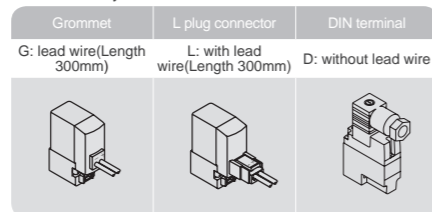

Symbol	Port size	Applicable series
M5	M5x0.8	CC3000
01	1/8	CC5000
02	1/4	CC7000

### Specifications

Model	CC3000	CC5000	CC7000
Working Medium	Air		
Internal pilot working pressure	2 Position single coil	0.15~0.7	
	2 Position double coil	0.1~0.7	
	3 Position	0.2~0.7	
Ambient temperature	-10~50 (no freezing)		
Max frequency (Hz)	2 Position single, double coil	10	5
	3 Position	3	3
Response Time (ms)	2 Position single coil	12	19
		15	32
Pilot exhaust method	Common exhaust type for main and pilot valve		
Lubrication	Not required		
Mounting	Unrestricted		
Impact	150/30		
Enclosure	Dustproof		



Model:  
CC3120-4LZD-M5  
CC3120-4LZE-M5



Model:  
CC3140-4LZD-M5  
CC3140-5LZD-M5

## CC Series Solenoid Valve

### CC5000 series

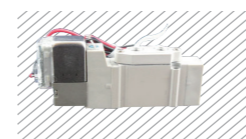

Model:  
CC3120-5GD-M5

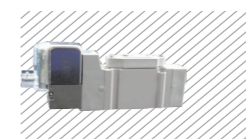

Model:  
CC3120-5LZD-M5  
CC3120-5LZE-M5

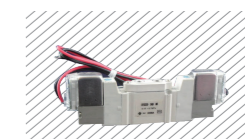

Model:  
CC3220-5GD-M5



Model:  
CC3220-4LZD-M5  
CC3220-5LZD-M5

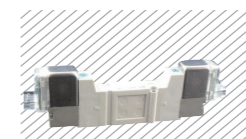

Model:  
CC3240-4LZD-M5  
CC3240-5LZD-M5



Model:  
CC3420-5LZD-M5

### CC5000 series



Model:  
CC5120-4LZD-01

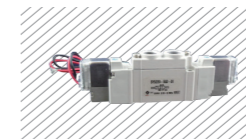

Model:  
CC5120-5GD-01



Model:  
CC5220-5LZD-01



Model:  
CC5140-4LZD-01

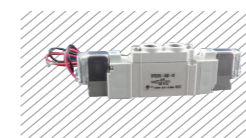

Model:  
CC5220-5GD-01



Model:  
CC5220-5LZE-01  
CC5240-5LZD-01

### CC7000 series

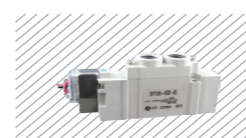

Model:  
CC7120-4LZD-02  
CC7120-6LZD-02



Model:  
CC7120-5DZD-02

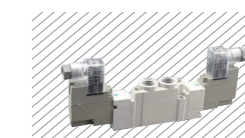

Model:  
CC7220-4LZD-02  
CC7220-5LZD-02  
CC7240-5LZD-02

## Mechanical valve

### M221 Series

Type : 2/2 Port Size : 1/4" Working Pressure : 0-8Bar Working Temperature : -5-80



M221-S1



M221-S2



M221-S3



M221-S4

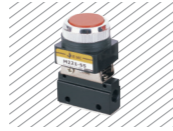

M221-S5



M221-S6



M221-S7

### MJ322 Series

Type : 3/2 Port Size : 1/4" Working Pressure : 0-8Bar Working Temperature : -5-80



MJ322-S1



MJ322-S2



MJ322-S3



MJ322-S4



MJ322-S5



MJ322-S6

### M322 Series

Type : 3/2 Port Size : 1/4" Working Pressure : 0-8Bar Working Temperature : -5-80



M322-S1



M322-S2



M322-S3



M322-S4



M322-S5



M322-S6



M322-S7

### M522 Series

Type : 5/2 Port Size : 1/4" Working Pressure : 0-8Bar Working Temperature : -5-80



M522-S1



M522-S2



M522-S3



M522-S4



M522-S5



M522-S6



M522-S7

### Hand Pull Valve

Working Pressure : 0-8Bar Working Temperature : -5-80



Model:  
L321-06 1/8"  
L322-08 1/4"  
L323-10 3/8"  
L324-15 1/2"  
Type : 3/2



Model:  
L521-06 1/8"  
L522-08 1/4"  
L523-10 3/8"  
L524-15 1/2"  
Type : 5/2

### Flow Control Valve

Working Pressure : 0-8Bar Working Temperature : -5-80



Model:  
RE-01 1/8"  
RE-02 1/4"  
RE-03 3/8"  
RE-04 1/2"



Model:  
BRE-01 1/8"  
BRE-02 1/4"  
BRE-03 3/8"  
BRE-04 1/2"

### Hand Push Valve

Working Pressure : 0-8Bar Working Temperature : -5-80



Model:  
H321-06 1/8"  
H322-08 1/4"  
H323-10 3/8"  
H324-15 1/2"  
Type : 3/2



Model:  
H521-06 1/8"  
H522-08 1/4"  
H523-10 3/8"  
H524-15 1/2"  
Type : 5/2



Model:  
H521-06S 1/8"  
H522-08S 1/4"  
H523-10S 3/8"  
H524-15S 1/2"  
Type : 5/2 Spring return



Model:  
H531-06S 1/8"  
H532-08S 1/4"  
H533-10S 3/8"  
H534-15S 1/2"  
Type : 5/3 Centere close spring return (center exhaust, center pressure is optional)



Model:  
H531-06C 1/8"  
H532-08C 1/4"  
H533-10C 3/8"  
H534-15C 1/2"  
Type : 5/3 Centere close hand push valve

### Foot Valve

Port Size : 1/4" Working Pressure : 0-8Bar Working Temperature : -5-80



Model:  
F322-08  
Type:3/2



Model:  
F422-08  
Type : 5/2



Model:  
F322-08N  
Type : 3/2



Model:  
F522-08  
Type : 5/2



Model:  
F522-08L  
Type : 5/2 with Lock



Model:  
F522C-08L  
Type:5/2 with Lock and Cover



Model:  
F522C-08  
Type : 5/2 with Cover



Model:  
F522C-08LB  
Type : 5/2 with Lock and Cover

### Rotary Valve

Type:4/3 Working Pressure : 0-8Bar Working Temperature : -5-80



Model:  
M432-08  
1/4"



Model:  
U432-08  
1/4"



Model:  
R432-08 1/4"  
R433-10 3/8"  
R434-15 1/2"



Model:  
MR432-08 1/4"  
MR433-10 3/8"  
MR434-15 1/2"

### Rotary Valve

Working Pressure : 1.5-10Bar Working Temperature : -5-60



Model:  
ES-06 1/8"  
ES-08 1/4"  
ES-10 3/8"  
ES-15 1/2"  
ES-20 3/4"  
ES-25 1"



Model:  
KKP-06 1/8"  
KKP-08 1/4"  
KKP-10 3/8"  
KKP-15 1/2"  
KKP-20 3/4"  
KKP-25 1"

Square type available

### Quick Exhaust Valve

### One Way Valve

### Silde Valve

### Pressure increase Valve



Model:  
EA-06 1/8"  
EA-08 1/4"  
EA-10 3/8"  
EA-15 1/2"  
EA-20 3/4"  
EA-25 1"



Model:  
YHS-06FM 1/8"  
YHS-08FM 1/4"  
YHS-10FM 3/8"  
YHS-15FM 1/2"  
YHS-20FM 3/4"  
YHS-25FM 1"



Model:  
VAP-06 1/8"  
VAP-08 1/4"  
VAP-10 3/8"  
VAP-15 1/2"



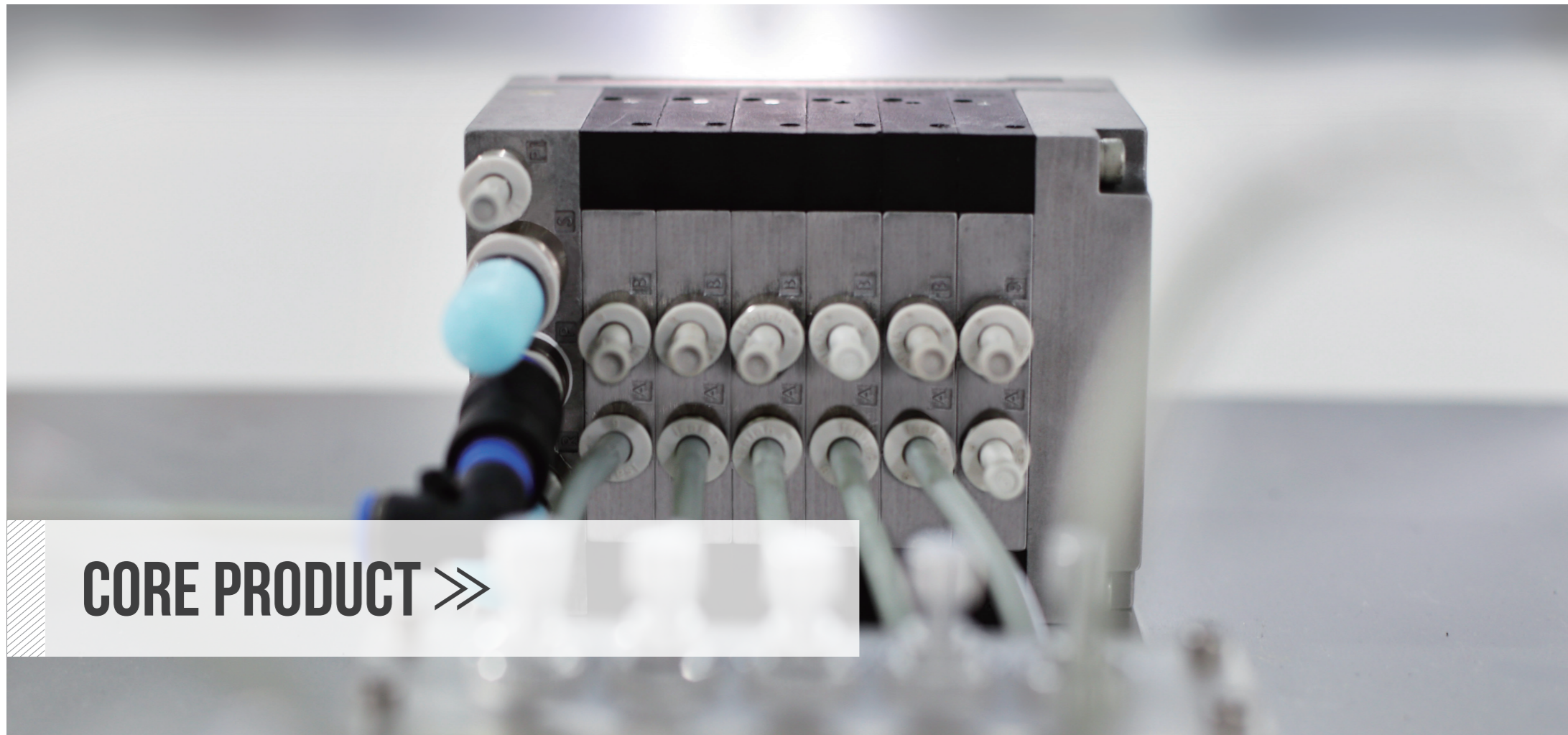

CORE PRODUCT >>

### >> Valve island

- PLC direct control
- Multi connection and interfaces
- Low power, big flow
- Compact integration modularity

## VI series valve island

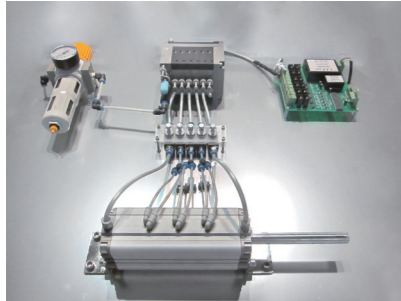

The core unit of future control system—valve island. E.MC spent 5 years on developing VI series valve island, which are widely approved by global market with fast response, smart appearance, clear electric line design. 14mm compact valve body makes max 900L/min flow, 0.6 low power, directly controlled by computer, single control respond at 15 cycles/second, while double control respond at 20 cycles/second, multiple assembling style and interface available, available with 4, 6, 8 assembly, applied in many control situation especially complex line control system. Currently, VI series valve island has full size range for 5/2 way and 3/2 way, the 5/3 way will be finished soon. In the future we will continue developing more valve island for different industry application.

### 1. Valve body design

- Different combination of valve body, side plate, spool, and seals provides various modes, including 5/2, 3/2, and 5/3 way.
- Unified valve body design to make sure all air path going well without any blocking or leaking
- 1st class facilities, e.g. Horizontal machining center gives E.MC valve island a perfect realization

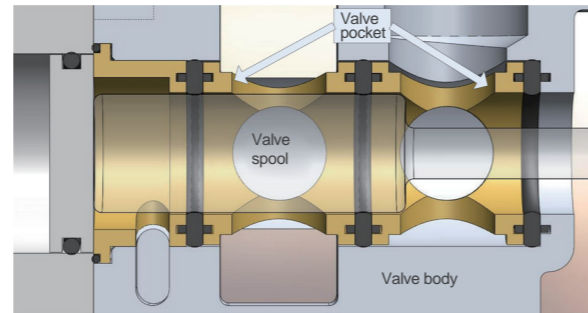

### 2. Spool and seal structure design

- Changed the structure of spring return of pneumatic components and realized air return of spool, increased valve liability and life cycle with special design
- Complete new interference structure, use valve pocket to fix and protect seals, simplify technics and elongate valve life cycles
- Seals are not mounted on spool, very convenient for mounting and maintenance by putting valve pocket and seals in our out directly.

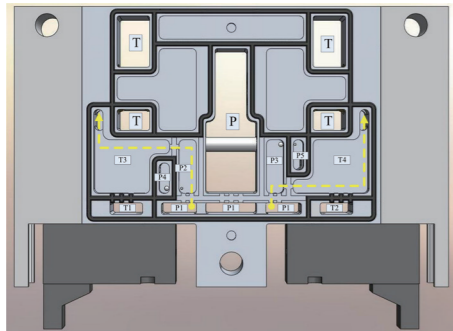

### 3. Fieldbus technology

Fieldbus module developing and extension, makes E.MC valve island widely applied in all kinds of automation manufacturing and digital control occasions.

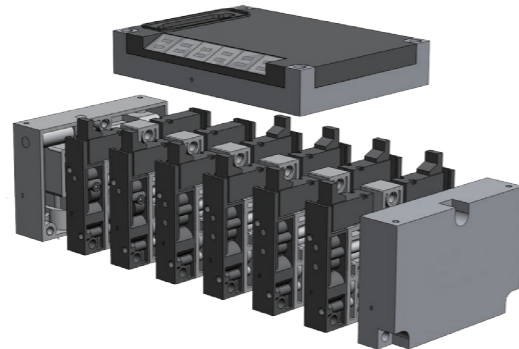

## VI Series Valve Island

Compact size; High flow rate; Multi function; Various control ways; Various mounting types

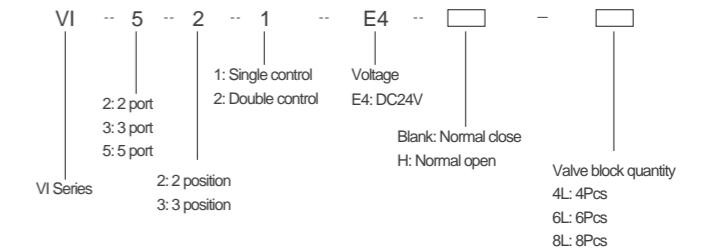

### How to Order?

#### Order Example:

VI series valve island, 3 port 2 position, single control, DC24V, normal close, Valve block quantity 6 Pcs, Model No.: VI321E4-6L

VI series valve island, 5 port 2 position, double control, DC24V, Valve block quantity 6 Pcs, Model No.: VI522E4-6L

#### Available types :

- 2/2 way Normal close & Normal open
- 2/2 way Normal close
- 2/2 way Normal open
- 3/2 way Normal close & Normal open
- 3/2 way Normal close
- 3/2 way Normal open
- 5/2 way single control
- 5/2 way double control

### Specifications

Model	VI221 E4-6L	VI221 E4H-6L	VI321 E4H-6L	VI321 E4-6L	VI322 E4-6L	VI321 E4H-6L
Working Pressure	0.1~0.8MPa					
Medium	Air					
Medium Temperature	-5~80					
Voltage	DC24V Others special made					
Voltage Tolerance	-10%~+10%					
Power	0.6W					
Body Material	Aluminum					
Seal material	NBR					

#### Features :

- Very compact valve body, 14mm thickness supports max 900L/min flow
- 0.6 Low power, directly connected to PLC
- Multiple assembling style and interface available
- Multi needle interface and all kinds of fieldbus are provided for choices
- Wide installation type including separate installation and centralized installation
- 4pc, 6pc, and 8pc valve blocks assembly are provided as standard
- Available with full size range for 5/2 way and 3/2 way, the 5/3 way will be finished soon
- Applied in many control situation especially complex line control system.



## CORE PRODUCT >>

### >> Solenoid valve

- USA CNC machine manufacturing
- Over 20 years experience in solenoid valve and coil manufacturing
- 2-8W super low power option gives the only solution for big overheat problem of solenoid valves at much lower temperature, longer life cycle, faster response, more safety use
- Big sizes ranges from 1mm to 300mm, max pressure could be over 100Bar, temperature ranges covering from -200 centigrade till +250 centigrade. The high quality from perfect design and composition of sealing and other fluid-touched part, provides customers from wide fields a best choice
- Complete automatic solenoid valve testing system.
- Imported professional solenoid pilot production streamline
- Minimum residential magnetism with special after-treatment

## ESLP Series 2/2 Solenoid Valve

### How to Order?

#### Order Example:

ESLP series, 2 port, 2 position, AC220V, 1/2" port size, Orifice: 13mm, Brass, Normal close, NBR seal, Model: SLP15E2-13L  
 ESLP series, 2 port, 2 position, AC220V, 3/4" port size, Orifice: 19mm, Brass, Normal open, VITON seal, Model: SLP20VE2-19LH

ESLP	--	06	--	[ ]	--	[E2]	-	3L	--	[S1]	--	[H]
ESLP Series NESLP series energy-saving solenoid valve (Voltage: 8-30VDC, Power: 2-6W)		Port size: 15: 1/2" 20: 3/4" 25: 1"		Seal Material Blank: NBR V: VITON E: EPDM		Voltage E1: AC110V E2: AC220V E3: AC380V E4: DC24V E5: DC12V E6: AC36V E7: AC24V E8: DC110V E9: DC48V E10: DC36V		Orifice (mm) 13L: 13 19L: 19 24L: 24		Valve Body Blank: Brass		Control Style Blank: Normal close H: Normal open

ESLP Series 2/2 Solenoid Valve

- 1.ESLP
- 2.ESLP-H

New Technology  
N.O and N.C inter change,  
1/2"~1"

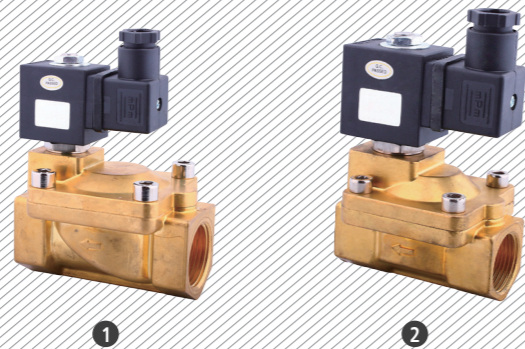

### Specifications

Port Size	Orifice (mm)	CV Value	Min. Pressure	Pressure Difference (Bar)				Max. Temperature ( )	ESLP			Modle 220VAC 50/60HZ Brass
				Max. Working Pressure					VA	W	W	
				Air / Gas	Water / Hot Water / Liquid	Light Oil	20CST		AC220	DC24V	DC24V	
1/2"	13	4.5	0.5	16	16	13	80	22	13	2.6	ESLP15E2-13L	
	13	4.5	0.5	16	16	-	130	22	13	2.6	ESLP15EE2-13L	
	13	4.5	0.5	16	16	13	120	22	13	2.6	ESLP15VE2-13L	
3/4"	19	7.6	0.5	16	16	13	80	22	13	2.6	ESLP20E2-19L	
	19	7.6	0.5	16	16	-	130	22	13	2.6	ESLP20EE2-19L	
	19	7.6	0.5	16	16	13	120	22	13	2.6	ESLP20VE2-19L	
1"	24	12	0.5	16	16	13	80	22	13	2.6	ESLP25E2-24L	
	24	12	0.5	16	16	-	130	22	13	2.6	ESLP25EE2-24L	
	24	12	0.5	16	16	13	120	22	13	2.6	ESLP25VE2-24L	

## SLP Series 2/2 Solenoid Valve

### How to Order?

#### Order Example:

SLP series, 2 port, 2 position, AC110V, 1/8" port size, Orifice: 3mm, Brass, Normal close, NBR seal, Model: SLP06E1-3L  
 SLP series, 2 port, 2 position, AC220V, 3/8" port size, Orifice: 13mm, SS316, Normal open, VITON seal, Model: SLP10VE2-13LS1H

SLP	--	06	--	[ ]	--	[E2]	-	3L	--	[S1]	--	[H]
SLP Series NSLP series energy-saving solenoid valve (Voltage: 8-30VDC, Power: 2-6W)		Port size: 06: 1/8" 08: 1/4" 10: 3/8" 15: 1/2" 20: 3/4" 25: 1" 35: 1-1/4" 40: 1-1/2" 50: 2" F: Flange		Seal Material Blank: NBR V: VITON E: EPDM		Voltage E1: AC110V E2: AC220V E3: AC380V E4: DC24V E5: DC12V E6: AC36V E7: AC24V E8: DC110V E9: DC48V E10: DC36V		Orifice (mm) 3L: 3 4L: 4 10.5L: 10.5 13L: 13 20L: 20 25L: 25 35L: 35 40L: 40 50L: 50 65L: 65 80L: 80 100L: 100		Valve Body Blank: Brass S1: SS316		Control Style Blank: Normal close H: Normal open

Cancel if same with port size

SLP Series 2/2 Solenoid Valve

- 1.SLP
- 2.SLP-S1
- 3.SLPF-S1

16 Bar, 1/8"~4"



### Specifications

Port Size	Orifice (mm)	CV Value	Min. Pressure	Pressure Difference (Bar)				Max. Temperature ( )	SLP			Modle 220VAC 50/60HZ Brass	Stainless Steel
				Max. Working Pressure					VA	W	W		
				Air / Gas	Water / Hot Water / Liquid	Light Oil	20CST		AC220	DC24V	DC24V		
1/8"	3	0.23	0	13	13	10	80	22	13	2.6	SLP06E2-3L	SLP06E2-3LS1	
	3	0.23	0	13	13	-	130	22	13	2.6	SLP06EE2-3L	SLP06EE2-3LS1	
	3	0.23	0	13	13	10	120	22	13	2.6	SLP06VE2-3L	SLP06VE2-3LS1	
1/4"	3	0.23	0	13	13	10	80	22	13	2.6	SLP08E2-3L	SLP08E2-3LS1	
	3	0.23	0	13	13	-	130	22	13	2.6	SLP08EE2-3L	SLP08EE2-3LS1	
	3	0.23	0	13	13	10	120	22	13	2.6	SLP08VE2-3L	SLP08VE2-3LS1	
1"	10.5	1.47	0	16	16	13	80	22	13	2.6	SLP08E2-10.5L	-	
	10.5	1.47	0	16	16	-	130	22	13	2.6	SLP08EE2-10.5L	-	
	10.5	1.47	0	16	16	13	120	22	13	2.6	SLP08VE2-10.5L	-	

### SLP Series 2/2 Solenoid Valve

Port Size	Orifice (mm)	CV Value	Pressure Difference (Bar)				Max. Temperature (°C)	SLP			NSLP		Model 220VAC 50/60HZ	
			Min. Pressure	Max. Working Pressure				VA	W	W	Brass	Stainless Steel		
				Air / Gas	Water / Hot Water / Liquid	Light Oil 20CSTT								
3/8"	3	0.3	0	13	13	10	80	22	13	2.6	SLP10E2-3L	SLP10E2-3LS1		
	3	0.3	0	13	13	10	130	22	13	2.6	SLP10EE2-3L	SLP10EE2-3LS1		
	3	0.3	0	13	13	10	120	22	13	2.6	SLP10VE2-3L	SLP10VE2-3LS1		
	4	0.6	0	8	8	6	80	22	13	2.6	SLP10E2-4L	SLP10E2-4LS1		
	4	0.6	0	8	8	6	130	22	13	2.6	SLP10EE2-4L	SLP10EE2-4LS1		
	4	0.6	0	8	8	6	120	22	13	2.6	SLP10VE2-4L	SLP10VE2-4LS1		
	10.5	1.68	0	16	16	13	80	22	13	2.6	SLP10E2-10.5L	-		
	10.5	1.68	0	16	16	-	130	22	13	2.6	SLP10EE2-10.5L	-		
	10.5	1.68	0	16	16	13	120	22	13	2.6	SLP10VE2-10.5L	-		
	13	4.5	0.5	16	16	13	80	22	13	2.6	SLP10E2-13L	SLP10E2-13LS1		
13	4.5	0.5	16	16	-	130	22	13	2.6	SLP10EE2-13L	SLP10EE2-13LS1			
13	4.5	0.5	16	16	13	120	22	13	2.6	SLP10VE2-13L	SLP10VE2-13LS1			
10.5	1.75	0	16	16	13	80	22	13	2.6	SLP15E2-10.5L	-			
10.5	1.75	0	16	16	-	130	22	13	2.6	SLP15EE2-10.5L	-			
10.5	1.75	0	16	16	13	120	22	13	2.6	SLP15VE2-10.5L	-			
1/2"	13	4.5	0.5	16	16	13	80	22	13	2.6	SLP15E2-13L	SLP15E2-13LS1		
	13	4.5	0.5	16	16	-	130	22	13	2.6	SLP15EE2-13L	SLP15EE2-13LS1		
	13	4.5	0.5	16	16	13	120	22	13	2.6	SLP15VE2-13L	SLP15VE2-13LS1		
3/4"	20	7.6	0.5	16	16	13	80	22	13	2.6	SLP-20E2	SLP-20E2S1		
	20	7.6	0.5	16	16	-	130	22	13	2.6	SLP-20EE2	SLP-20EE2S1		
	20	7.6	0.5	16	16	13	120	22	13	2.6	SLP-20VE2	SLP-20VE2S1		
1"	25	12	0.5	16	16	13	80	22	13	2.6	SLP-25E2	SLP-25E2S1		
	25	12	0.5	16	16	-	130	22	13	2.6	SLP-25EE2	SLP-25EE2S1		
	25	12	0.5	16	16	13	120	22	13	2.6	SLP-25VE2	SLP-25VE2S1		
1-1/4"	35	22	0.5	16	16	13	80	22	13	2.6	SLP-35E2	SLP-35E2S1		
	35	22	0.5	16	16	-	130	22	13	2.6	SLP-35EE2	SLP-35EE2S1		
	35	22	0.5	16	16	13	120	22	13	2.6	SLP-35VE2	SLP-35VE2S1		
1-1/2"	40	30	0.5	16	16	13	80	22	13	2.6	SLP-40E2	SLP-40E2S1		
	40	30	0.5	16	16	-	130	22	13	2.6	SLP-40EE2	SLP-40EE2S1		
	40	30	0.5	16	16	13	120	22	13	2.6	SLP-40VE2	SLP-40VE2S1		
2"	50	48	0.5	16	16	13	80	22	13	2.6	SLP-50E2	SLP-50E2S1		
	50	48	0.5	16	16	-	130	22	13	2.6	SLP-50EE2	SLP-50EE2S1		
	50	48	0.5	16	16	13	120	22	13	2.6	SLP-50VE2	SLP-50VE2S1		
Flange 4 ports	25	12	0.5	16	16	13	80	22	13	2.6	-	SLPFE2-25LS1		
	25	12	0.5	16	16	-	130	22	13	2.6	-	SLPFEE2-25LS1		
	25	12	0.5	16	16	13	120	22	13	2.6	-	SLPFVE2-25LS1		
	35	22	0.5	16	16	13	80	22	13	2.6	-	SLPFE2-35LS1		
	35	22	0.5	16	16	-	130	22	13	2.6	-	SLPFEE2-35LS1		
	35	22	0.5	16	16	13	120	22	13	2.6	-	SLPFVE2-35LS1		
	40	30	0.5	16	16	13	80	22	13	2.6	-	SLPFE2-40LS1		
	40	30	0.5	16	16	-	130	22	13	2.6	-	SLPFEE2-40LS1		
	40	30	0.5	16	16	13	120	22	13	2.6	-	SLPFVE2-40LS1		
	50	48	0.5	16	16	13	80	22	13	2.6	-	SLPFE2-50LS1		
	50	48	0.5	16	16	-	130	22	13	2.6	-	SLPFEE2-50LS1		
	50	48	0.5	16	16	13	120	22	13	2.6	-	SLPFVE2-50LS1		
	65	52	0.5	12	12	8	80	33	20	4	-	SLPFE2-65LS1		
	65	52	0.5	12	12	-	120	33	20	4	-	SLPFEE2-65LS1		
	65	52	0.5	12	12	8	120	33	20	4	-	SLPFVE2-65LS1		
	80	80	0.5	12	12	8	80	33	20	4	-	SLPFE2-80LS1		
	80	80	0.5	12	12	-	120	33	20	4	-	SLPFEE2-80LS1		
	80	80	0.5	12	12	8	120	33	20	4	-	SLPFVE2-80LS1		
	100	128	0.5	12	12	8	80	33	20	4	-	SLPFE2-100LS1		
	100	128	0.5	12	12	-	120	33	20	4	-	SLPFEE2-100LS1		
100	128	0.5	12	12	8	120	33	20	4	-	SLPFVE2-100LS1			

### SLP-H 2/2 Solenoid Valve(Normal Open)

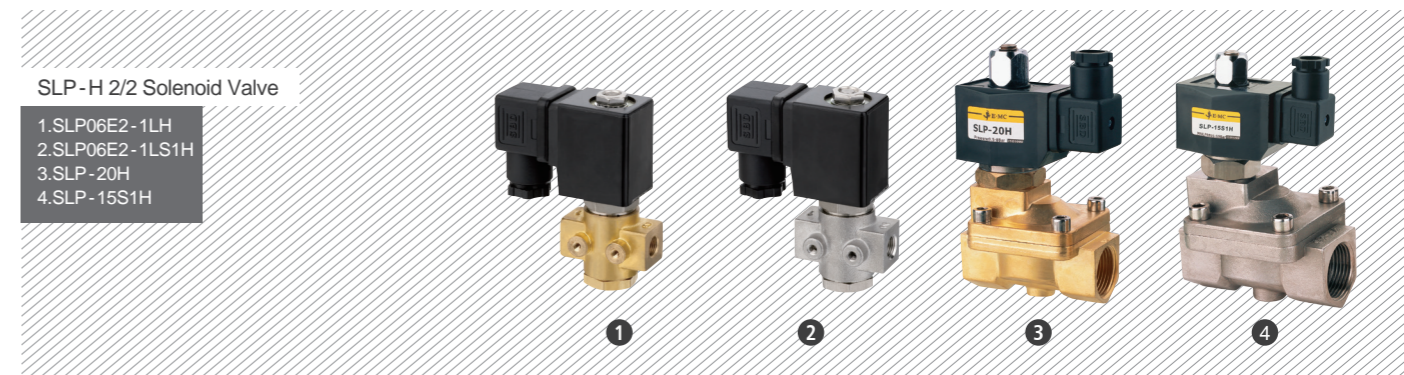

SLP-H 2/2 Solenoid Valve

- 1.SLP06E2-1LH
- 2.SLP06E2-1LS1H
- 3.SLP-20H
- 4.SLP-15S1H

### Specifications

Port Size	Orifice (mm)	CV Value	Pressure Difference (Bar)				Max. Temperature (°C)	SLP			NSLP		Model 220VAC 50/60HZ	
			Min. Pressure	Max. Working Pressure				VA	W	W	Brass	Stainless Steel		
				Air / Gas	Water / Hot Water / Liquid	Light Oil 20CSTT								
1/8"	1	0.04	0	30	30	25	80	22	13	2.6	SLP06E2-1LH	SLP06E2-1LS1H		
	1	0.04	0	30	30	-	130	22	13	2.6	SLP06EE2-1LH	SLP06EE2-1LS1H		
	1	0.04	0	30	30	25	120	22	13	2.6	SLP06VE2-1LH	SLP06VE2-1LS1H		
	1.5	0.09	0	20	20	15	80	22	13	2.6	SLP06E2-1.5LH	SLP06E2-1.5LS1H		
	1.5	0.09	0	20	20	-	130	22	13	2.6	SLP06EE2-1.5LH	SLP06EE2-1.5LS1H		
	1.5	0.09	0	20	20	15	120	22	13	2.6	SLP06VE2-1.5LH	SLP06VE2-1.5LS1H		
	2.5	0.2	0	15	15	12	80	22	13	2.6	SLP06E2-2.5LH	SLP06E2-2.5LS1H		
	2.5	0.2	0	15	15	-	130	22	13	2.6	SLP06EE2-2.5LH	SLP06EE2-2.5LS1H		
	2.5	0.2	0	15	15	12	120	22	13	2.6	SLP06VE2-2.5LH	SLP06VE2-2.5LS1H		
	3	0.25	0	12	12	10	80	22	13	2.6	SLP06E2-3LH	SLP06E2-3LS1H		
3	0.25	0	12	12	-	130	22	13	2.6	SLP06EE2-3LH	SLP06EE2-3LS1H			
3	0.25	0	12	12	10	120	22	13	2.6	SLP06VE2-3LH	SLP06VE2-3LS1H			
1/4"	1	0.04	0	30	30	25	80	22	13	2.6	SLP08E2-1LH	SLP08E2-1LS1H		
	1	0.04	0	30	30	-	130	22	13	2.6	SLP08EE2-1LH	SLP08EE2-1LS1H		
	1	0.04	0	30	30	25	120	22	13	2.6	SLP08VE2-1LH	SLP08VE2-1LS1H		
	1.5	0.09	0	20	20	15	80	22	13	2.6	SLP08E2-1.5LH	SLP08E2-1.5LS1H		
	1.5	0.09	0	20	20	-	130	22	13	2.6	SLP08EE2-1.5LH	SLP08EE2-1.5LS1H		
	1.5	0.09	0	20	20	15	120	22	13	2.6	SLP08VE2-1.5LH	SLP08VE2-1.5LS1H		
	2.5	0.2	0	15	15	12	80	22	13	2.6	SLP08E2-2.5LH	SLP08E2-2.5LS1H		
	2.5	0.2	0	15	15	-	130	22	13	2.6	SLP08EE2-2.5LH	SLP08EE2-2.5LS1H		
	2.5	0.2	0	15	15	12	120	22	13	2.6	SLP08VE2-2.5LH	SLP08VE2-2.5LS1H		
	3	0.25	0	12	12	10	80	22	13	2.6	SLP08E2-3LH	SLP08E2-3LS1H		
3	0.25	0	12	12	-	130	22	13	2.6	SLP08EE2-3LH	SLP08EE2-3LS1H			
3	0.25	0	12	12	10	120	22	13	2.6	SLP08VE2-3LH	SLP08VE2-3LS1H			

## SLP-H 2/2 Solenoid Valve(Normal Open)

### Specifications

Port Size	Orifice (mm)	CV Value	Pressure Difference (Bar)				Max. Temperature ( )	SLP			Model 220VAC 50/60HZ	
			Min. Pressure	Max. Working Pressure				VA	W	NSLP	Brass	Stainless Steel
				Air / Gas	Water / Hot Water / Liquid	Light Oil						
3/8"	13	4.5	0.5	8	8	7	80	20	20	4	SLP10E2-13LH	SLP10E2-13LS1H
	13	4.5	0.5	8	8	-	120	20	20	4	SLP10EE2-13LH	SLP10EE2-13LS1H
	13	4.5	0.5	8	8	7	120	20	20	4	SLP10VE2-13LH	SLP10VE2-13LS1H
1/2"	13	4.5	0.5	8	8	7	80	20	20	4	SLP15E2-13LH	SLP15E2-13LS1H
	13	4.5	0.5	8	8	-	120	20	20	4	SLP15EE2-13LH	SLP15EE2-13LS1H
	13	4.5	0.5	8	8	7	120	20	20	4	SLP15VE2-13LH	SLP15VE2-13LS1H
3/4"	20	7.6	0.5	8	8	7	80	20	20	4	SLP-20E2H	SLP-20E2S1H
	20	7.6	0.5	8	8	-	120	20	20	4	SLP-20EE2H	SLP-20EE2S1H
	20	7.6	0.5	8	8	7	120	20	20	4	SLP-20VE2H	SLP-20VE2S1H
1"	25	12	0.5	8	8	7	80	20	20	4	SLP-20E2H	SLP-25E2S1H
	25	12	0.5	8	8	-	120	20	20	4	SLP-25EE2H	SLP-25EE2S1H
	25	12	0.5	8	8	7	120	20	20	4	SLP-25VE2H	SLP-25VE2S1H
1-1/4"	35	22	0.5	8	8	7	80	20	20	4	SLP-35E2H	SLP-35E2S1H
	35	22	0.5	8	8	-	120	20	20	4	SLP-35EE2H	SLP-35EE2S1H
	35	22	0.5	8	8	7	120	20	20	4	SLP-35VE2H	SLP-35VE2S1H
1-1/2"	40	30	0.5	8	8	7	80	20	20	4	SLP-40E2H	SLP-40E2S1H
	40	30	0.5	8	8	-	120	20	20	4	SLP-40EE2H	SLP-40EE2S1H
	40	30	0.5	8	8	7	120	20	20	4	SLP-40VE2H	SLP-40VE2S1H
2"	50	48	0.5	8	8	7	80	20	20	4	SLP-50E2H	SLP-50E2S1H
	50	48	0.5	8	8	-	120	20	20	4	SLP-50EE2H	SLP-50EE2S1H
	50	48	0.5	8	8	7	120	20	20	4	SLP-50VE2H	SLP-50VE2S1H
Flange 4port	25	12	0.5	8	8	7	80	20	20	4	-	SLPFEE2-25LS1H
	25	12	0.5	8	8	-	120	20	20	4	-	SLPFEE2-25LS1H
	25	12	0.5	8	8	7	120	20	20	4	-	SLPFVE2-25LS1H
Flange 4port	35	22	0.5	8	8	7	80	20	20	4	-	SLPFEE2-35LS1H
	35	22	0.5	8	8	-	120	20	20	4	-	SLPFEE2-35LS1H
	35	22	0.5	8	8	7	120	20	20	4	-	SLPFVE2-35LS1H
Flange 4port	40	30	0.5	8	8	7	80	20	20	4	-	SLPFEE2-40LS1H
	40	30	0.5	8	8	-	120	20	20	4	-	SLPFEE2-40LS1H
	40	30	0.5	8	8	7	120	20	20	4	-	SLPFVE2-40LS1H
Flange 4port	50	48	0.5	8	8	7	80	20	20	4	-	SLPFEE2-50LS1H
	50	48	0.5	8	8	-	120	20	20	4	-	SLPFEE2-50LS1H
	50	48	0.5	8	8	7	120	20	20	4	-	SLPFVE2-50LS1H

## ZS Series 2/2 Solenoid Valve

### How to Order?

#### Order Example:

ZS series, 2 position, 2 port, AC 110V, 1/8" port size, Orifice: 3mm, Brass, Normal Close, NBR Seal, Model: ZS06E1-3L  
 ZS series, 2 position, 2 port, AC 220V, 3/8" port size, Orifice: 16mm, SS304, Normal Open, VITON Seal, Model: ZS10VE2-16LS2H  
 Note: 2.5mm only available flying leads coil, other orifice all with DIN connector

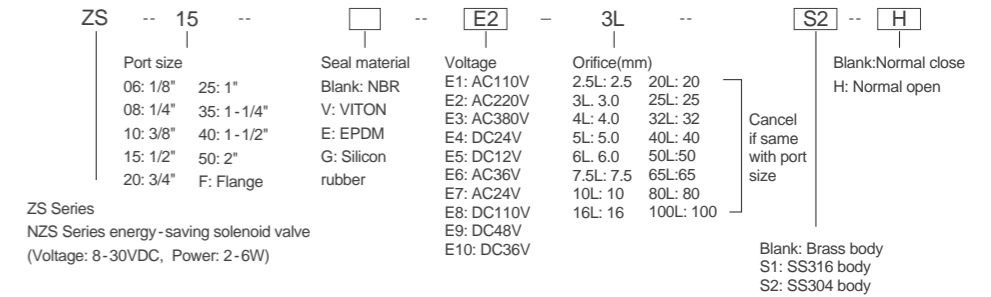

### ZS Solenoid Valve

- ZS06E2-2.5L
- ZS06E2-2.5LS2
- ZS10E2-16L
- ZS10E2-16LS2
- ZSF50S2

Up to 4"



### Specifications

Port Size	Orifice (mm)	CV Value	Min. Pressure	Pressure Difference (Bar)						Max. Temperature ( )	ZS			Model 220VAC 50/60HZ	
				Max. Working Pressure							VA	W	W	Brass	Stainless Steel 304
				Air / Gas	Water / Hot Water / Liquid		Light Oil	20CSTT	AC						
1/8"	2.5	0.23	0	7	5	7	5	7	5	80	13	8.5	-	ZS06E2-2.5L	ZS06E2-2.5LS2
	2.5	0.23	0	7	5	7	5	-	-	120	13	8.5	-	ZS06EE2-2.5L	ZS06EE2-2.5LS2
	2.5	0.23	0	7	5	7	5	7	5	120	13	8.5	-	ZS06VE2-2.5L	ZS06VE2-2.5LS2
1/4"	2.5	0.23	0	7	5	7	5	7	5	80	13	8.5	-	ZS08E2-2.5L	ZS08E2-2.5LS2
	2.5	0.23	0	7	5	7	5	-	-	120	13	8.5	-	ZS08EE2-2.5L	ZS08EE2-2.5LS2
	2.5	0.23	0	7	5	7	5	7	5	120	13	8.5	-	ZS08VE2-2.5L	ZS08VE2-2.5LS2
	10	1.0	0	20	16	20	16	20	16	80	22	13	2.6	ZS08E2-10L	-
	10	1.0	0	20	16	20	16	-	-	120	22	13	2.6	ZS08EE2-10L	-
10	1.0	0	20	16	20	16	20	16	120	22	13	2.6	ZS08VE2-10L	-	

Specifications

Port Size	Orifice (mm)	CV Value	Pressure Difference (Bar)							Max. Temperature (°C)	ZS			N/ZS		Modle 220VAC 50/60HZ	
			Min. Pressure	Max. Working Pressure				20CSTT	VA AC220		W DC24V	W DC24V	Brass		Stainless Steel 304		
				Air / Gas	Water / Hot Water / Liquid	Light Oil	AC						DC	AC		DC	
3/8"	4	0.6	0	8	5	8	5	5	5	80	20	20	4	ZS10E2-4L	ZS10E2-4LS2		
	4	0.6	0	8	5	8	5	-	-	120	20	20	4	ZS10EE2-4L	ZS10EE2-4LS2		
	4	0.6	0	8	5	8	5	5	5	120	20	20	4	ZS10VE2-4L	ZS10VE2-4LS2		
	10	1.8	0	20	16	20	16	20	16	80	22	13	2.6	ZS10E2-10L	-		
	10	1.8	0	20	16	20	16	-	-	120	22	13	2.6	ZS10EE2-10L	-		
	10	1.8	0	20	16	20	16	20	16	120	22	13	2.6	ZS10VE2-10L	-		
	16	4.8	0	10	6	10	6	7	4	80	20	20	4	ZS10E2-16L	ZS10E2-16LS2		
1/2"	16	4.8	0	10	6	10	6	-	-	120	20	20	4	ZS10EE2-16L	ZS10EE2-16LS2		
	16	4.8	0	10	6	10	6	7	4	120	20	20	4	ZS10VE2-16L	ZS10VE2-16LS2		
	10	1.9	0	20	16	20	16	20	16	80	22	13	2.6	ZS15E2-10L	-		
	10	1.9	0	20	16	20	16	-	-	120	22	13	2.6	ZS15EE2-10L	-		
	10	1.9	0	20	16	20	16	20	16	120	22	13	2.6	ZS15VE2-10L	-		
	16	4.8	0	10	6	10	6	7	4	80	20	20	4	ZS15E2-16L	ZS15E2-16LS2		
	16	4.8	0	10	6	10	6	-	-	120	20	20	4	ZS15EE2-16L	ZS15EE2-16LS2		
3/4"	16	4.8	0	10	6	10	6	7	4	120	20	20	4	ZS15VE2-16L	ZS15VE2-16LS2		
	20	7.6	0	10	6	10	6	7	4	80	20	20	4	ZS-20E2	ZS-20E2S2		
	20	7.6	0	10	6	10	6	-	-	120	20	20	4	ZS-20EE2	ZS-20EE2S2		
1"	20	7.6	0	10	6	10	6	7	4	120	20	20	4	ZS-20VE2	ZS-20VE2S2		
	25	12	0	10	6	10	6	7	4	80	20	20	4	ZS-25E2	ZS-25E2S2		
	25	12	0	10	6	10	6	-	-	120	20	20	4	ZS-25EE2	ZS-25EE2S2		
	25	12	0	10	6	10	6	7	4	120	20	20	4	ZS-25VE2	ZS-25VE2S2		
1-1/4"	25	12	0	-	-	3	3	-	-	120	20	20	4	ZS-25GE2	ZS-25GE2S2		
	32	24	0	10	6	10	6	7	4	80	33	45	-	ZS-35E2	ZS-35E2S2		
	32	24	0	10	6	10	-	-	-	120	33	45	-	ZS-35EE2	ZS-35EE2S2		
1-1/2"	32	24	0	10	6	10	6	7	4	120	33	45	-	ZS-35VE2	ZS-35VE2S2		
	40	29	0	10	6	10	6	7	4	80	33	45	-	ZS-40E2	ZS-40E2S2		
	40	29	0	10	6	10	-	-	-	120	33	45	-	ZS-40EE2	ZS-40EE2S2		
2"	40	29	0	10	6	10	6	7	7	120	33	45	-	ZS-40VE2	ZS-40VE2S2		
	50	48	0	10	6	10	6	7	4	80	33	45	-	ZS-50E2	ZS-50E2S2		
	50	48	0	10	6	10	-	-	-	120	33	45	-	ZS-50EE2	ZS-50EE2S2		
Flange 4 ports	50	48	0	10	6	10	6	7	4	120	33	45	-	ZS-50VE2	ZS-50VE2S2		
	25	12	0	10	6	10	6	7	4	80	33	45	-	-	ZSFE2-25LS2		
	25	12	0	10	6	10	-	-	-	120	33	45	-	-	ZSFEE2-25LS2		
	25	12	0	10	6	10	6	7	4	120	33	45	-	-	ZSFVE2-25LS2		
	32	24	0	10	6	10	6	7	4	80	33	45	-	-	ZSFE2-32LS2		
	32	24	0	10	6	10	-	-	-	120	33	45	-	-	ZSFEE2-32LS2		
	32	24	0	10	6	10	6	7	4	120	33	45	-	-	ZSFVE2-32LS2		
	40	29	0	10	6	10	6	7	4	80	33	45	-	-	ZSFE2-40LS2		
	40	29	0	10	6	10	-	-	-	120	33	45	-	-	ZSFEE2-40LS2		
	40	29	0	10	6	10	6	7	4	120	33	45	-	-	ZSFVE2-40LS2		
	50	48	0	10	6	10	6	7	4	80	33	45	-	-	ZSFE2-50LS2		
	50	48	0	10	6	10	-	-	-	120	33	45	-	-	ZSFEE2-50LS2		
	50	48	0	10	6	10	6	7	4	120	33	45	-	-	ZSFVE2-50LS2		
	65	75	0	6	5	6	5	3	2	80	55	64	-	-	ZSFE2-65LS2		
	65	75	0	6	5	6	5	-	-	120	55	64	-	-	ZSFEE2-65LS2		
	65	75	0	6	5	6	5	3	2	120	55	64	-	-	ZSFVE2-65LS2		
	80	90	0	6	5	6	5	3	2	80	55	64	-	-	ZSFE2-80LS2		
	80	90	0	6	5	6	5	-	-	120	55	64	-	-	ZSFEE2-80LS2		
	80	90	0	6	5	6	5	3	2	120	55	64	-	-	ZSFVE2-80LS2		
	100	160	0	6	5	6	5	3	2	80	55	64	-	-	ZSFE2-100LS2		
	100	160	0	6	5	6	5	-	-	120	55	64	-	-	ZSFEE2-100LS2		
	100	160	0	6	5	6	5	3	2	120	55	64	-	-	ZSFVE2-100LS2		

\* Orifice: 2.5mm, Only flying leads Coil

ZS-H 2/2 Solenoid Valve (Normal Open)

ZS-H 2/2 Solenoid Valve

- 1. ZS10E2-16LH
- 2. ZS15E2-16LS2H

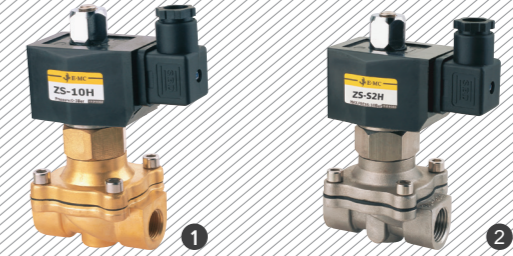

Specifications

Port Size	Orifice (mm)	CV Value	Pressure Difference (Bar)							Max. Temperature (°C)	ZS			N/ZS		Modle 220VAC 50/60HZ	
			Min. Pressure	Max. Working Pressure				20CSTT	VA AC220		W DC24V	W DC24V	Brass		Stainless Steel 304		
				Air / Gas	Water / Hot Water / Liquid	Light Oil	AC						DC	AC		DC	
3/8"	4.0	0.6	0	5	3	5	3	3	3	80	33	20	4	ZS10E2-4LH	ZS10E2-4LS2H		
	4.0	0.6	0	5	3	5	3	-	-	120	33	20	4	ZS10EE2-4LH	ZS10EE2-4LS2H		
	4.0	0.6	0	5	3	5	3	3	3	120	33	20	4	ZS10VE2-4LH	ZS10VE2-4LS2H		
	16	4.8	0	5	3	3	5	3	3	80	33	20	4	ZS10E2-16LH	ZS10E2-16LS2H		
	16	4.8	0	5	3	3	5	-	-	120	33	20	4	ZS10EE2-16LH	ZS10EE2-16LS2H		
1/2"	16	4.8	0	5	3	3	5	3	3	120	33	20	4	ZS10VE2-16LH	ZS10VE2-16LS2H		
	16	4.8	0	5	3	5	3	3	3	80	33	20	4	ZS15E2-16LH	ZS15E2-16LS2H		
	16	4.8	0	5	3	5	3	-	-	120	33	20	4	ZS15EE2-16LH	ZS15EE2-16LS2H		
3/4"	16	4.8	0	5	3	5	3	3	3	120	33	20	4	ZS15VE2-16LH	ZS15VE2-16LS2H		
	20	7.6	0	5	3	5	3	3	3	80	33	20	4	ZS-20E2H	ZS-20E2S2H		
	20	7.6	0	5	3	5	3	-	-	120	33	20	4	ZS-20EE2H	ZS-20EE2S2H		
1"	20	7.6	0	5	3	5	3	3	3	120	33	20	4	ZS-20VE2H	ZS-20VE2S2H		
	25	12	0	5	3	5	3	3	3	80	33	20	4	ZS-25E2H	ZS-25E2S2H		
	25	12	0	5	3	5	3	-	-	120	33	20	4	ZS-25EE2H	ZS-25EE2S2H		
	25	12	0	5	3	5	3	3	3	120	33	20	4	ZS-25VE2H	ZS-25VE2S2H		
	32	24	0	5	3	5	3	3	3	80	70	55	-	ZS35E2-32LH	ZS35E2-32LS2H		
1-1/4"	32	24	0	5	3	5	3	-	-	120	70	55	-	ZS35EE2-32LH	ZS35EE2-32LS2H		
	32	24	0	5	3	5	3	3	3	120	70	55	-	ZS35VE2-32LH	ZS35VE2-32LS2H		
	40	29	0	5	3	5	3	3	3	120	70	55	-	ZS-40E2H	ZS-40E2S2H		
1-1/2"	40	29	0	5	3	5	3	-	-	120	70	55	-	ZS-40EE2H	ZS-40EE2S2H		
	40	29	0	5	3	5	3	3	3	120	70	55	-	ZS-40VE2H	ZS-40VE2S2H		
	50	48	0	5	3	5	3	3	3	80	70	55	-	ZS-50E2H	ZS-50E2S2H		
2"	50	48	0	5	3	5	3	-	-	120	70	55	-	ZS-50EE2H	ZS-50EE2S2H		
	50	48	0	5	3	5	3	3	3	120	70	55	-	ZS-50VE2H	ZS-50VE2S2H		
	25	12	0	5	3	5	3	3	3	80	57	32	6	-	ZSFE2-25LS2H		
Flange 4 port	25	12	0	5	3	5	3	-	-	120	57	32	6	-	ZSFEE2-25LS2H		
	25	12	0	5	3	5	3	3									

## ESP Series 2/2 Solenoid Valve (Normal Close)

ESP Series Solenoid Valve

ESP-10

Available with both N.O and N.C,  
3/8"~1-1/4"



### How to Order?

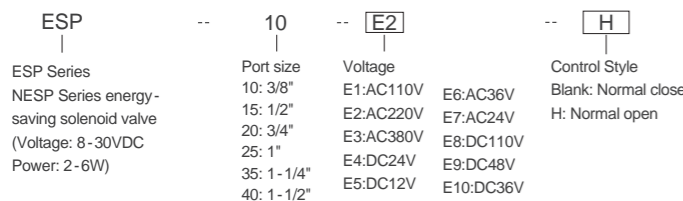

### Order Example:

ESP series, 2 position,2 port,AC110V, 3/8" port size, Normal Close ,  
Model : ESP10E1

### Specifications

Model	ESP10	ESP15	ESP20	ESP25	ESP35	ESP40
	NESP10	NESP15	NESP20	NESP25	NESP35	NESP40
Working Medium	Air, Gas ,Water ,Liquid					
Working Temperature( )	0~65					
Working Type	Diaphragm					
Orifice(mm)	15	15	25	25	40	40
Joint Size	3/8"	1/2"	3/4"	1"	1-1/4"	1-1/2"
Working Pressure(Bar)	0.5~7					
Max. Pressure(Bar)	9					
Valve Body	Reinforce Nylon					

## ZSP Series Solenoid Valve (Normal Close)

ZSP Series Solenoid Valve

ZSP-15



### How to Order?

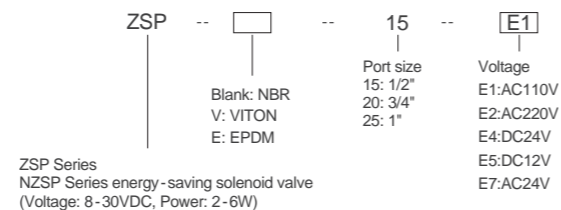

### Order Example:

ZSP series, 2 position,2 port, NBR seal,AC 110V, 1/2" port size, Model: ZSP15E1

### Specifications

Model	ZSP15	ZSP20	ZSP25
	NZSP15	NZSP20	NZSP25
Working Medium	Air, Gas ,Water ,Liquid		
Working Temperature( )	-5~80		
Working Type	Diaphragm		
Orifice(mm)	16	20	25
Joint Size	1/2"	3/4"	1"
Working Pressure(Bar)	AC: 0~8 DC: 0~6		
Max. Pressure(Bar)	12		
Valve Body	PA6		
Seal Material	NBR (EPDM, VITON is optional)		

## UD Series 2/2 Solenoid Valve (Normal Close)

UD Series Solenoid Valve

UD-06

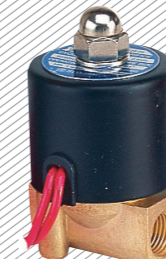

### How to Order?

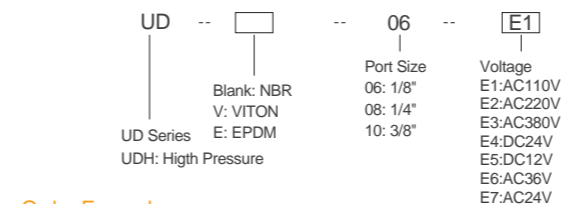

### Order Example:

UD series, 2 position,2 port, NBR seal,1/4" port size,orifice 2.5,Voltage : AC 220V, Model : UD08E2  
UDH High Pressure,2 position,2 port, NBR seal,1/4" port size,orifice1.2mm,Voltage:AC 220V, Model : UDH08E2

### Specifications

Bore size(mm)	UD06E2	UD08E2	UD10E2	UDH06E2	UDH08E2	UDH10E2
Working Medium	Air, Water, Oil, Gas					
Acting Type	Direct acting					
Type	Normal Close Type					
Orifice(mm)	2.5	4		1.2		2
Cv Value	0.23	0.6		0.05		0.15
Port Size	1/8"	1/4"	3/8"	1/8"	1/4"	3/8"
Fluid Viscosity	20 CST (Below)					
Working Pressure(Bar)	0~7			0~20		
Max. Pressure Resistance(Bar)	10			35		
Working Temperature ( )	-5~80					
Voltage Range	± 10%					
Valve Body Material	Brass					
Seal Material	NBR, VITON (optional)					

## UW Series 2/2 Solenoid Valve (Normal Close)

UW Series Solenoid Valve

UW-15

3/8"~2"

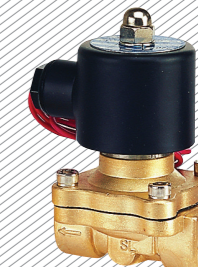

### How to Order?

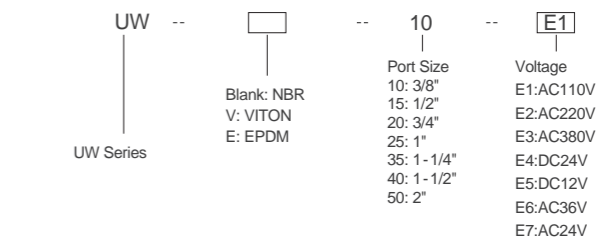

### Order Example:

UW series, 2 position,2 port, NBR seal,1/2" port size,Voltage AC220V,Model : UW15E2

### Specifications

Bore size(mm)	UW10E2	UW15E2	UW20E2	UW25E2	UW35E2	UW40E2	UW50E2
Orifice(mm)	16	16	20	25	35	40	50
Cv value	4.8	4.8	7.6	12	24	29	48
Port size	3/8"	1/2"	3/4"	1"	1-1/4"	1-1/2"	2"
Fluid viscosity	20 CST below						
Working pressure(Bar)	Air: 0~7, Water: 0~5, Oil: 0~5, Gas: 0~7						
Max pressure resistance(Bar)	11						
Working Temperature( )	-5~80						
Voltage Range	± 10%						
Protection Class	IP65						
Power Consumption	AC:7V/60Hz, 9V/50Hz, DC:6W						
Insulation Class	Class F						
Valve Body Material	Brass						
Seal Material	NBR, VITON (optional)						



## UWS Series 2/2 Solenoid Valve (Normal Close)

UWS Series Solenoid Valve

UWS-06E2

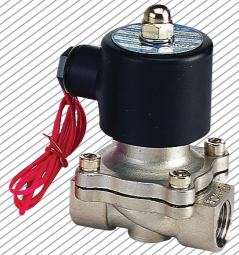

### How to Order?

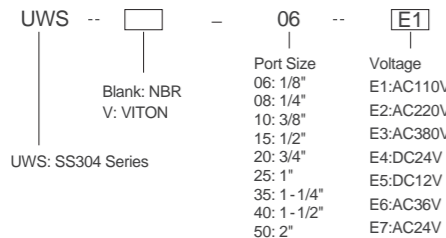

### Order Example:

UWS SS304 series, 2 position, 2 port, NBR seal, 1/2" port size, Voltage: AC 220V, Model: UWS-15E2

### Specifications

Model	UWS 06E2	UWS 08E2	UWS 10E2	UWS 10BE2	UWS 15E2	UWS 20E2	UWS 25E2	UWS 35E2	UWS 40E2	UWS 50E2
Working Medium	2.5	2.5	4	16	16	20	25	35	40	50
Cv value	0.23	0.23	0.6	4.8	4.8	7.6	12	24	29	48
Port size	1/8"	1/4"	3/8"	3/8"	1/2"	3/4"	1"	1-1/4"	1-1/2"	2"
Fluid Viscosity	20 CST (Below)									
Working pressure(Bar)	Water: 0-5, Air: 0-7, Oil: 0-5, Gas: 0-7									
Max. pressure resistance(Bar)	10.5									
Working temperature ( )	-5-80									
Voltage range	± 10%									
Valve Body Material	Stainless steel 304									
Seal Material	NBR, VITON (optional)									

## 2V Series Solenoid Valve (Normal Close)

2V Series Solenoid Valve

1.2V025-08E2  
2.2V130-15E2

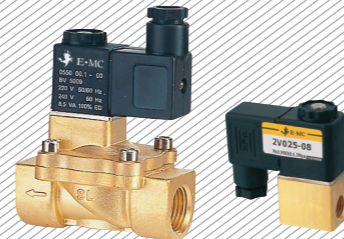

### How to Order?

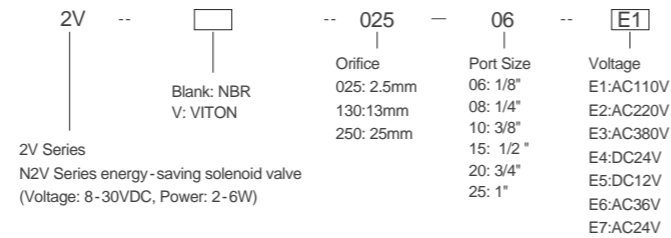

### Order Example:

2V series, 2 position, 2 port, NBR seal, 1/4" port size, orifice 2.5mm, Voltage AC220V, Model: 2V025-08E2

### Specifications

Bore size(mm)	2V025-06	2V025-08	2V130-10	2V130-15	2V250-20	2V250-25
	N2V025-06	N2V025-08	N2V130-10	N2V130-15	N2V250-20	N2V250-25
Working medium	Air, water, steam					
Acting type	Direct acting			Pilot		
Type	Normal close					
Orifice(mm)	2.5		13		25	
Cv value	0.23		4.5		12	
Port size	1/8	1/4	3/8	1/2	3/4	1
Fluid viscosity	20 CST below					
Working pressure(Bar)	Air/water/oil: 0-8			Air/water/oil: 0.5-7		
Max Pressure resistance(Bar)	12			11		
Working Temperature( )	-5-80					
Voltage Range	± 10%					
Protection Class	IP65					
Power Consumption	AC:7VA/60Hz, 9VA/50Hz, DC:6W					
Insulation Class	Class F					
Valve Body Material	Brass					
Seal Material	NBR or VITON			NBR		
Shortest Response Time	0.05s/second					

## PU 2/2 Solenoid Valve (Normal Close)

### How to Order?

#### Order example:

PU220 series, 2 position, 2 port, NBR seal, 3/8" port size, small orifice, Voltage: AC 220V, Model: PU220-03E2S

PU220 series, 2 position, 2 port, NBR seal, 1/2" port size, with Timer, Voltage: DC 24V, Model: PU220-04E4T

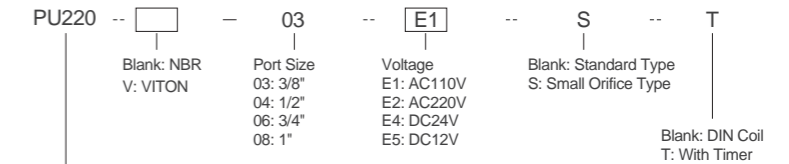

PU220 Series  
NPU220 Series energy-saving solenoid valve  
(Voltage: 8-30VDC, Power: 2-6W)

### PU2/2 Solenoid Valve (Normal Close)

1. PU220E4-03S
2. PUT220E2-06

Automatic draining, 3/8"~1"



### Specifications

Model	PU220E4-03S	PU220E4-04S	PU220E4-03	PUT220E4-04	PUT220E4-06	PUT220E4-08
	PUT220E4-03S	PUT220E4-04S	PUT220E4-03	PUT220E4-04	PUT220E4-06	PUT220E4-08
	NPU220E4-03S	NPU220E4-04S	NPU220E4-03	NPUT220E4-04	NPUT220E4-06	NPUT220E4-08
Working Medium	Air, water, oil					
Orifice(mm)	8.0	8.0	13	13	20	25
Cv Value	1.00	1.00	4.00	4.00	8.60	11.00
Port Size	3/8"	1/2"	3/8"	1/2"	3/4"	1"
Fluid Viscosity	20 CST					
Working Pressure(Bar)	0-7					
Max. Pressure Resistance(Bar)	11					
Working Temperature( )	-5-80					
Voltage Range	± 10%					
Seal Material	NBR					

## VX2120 Series 2/2 Solenoid Valve (Normal Close)

VX Series Solenoid Valve

VX2120

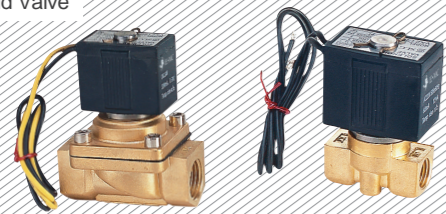

### How to Order?

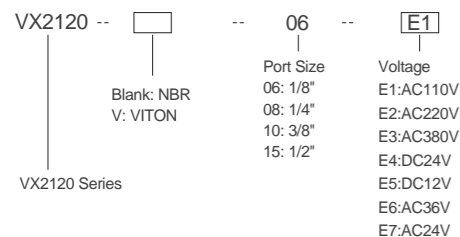

**Order Example:**  
VX2120 series, 2 position,2 port, NBR seal,1/2"port size,voltage AC220V,Model : VX2120-15E2

### Specifications

Model	VX2120-06E2	VX2120-08E2	VX2120-10E2	VX2120-15E2
Working Medium	Air, Water, Steam			
Acting Type	Direct Drive			
Type	Normal Close			
Working pressure(Bar)	0~10			
Orifice(mm)	3	10	13	
Port Size	1/8"	1/4"	3/8"	1/2"
Working Temperature( )	-5~80(150 is optional)			
Seal Material	NBR(VITON is optional)			

## 2P Series 2/2 Solenoid Valve (Normal Close)

2P Series Solenoid Valve

2P025-06E2F



### How to Order?

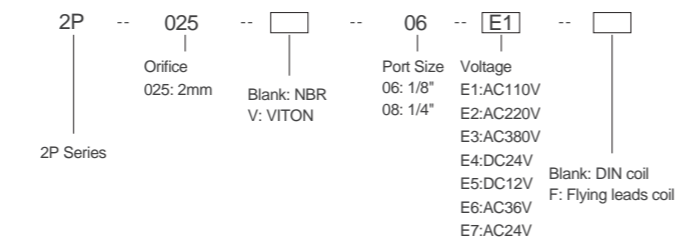

**Order Example:**  
2P series, 2 position,2 port, NBR seal,1/4" port size,Voltage AC220V,DIN coil, Model : 2P025-08E2

### Specifications

Bore size(mm)	2P025-06E2	2P025-08E2
Working Medium	Air, Water, Oil, Steam	
Acting Type	Direct acting	
Type	Normal Close Type	
Orifice(mm)	2.5	
Cv Value	0.23	
Port Size	1/8"	1/4"
Fluid Viscosity	20 CST (Below)	
Working Pressure(Bar)	0~7	
Max Pressure Resistance(Bar)	11	
Working Temperature( )	-5~80	
Voltage Range	+10%	
Power Consumption	AC:7VA/50Hz, 9VA/50Hz, DC:6W	
Valve Body Material	Engineering Plastic	
Seal Material	NBR, VITON (optional)	

## EWSLC Series 2/2 Direct Acting Solenoid Valve(Normal Close)

EWSLC Series Solenoid Valve

1.EWSLC1  
2.EWSLC2



### How to Order?

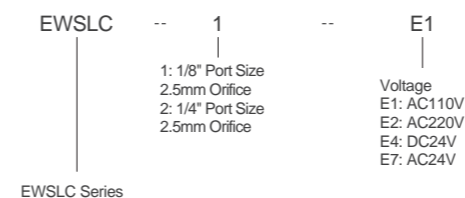

**Order Example:**  
EWSLC1 series,1/8" port size,orifice:2.5mm, AC220V,Model:EWSLC1E2

### Specifications

Model	EWSLC1E2	EWSLC2E2
Working Medium	Water	
Acting Type	Direct Acting	
Type	2/2 Normal Close	
Orifice	2.5(3/32)	
Cv Value	0.21	
Port Size	1/8"	1/4"
Working Pressure(Bar)	0~8	
Working Temperature( )	0~100	
Ambient Temperature( )	-10~40	
Seal Material	EPDM	
Valve Body	PP 1/8(Black) 1/4(White) Nylon66	

## EWSLC Series 2/2 Direct Acting Solenoid Valve (Normal Close)

EWSLC Series Solenoid Valve

1.EWSLC3  
2.EWSLC4



### How to Order?

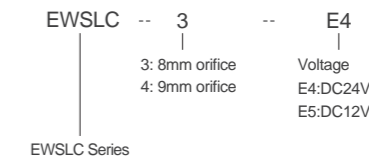

**Order Example:**  
EWSLC series,orifice:8mm,DC24V,Model : EWSLC3E4

### Specifications

Model	EWSLC3E4	EWSLC4E4
Working Medium	Water	
Acting Type	Direct Acting	
Type	2/2 Normal Close	
Orifice	8	9
Port Size	12	
Working Pressure(Bar)	0~0.6	
Working Temperature( )	0~100	
Ambient Temperature( )	-10~40	
Seal Material	Silicon rubber	
Valve Body	PP	

## EDF Series 2/2 Solenoid Valve (Normal Close)

### How to Order?

#### Order Example:

EDF series, Brass Valve Body, 2 position, 2 port, Port size: 1/2", voltage: AC220V, Model: EDF15E2

EDFS series, Stainless Steel Valve Body, 2 position, 2 port, Port size: 1-1/4", voltage: DC24V, Model: EDFS35E4

EDF	--	15	--	E2
EDF: Brass Valve Body EDFS: Stainless Steel Valve Body	Port size	15: 1/2" 20: 3/4" 25: 1" 35: 1-1/4" 40: 1-1/2" 50: 2"	Voltage	E2: AC220V E4: DC24V
	65F: Flange 4 holes,	17.5 orifice,	145 hole distance	
	80F: Flange 4 holes,	17.5 orifice,	160 hole distance	
	100F: Flange 8 holes,	17.5 orifice,	180 hole distance	
	150F: Flange 8 holes,	22 orifice,	240 hole distance	

### EDF Series Solenoid Valve

1. EDF
2. EDFS

Especially for music fountain,  
1/2"~6"

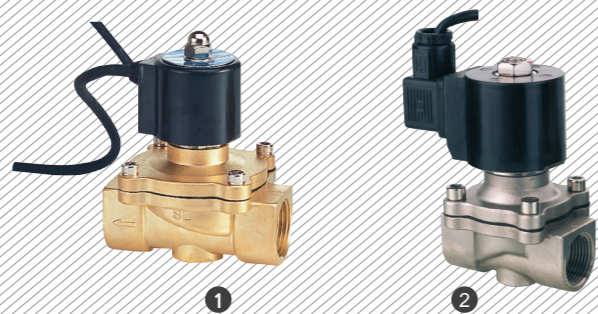

### Specifications

Model	EDF15E2	EDF20E2	EDF25E2	EDF35E2	EDF40E2	EDF50E2
	EDF65FE2	EDF80FE2	EDF100FE2	EDF125FE2	EDF150FE2	
	EDFS15E2	EDFS20E2	EDFS25E2	EDFS35E2	EDFS40E2	EDFS50E2
Working Medium	Water					
Working Pressure(Bar)	50(0~6)		65(0.6~5)			
Voltage Range	± 10%					
Ambient Temperature( )	-10~50					
Working Temperature ( )	0~60					
Power Consumption	Over 25, below 65	AC220V 28VA, DC24V 33W;		32 40	50 AC220V 35VA, DC24V 40W	
Insulation	Class B					
Lifetime	20 Thousand times					
Respond time	0.2 Sec.					
Installation	Direction of the fluid is Following the arrow					

## SLG5404 Series 2/2 Solenoid Valve (Normal Close)

### SLG5404 Series Solenoid Valve

SLG5404-15  
SLG5404-20E2D

50 Bar, 1/2"~1"

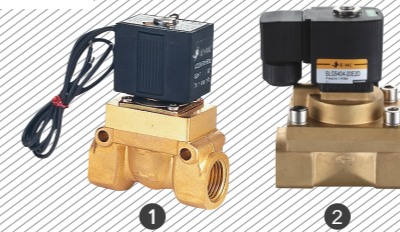

### How to Order?

SLG5404	--	15	--	E1	--	D
SLG5404 Series NSLG5404 Series energy-saving solenoid valve (Voltage: 8-30VDC, Power: 2-6W)	Port Size	15: 1/2" 20: 3/4" 25: 1"	Voltage	E1: AC110V E2: AC220V E3: AC380V E4: DC24V E5: DC12V E7: AC24V	Blank: Flying leads Type D: DIN Connector	

#### Order Example:

SLG5404 series, 1/2 port, flying leads coil, voltage: AC220V, Model: SLG5404-15E2

### Specifications

Model	SLG5404-15E2	SLG5404-20E2	SLG5404-25E2
	NSLG5404-15E2	NSLG5404-20E2	NSLG5404-25E2
Working Medium	Air, Water, Oil		
Acting Type	Pilot Type		
Orifice(mm)	12	20	25
Cv Value	2	5	10
Port Size	1/2"	3/4"	1"
Working Pressure(Bar)	GAS:1~50, Liquid:1~50		GAS:1~40, Liquid:1~25
Max. Pressure Resistance(Bar)	70		60
Working Temperature( )	-10~150		
Power Consumption	AC:5.5VA, DC:9W		
Valve Body Material	Brass		
Seal Material	PTFE		

## EAT22 Series Solenoid Valve (High frequency valve)

### EAT22 Series Solenoid Valve

EAT22-10-8L

New Technology  
37 cycles per second  
1.1 billion cycles lifetime  
DC-ON:48V, DC-HOLD:8V

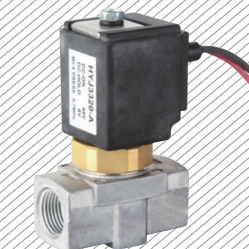

### How to Order?

EAT22	--	10	--	E1	--	3L
EAT22 Series	Port Size	10: 3/8"	Voltage	E1: DC24V	Orifice(mm)	8L= 8.0

#### Product features:

Two way two position solenoid valve  
High frequency valve  
Long lifetime with 1.1 billion cycles  
Stable quality, guarantee two years

### Specifications

Port Size	Orifice (mm)	Pressure Difference (Bar)		Working temperature	Resistance	Insulation class	Weight	Main dimensions
		Min.	Max. (air, inet gas)					
3/8"	8	0	7	5~40	31 ± 2	class B	300g	50*30*75.1

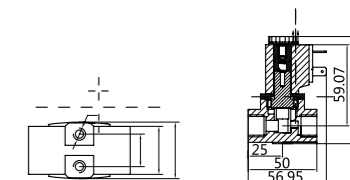

## THP Series 2/2 Solenoid Valve (Normal Close)

### How to Order?

#### Order Example:

THP series, 2 position, 2 port, AC 110V, 1/8" port size, Orifice : 2.5mm, Brass, Normal Close, NBR seal, DIN Coil, Model : THP06E1-2.5L  
 THP series, 2 position, 2 port, AC 110V, 3/8" port size, Orifice : 15mm, SS304, Normal Open, Teflon seal, Flying Leads Coil, Model : THP10TE1-15LS2HF

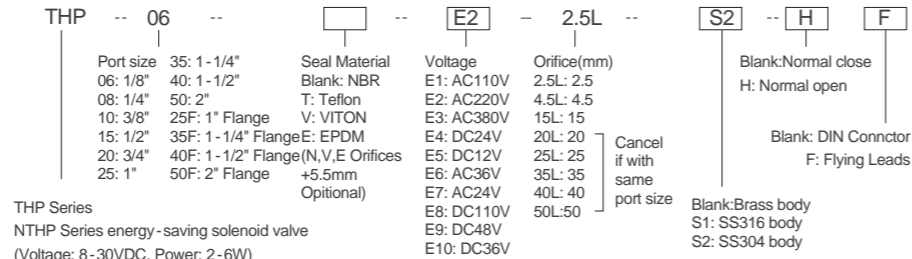

THP Series 2/2 Solenoid Valve (Normal Close)

1. THP - 15TE2
2. THP - 15TE2S2

185 , for steam, 1/8"~2"

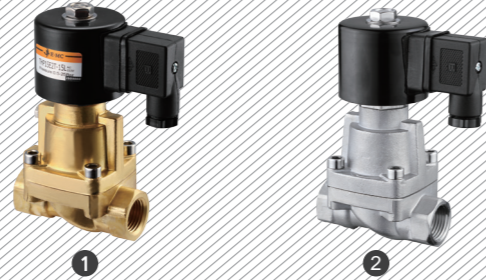

### Specifications

Port Size	Orifice (mm)	CV Value	Min. Pressure	Pressure Difference (Bar)							Max. Temperature (°C)	THP			Model	
				Max. Working Pressure								VA	W	W	Brass	Stainless Steel
				AC	DC	AC	DC	Light Oil	20CSTT	Steam						
1/8"	2.5	0.23	0	8	8	8	8	6	6	10	180	22	13	2.6	THP06TE2-2.5L	-
	2.5	0.23	0	13	13	13	13	7	7	10	110	22	13	2.6	THP06VE2-2.5L	-
	4.5	0.6	0	7	4	7	4	4	4	7	165	22	13	2.6	THP06E2-2.5L	-
	4.5	0.6	0	7	4	7	4	4	4	7	80	22	13	2.6	THP06E2-2.5L	-
1/4"	2.5	0.23	0	7	4	7	4	4	4	7	165	22	13	2.6	THP06TE2-4.5L	-
	2.5	0.23	0	13	13	13	13	7	7	7	110	22	13	2.6	THP06VE2-4.5L	-
	4.5	0.6	0	7	4	7	4	4	4	3	165	22	13	2.6	THP06E2-4.5L	-
3/8"	4.5	0.6	0	7	4	7	4	4	4	7	80	22	13	2.6	THP06E2-4.5L	-
	15	4.5	0.5	25	20	25	20	20	20	10	180	22	13	2.6	THP08TE2-2.5L	-
	15	4.5	0.5	25	20	25	20	20	20	10	110	22	13	2.6	THP08VE2-2.5L	-
1/2"	15	4.5	0.5	25	20	25	20	20	20	10	110	33	32	6	THP10VE2-15L	THP10VE2-15LS2
	15	4.5	0.5	25	20	25	20	20	20	10	185	30	25	5	THP10TE2-15LF	THP10TE2-15LS2F

## THP Series 2/2 Solenoid Valve (Normal Close)

### Specifications

Port Size	Orifice (mm)	CV Value	Min. Pressure	Pressure Difference (Bar)							Max. Temperature (°C)	THP			Model	
				Max. Working Pressure								VA	W	W	Brass	Stainless Steel
				AC	DC	AC	DC	Light Oil	20CSTT	Steam						
3/4"	20	9.0	0.5	25	20	25	20	20	20	10	110	33	32	6	THP20VE2	THP-20VE2S2
	20	9.0	0.5	25	20	25	20	20	20	10	185	30	25	5	THP20TE2F	THP-20TE2S2F
1"	25	13	0.5	25	20	25	20	20	20	10	110	33	32	6	THP25VE2	THP-25VE2S2
	25	13	0.5	25	20	25	20	20	20	10	185	30	25	5	THP25TE2F	THP-25TE2S2F
1-1/4"	35	26	0.5	25	20	25	20	20	20	10	110	33	32	6	THP35VE2	THP-35VE2S2
	35	26	0.5	25	20	25	20	20	20	10	185	30	25	5	THP35TE2F	THP-35TE2S2F
1-1/2"	35	26	0.5	25	20	25	20	20	20	10	110	33	32	6	THP40VE2-35L	THP-40VE2-35LS2
	35	26	0.5	25	20	25	20	20	20	10	185	30	25	5	THP40TE2-35LF	THP-40TE2-35LS2F
2"	50	48	0.5	25	20	25	20	20	20	10	110	33	32	6	-	THP-50VE2S2
	50	48	0.5	25	20	25	20	20	20	10	185	30	25	5	-	THP-50TE2S2F
1" flange	25	13	0.5	25	20	25	20	20	20	10	110	33	32	6	-	THPFVE2-25LS2
	25	13	0.5	25	20	25	20	20	20	10	185	30	25	5	-	THPFTE2-25LS2F
1-1/4" flange	35	26	0.5	25	20	25	20	20	20	10	110	33	32	6	-	THPFVE2-35LS2
	35	26	0.5	25	20	25	20	20	20	10	185	30	25	5	-	THPFTE2-35LS2F
1-1/2" flange	35	26	0.5	25	20	25	20	20	20	10	110	33	32	6	-	THPFVE2-40LS2
	35	26	0.5	25	20	25	20	20	20	10	185	30	25	5	-	THPFTE2-40LS2F
2" flange	50	45	0.5	25	20	25	20	20	20	10	110	33	32	6	-	THPFVE2-50LS2
	50	45	0.5	25	20	25	20	20	20	10	185	30	25	5	-	THPFTE2-50LS2F
1-1/4"	35	26	0.5	25	20	25	20	20	20	10	110	33	32	6	THP35VE2	THP35VE2VS2
	35	26	0.5	25	20	25	20	20	20	10	185	30	25	5	THP35TE2	THP35TE2S2F
1-1/2"	35	26	0.5	25	20	25	20	20	20	10	110	33	32	6	THP40VE2-35L	THP40VE2-35LS2
	35	26	0.5	25	20	25	20	20	20	10	185	30	25	5	THP40TE2-35LF	THP40TE2-35LS2F
2"	50	48	0.5	25	20	25	20	20	20	10	110	33	32	6	-	THP50VE2S2
	50	48	0.5	25	20	25	20	20	20	10	185	30	25	5	-	THP50TE2S2F
1" flange	25	13	0.5	25	20	25	20	20	20	10	110	33	32	6	-	THP25FVE2S2
	25	13	0.5	25	20	25	20	20	20	10	185	30	25	5	-	THP25FTE2S2F
1-1/4" flange	35	26	0.5	25	20	25	20	20	20	10	110	33	32	6	-	THP35FVE2S2
	35	26	0.5	25	20	25	20	20	20	10	185	30	25	5	-	THP35FTE2S2F
1-1/2" flange	35	26	0.5	25	20	25	20	20	20	10	110	33	32	6	-	THP40FVE2-35LS2
	35	26	0.5	25	20	25	20	20	20	10	185	30	25	5	-	THP40FTE2-35LS2F
2" flange	50	45	0.5	25	20	25	20	20	20	10	110	33	32	6	-	THP-50FVE2S2
	50	45	0.5	25	20	25	20	20	20	10	185	30	25	5	-	THP-50FTE2S2F

## THP-H Series 2/2 Solenoid Valve (Normal Open)

THP-H Series 2/2 Solenoid Valve

1. THP15TE2H
2. THP15TE2S2H

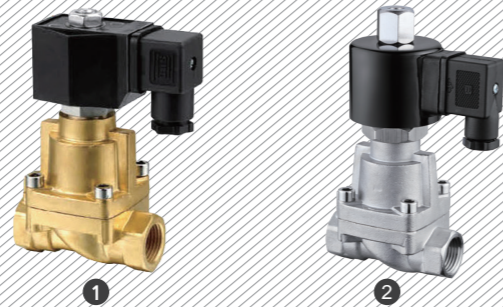

### Specifications

Port Size	Orifice (mm)	CV Value	Pressure Difference (Bar)					Max. Temperature (°C)	THP			NTHP		Model 220VAC 50/60HZ	
			Min. Pressure	Max. Working Pressure					VA	W	W	Brass		Stainless Steel	
				Air / Gas	Water / Hot Water / Liquid	Oil	Light Oil 20CST					Steam			
3/8"	15	4.5	0.5	8	8	8	8	130	33	13	6	THP10TE2-15LH	THP10TE2-15LS2H		
	15	4.5	0.5	8	8	8	8	130	33	13	6	THP10VE2-15LH	THP10TE2-15LS2HF		
1/2"	15	4.5	0.5	8	8	8	8	130	33	32	6	THP15TE2H	THP-15TE2S2H		
	15	4.5	0.5	8	8	8	8	130	33	32	6	THP15TE2HF	THP-15TE2S2HF		
3/4"	20	9.0	0.5	8	8	8	8	130	33	32	6	THP20TE2H	THP-20TE2S2		
	20	9.0	0.5	8	8	8	8	130	33	32	6	THP20TE2HF	THP-20TE2S2F		
1"	25	13	0.5	8	8	8	8	130	33	32	6	THP25TE2H	THP-25TE2S2		
	25	13	0.5	8	8	8	8	130	33	32	6	THP25TE2HF	THP-25TE2S2F		
1-1/4"	35	26	0.5	6	6	6	6	130	33	32	6	THP35TE2H	THP-35TE2S2		
	35	26	0.5	6	6	6	6	130	33	32	6	THP35TE2HF	THP-35TE2S2F		
1-1/2"	35	26	0.5	6	6	6	6	130	33	32	6	THP40TE2-35LH	THP40TE2-35LS2		
	35	26	0.5	6	6	6	6	130	33	32	6	THP40TE2-35LHF	THP40TE2-35LS2F		
1" flange	25	13	0.5	8	8	8	8	130	33	32	6	-	THP-25FTE2S2H		
	25	13	0.5	8	8	8	8	130	33	32	6	-	THP-25FTE2S2HF		
1-1/4" flange	35	26	0.5	6	6	6	6	130	33	32	6	-	THP-35FTE2S2H		
	35	26	0.5	6	6	6	6	130	33	32	6	-	THP-35FTE2S2HF		
1-1/2" flange	35	26	0.5	6	6	6	6	130	33	32	6	-	THP-40FTE2S2H		
	35	26	0.5	6	6	6	6	130	33	32	6	-	THP-40FTE2S2HF		
2" flange	50	48	0.5	6	6	6	6	130	33	32	6	-	THP-50FTE2S2H		
	50	48	0.5	6	6	6	6	130	33	32	6	-	THP-50FTE2S2HF		

## US Series 2/2 High-Temperature Solenoid Valve (Normal Close)

US Series Solenoid Valve

US-15E2

180 , for steam, 3/8"-2"

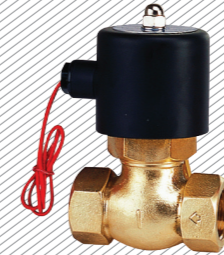

### How to Order?

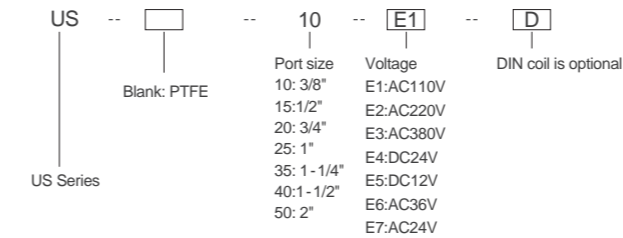

### Order Example:

US series, 2 position, 2 port, PTFE, 3/8" port size, AC220V, Model: US10E2

### Specifications

Model	US10E2	US15E2	US20E2	US25E2	US35E2	US40E2	US50E2
Working Medium	Air, Water, Steam						
Acting Type	Pilot Type						
Type	Normal Close Type						
Orifice (mm)	17		22		30		50
Cv Value	5		12		20		48
Port Size	3/8"	1/2"	3/4"	1"	1-1/4"	1-1/2"	2"
Fluid Viscosity	Below 20 CST						
Working Pressure (Bar)	1~15						
Max. Pressure Resistance (Bar)	23						
Working Temperature (°C)	-5~180						
Voltage Range	+10%						
Valve Body Material	Brass						
Seal Material	PTFE						

## HUS Stainless Steel Series Steam Solenoid Valve (Normal Close)

HUS Solenoid Valve

HUS-40FS2

250 , for steam, 3/8"-2"



### How to Order?

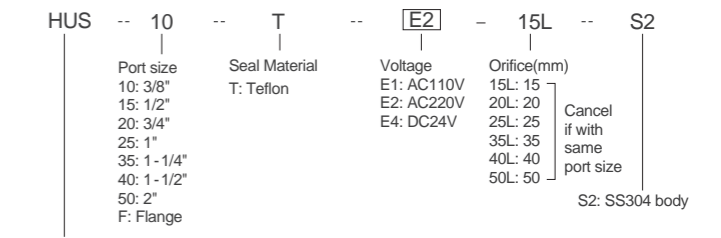

HUS SS316 Series

### Order Example:

HUS SS316 series, 2 position, 2 port, AC110V, 3/8" port size, Orifice: 15mm, Stainless Steel 304, Normal Close, Teflon Seal, Model: HUS10TE1-15LS2

### Specifications

\* With Voltage AC220V

Port Size	Orifice (mm)	CV Value	Pressure Difference (Bar)			Max. Temperature (°C)	Model 220VAC 50/60HZ
			Min. Pressure	Max. Working Pressure	Oil		
3/8"	15	4.5	0.5	16	16	250	HUS10TE2-15LS2
1/2"	15	4.5	0.5	16	16	250	HUS-15TE2S2
3/4"	20	8	0.5	16	16	250	HUS-20TE2S2
1"	25	12	0.5	16	16	250	HUS-25TE2S2
1-1/4"	35	22	0.5	16	16	250	HUS-35TE2S2
1-1/2"	35	22	0.5	16	16	250	HUS40TE2-35LS2
2"	50	45	0.5	16	16	250	HUS-50TE2S2
Flange 4 Port	25	12	0.5	16	16	250	HUSFTE2-25LS2
	32	22	0.5	16	16	250	HUSFTE2-32LS2
	40	22	0.5	16	16	250	HUSFTE2-40LS2
	50	45	0.5	16	16	250	HUSFTE2-50LS2

## EMC Series Full Stainless Steel Angle Solenoid Valve



EMC	--	10	-	40	--	A
		Port Size		Actuator Size		Type
		10: 3/8"		40: 40mm		A: Single Acting Normal Close
		15: 1/2"		50: 50mm		B: Single Acting Normal Open
		20: 3/4"		63: 63mm		C: Double Acting Normal Close
		25: 1"		80: 80mm		D: Double Acting Free Installation
		35: 1-1/4"		100: 100mm		
		40: 1-1/2"				
		50: 2"				

EMC Stainless Steel Series Angle Valve

### How to Order?

Order Example:  
EMC Stainless Steel series, 3/8" port size, Actuator Size 40mm, Single Acting Normal Close, Model: EMC10-40A

### Specifications

Model	EMC10-50A/B/C/D	Model	EMC10-50A/B/C/D
Port size	DN10-DN50	Working temperature( )	PTFE: -10~+180
Thread	G3/8"-G2"	Ambient temperature( )	-10~+60
Valve body	CF8M	Viscosity(mm <sup>2</sup> /s)	Max600
Actuator	CF8	Installation	Any position
Spool seal	PTFE	Controlling medium	Air, neutral gas
Piston seal	PTFE/FKM	Controlling pressure(Bar)	3~10
Medium	Water, neutral gas or liquid, ethanol, oil, organic solvent, steam, alkaline and weak acid solution		

Port Size	Orifice	Actuator	Kv Value	Working Pressure	Normal Close		Normal Open		Model	
					Admitted Differential Pressure Range	Control Pressure Range	Admitted Differential Pressure Range	Control Pressure Range	Normal Close	Normal Open
G3/8"	13	40	4.7	16	0-16	4	-	-	EMC10-40A	EMC10-40B
G3/8"	13	50	4.7	16	0-16	3	0-16	3	EMC10-50A	EMC10-50B
G1/2"	13	40	4.7	16	0-16	4	-	-	EMC15-40A	EMC15-40B
G1/2"	13	50	4.7	16	0-16	4	0-16	3	EMC15-50A	EMC15-50B
G3/4"	18	50	9.5	16	0-16	3-4	0-16	3	EMC20-50A	EMC20-50B
G1"	24	50	18.1	16	0-16	3-5.5	-	-	EMC25-50A	EMC25-50B
G1"	24	63	18.1	16	0-16	3-3.5	0-16	3.5	EMC25-63A	EMC25-63B
G1-1/4"	31	63	23.1	16	0-16	3-5	0-14	3.9	EMC35-63A	EMC35-63B
G1-1/2"	35	63	32.9	16	0-10	3-6	0-11	3.9	EMC40-63A	EMC40-63B
G2"	45	63	52.8	16	0-16	3-6.5	0-6	3.9	EMC50-63A	EMC50-63B
G2"	45	80	52.8	16	0-16	3-6.6	0-12	4	EMC50-80A	EMC50-80B

## EMC Series Full Stainless Steel Angle Solenoid Valve

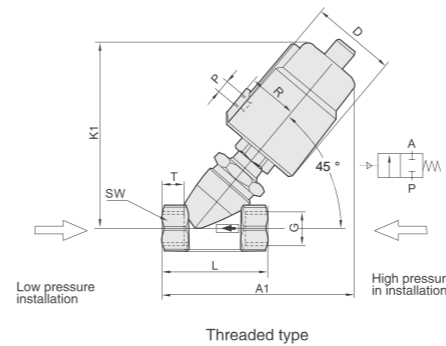

Type	Actuator	D	R	P	Thread					
					G	K1	A1	L	T	SW
DN10	40	50.5	27	G1/8"	G3/8"	108	133.5	74	10	22
	50	62	34	G1/8"	G3/8"	120	145.5	74	10	22
DN15	40	50	28	G1/8"	G1/2"	108	133.5	74	11.5	25
	50	62	35	G1/8"	G1/2"	120	145.5	74	11.5	25
DN20	50	62	35	G1/8"	G3/4"	124	153	84	14	31
	50	62	34	G1/8"	G1"	130	163.5	100	15	39
DN25	63	77	41.5	G1/8"	G1"	152	185.5	100	15	39
	63	77	41.5	G1/8"	G1-1/4"	160	196	112	18	48
DN35	80	98	52	G1/4"	G1-1/4"	177	213	112	18	48
	63	77	41.5	G1/8"	G1-1/2"	168	209	126	18	55
DN40	80	98	52	G1/4"	G1-1/2"	185	226	126	18	55
	100	121	63	G1/4"	G1-1/2"	203	244	126	18	55
DN50	63	77	43	G1/8"	G2"	180	226	146	22	66
	80	98	52	G1/4"	G2"	195	241	146	22	66
	100	121	63	G1/4"	G2"	213	259	146	22	66

## EMCP Series Plastic Actuator Angle Valve



EMCP	--	10	-	40	--	A	--	S1
		Port Size		Actuator Size		Type		Material
		10: 3/8"		40: 40mm		A: Single Acting Normal Close		S1 : SS316
		15: 1/2"		50: 50mm		B: Single Acting Normal Open		S2 : SS304
		20: 3/4"		63: 63mm		C: Double Acting		
		25: 1"		80: 80mm				
		35: 1-1/4"		100: 100mm				
		40: 1-1/2"						
		50: 2"						

EMCP Stainless Steel Series Angle Valve

### How to Order?

Order Example:  
EMCP Plastic series, 3/8" port Size, Actuator size:40mm, Single Acting Normal Close, SS304 Valve Body, Model: EMCP10-40AS2  
Note: Here we update model No. as the S1=SS316, S2=SS304

## EMCP Series Plastic Actuator Angle Valve

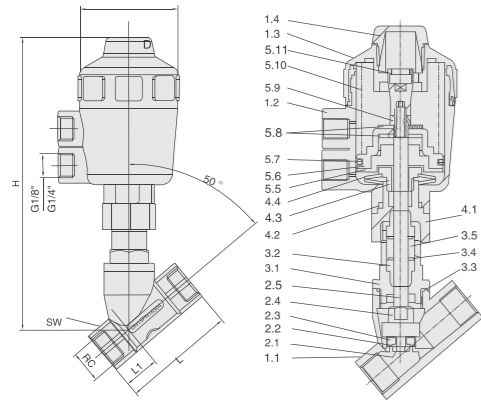

### Main dimensions

DN	RC	L	L1	SW	H	D	T
10	3/8"	55	17	120	120	54	40
15	1/2"	70	21	26.5	135	63	50
20	3/4"	76	23	32	145	63	50
25	1"	90	25	40	155	63	50
32	1-1/4"	116	32	50	200	81	63
40	1-1/2"	116	32	55.5	230	96	80
50	2"	138	40	68.5	250	96	80

#### List of parts

1.1 Body	3.1 Screw connector	5.5 Piston
1.2 Cylinder	3.2 V sealing	5.6 Flange
1.3 Cylinder head	3.3 Seal ring	5.7 Seal ring
1.4 Ornament cover	3.4 Gasket	5.8 Gasket
2.1 Bolt	3.5 Spring	5.9 Hexagon nut
2.2 Orifice plate seal	4.1 Connecting nut	5.10 Spring
2.3 Seal disc	4.2 Seal ring	5.11 Position indicator
2.4 Disc	4.3 Lock nut	
2.5 Stem	4.4 Leaf spring	

### Specifications

Model	EMCP10-50A/B/C
Port size	DN10—DN50
Thread	G3/8"—G2"
Body material	SS316/SS304
Actuator material	Engineering plastic
Applicable medium	water, neutral gas or liquid, ethanol, organic solvent, steam, alkaliescent and weak acid solution
Temperature of medium( )	PTFE : -10~+180FPM : -10~+1 00
Viscosity(mm <sup>2</sup> /s)	Max.600mm <sup>2</sup> /s

Model	EMCP10-50A/B/C
Installation	Any position
Controlling medium	Air, neutral gas
Controlling Pressure(Bar)	3~8
Working pressure(Bar)	0~16
Seat seal	PTFE/FPM
Stem Seal	PTFE/FPM
Piston Seal	FPM/NBR

## BS Series 2.5"~6" Big Size Solenoid Valve

### BS Series Solenoid Valve

BS80E2F



### How to Order?

BS	--	65	--	E1	--	F
BS Series big size solenoid valve		Port size 65: 65mm 80: 80mm 100: 100mm 125: 125mm 150: 150mm		Voltage E1: AC110V E2: AC220V E7: AC24V E11: AC240V		Flange connection

### Order Example:

BS series, 2 position, 2 port, 80mm flange connection, AC 220V, Model : BS80E2F  
BS series, 2 position, 2 port, 125mm flange connection, AC 110V, Model : BS125E1F

### Specifications

Model	BS65E2F	BS90E2F	BS100E2F	BS125E2F	BS150E2F
Working Pressure	0.3~8Bar				
Medium	Water, Hot water, Air, Gas, light oil<20cst				
Medium Temperature	75				
Voltage	AC : 110V 220V AC24V AC240 50/60HZ				
Insulation Class	B				
Voltage Tolerance	-10%~+10%				
Power	DN65~100 15W, DN125~150 30W				
Response Time	3~5sec				
Mounting Type	Clean medium, follow the arrow direction, upright, put a plastic cup on the coil when using in humidity environment for longer life.				
Body Material	Casting Steel				
Flange size	4 holex 17.5x145L	4 holex 17.5x160L	4 holex 17.5x180L	4 holex 17.5x210L	4 holex 22x240L

## BSS Series 2.5"~6" Steam Solenoid Valve

### BSS Series Solenoid Valve

BSSE2-80F



### How to Order?

BSS	--	65	--	E2	--	F
BSS Series big size steam solenoid valve		Port size 65: 65mm 80: 80mm 100: 100mm 150: 150mm		Voltage E2: AC220V E3: AC380V E4: DC24V E6: DC36V E8: DC110V		Flange connection

### Order Example:

BSS series, 2 position, 2 port, 80mm flange connection, AC 220V, Model : BSS80E2F  
BSS series, 2 position, 2 port, 150mm flange connection, DC 24V, Model : BSS150E4F

### Specifications

Model	BSS65E2F	BSS80E2F	BSS100E2F	BSS150E2F
Working Pressure	0.5~16Bar			
Medium	Steam, Water, Hot water, Air, Gas, light oil<20cst			
Medium Temperature	180			
Voltage	AC: 380V 220V 36V/50HZ DC: 24V 110V			
Insulation Class	B			
Voltage Tolerance	-10%~+10%			
Power	50W			
Response Time	Open 3s Close 5s			
Mounting Type	Clean medium, follow the arrow direction, upright, put a plastic cup on the coil when using in humidity environment for longer life.			
Body Material	Casting Steel			
Flange size	4 holex 17.5x145L	4 holex 17.5x160L	4 holex 17.5x180L	4 holex 22x240L

## HS/HSS Series 2.5"~12" Solenoid Valve

### How to Order?

#### Order Example:

HS series, 2 position, 2 port, 80mm flange connection, casting steel body, AC 220V, Model : HS80E2F

HSS series, 2 position, 2 port, 150mm flange connection, SS304 body, DC24V, Model : HS150E4FS2

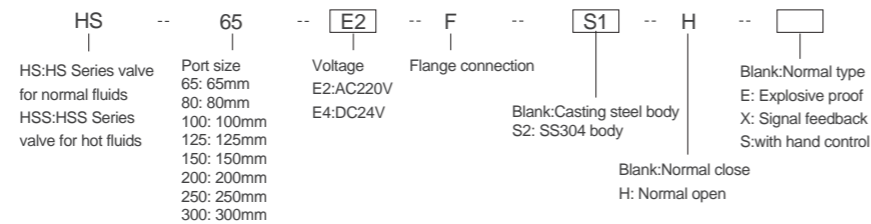

### HS/HSS Series Solenoid Valve

- HSE2-80F
- HSSE2-80F



### Specifications

Model	HS65E2F HSS65E2F	HS80E2F HSS80E2F	HS100E2F HSS100E2F	HS125E2F HSS125E2F	HS150E2F HSS150E2F	HS200E2F HSS200E2F	HS250E2F HSS250E2F	HS300E2F HSS300E2F
Working Pressure	1~16Bar							
Medium	HS: water, air, gas, light oil <20cst, HSS: hot water, steam, hot oil, hot air <20cst							
Medium Temperature	HS 75 , HSS 220							
Ambient Temperature	-20 ~60							
Voltage	AC: 220V 50/60HZ, DC: 24V							
Insulation Class	Class B							
Voltage Tolerance	-10%~+10%							
Power	AC: 20W DC:30W				AC: 35W DC:50W			
Response Time	DN65~DN200:2S, DN250~DN300:3S							
Mounting Type	Keep coil upright, mounting according to actual space							
Body Material	HS:Casting Steel HSS: SS304							
Flange size	4 hole x 18x145L	4 hole x 18x160L	4 hole x 18x180L	4 hole x 18x210L	4 hole x 22x240L	4 hole x 22x295L	4 hole x 26x355L	4 hole x 26x410L

## EMC Series 2/2 Direct Acting Solenoid Valve(Normal Close)

### How to Order?

#### Order Example:

EMC 2/2 Direct Acting series, 1/8" port size, Orifice:1mm, Valve Body:20\*25mm, Voltage:AC220V, Model:EMC22001-06AE2

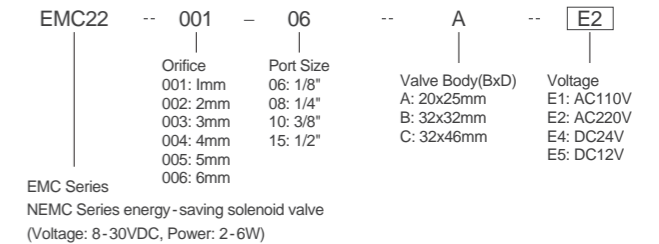

### EMC Series Solenoid Valve

- EMC22001-06AE2
- EMC22003-06BE2
- EMC22006-15E2

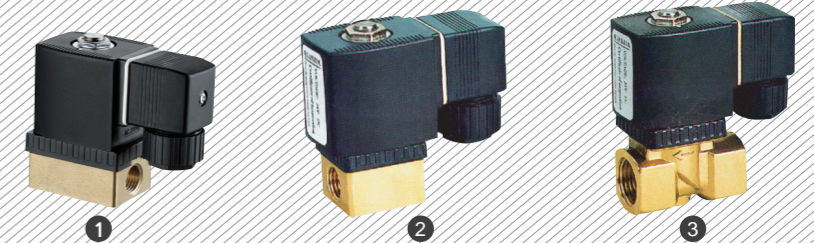

### Specifications

Model	Orifice (mm)	Port Size	Working Pressure(bar)	KV(m <sup>3</sup> /h)	Ambient Temperature( )	Medium Temperature( )
EMC22001-06AE2	1	1/8	0~8	0.02	-10~+50	-10~+80
EMC22002-06AE2	2	1/8	0~6	0.08		
EMC22001-06BE2	1	1/8	0~4	0.02		
EMC22002-06BE2	2	1/8	0~25	0.08		
EMC22003-06BE2	3	1/8	0~10	0.16		
EMC22003-08CE2	3	1/4	0~10	0.16		
EMC22004-08CE2	4	1/4	0~6	0.25		
EMC22005-08CE2	5	1/4	0~3	0.32		
EMC22006E2-08/10/15	6	1/4-1/2	0~2	0.54		
NEMC22001-06AE4						
NEMC22002-06AE4						
NEMC22003-06AE4						
NEMC22004-08AE4						
NEMC22005-08AE4						
NEMC22006E4-08/10/15						



## EMC Series 3/2 Direct Acting Solenoid Valve(Normal Close)

### How to Order?

#### Order Example:

EMC 3/2 Smart direct acting series, 1/8" port size, Orifice:1.5mm, Valve Body:32 x 32mm, Voltage : AC220V, Model : EMC23001-06BE2

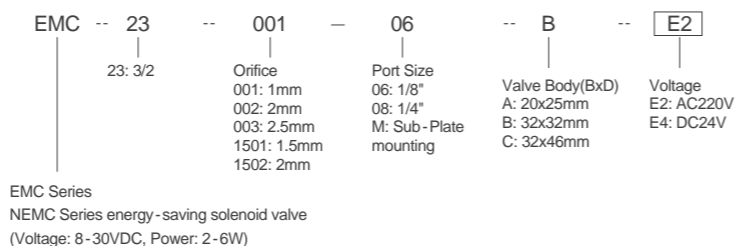

### EMC Series Solenoid Valve

1. EMC23001-06BE2
2. EMC23001-08CE2
3. EMC23002-08CE2

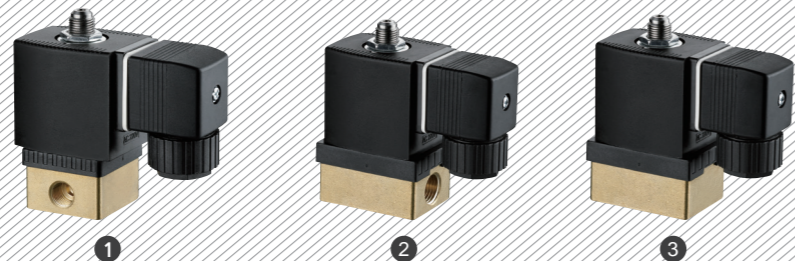

### Specifications

Model	Orifice (mm)	Port Size	Working Pressure(bar)	KV(m³/h)	Ambient Temperature( )	Medium Temperature( )
EMC23001-06BE2	NEMC23001-06BE4	1.5	1/8	0~16	0.02	-10~+80
EMC23002-06BE2	NEMC23002-06BE4	2	1/8	0~10	0.08	
EMC23003-06BE2	NEMC23003-06BE4	2.5	1/8	0~6	0.16	
EMC23001-08CE2	NEMC23001-08BE4	1.5	1/4	0~16	0.02	
EMC23002-08CE2	NEMC23002-08BE4	2	1/4	0~10	0.08	
EMC23003-08CE2	NEMC23003-08BE4	2.5	1/4	0~6	0.16	
EMC231501-MBE2	NEMC231501-MBE4	1.5	Panel mounting	0~16	0.02	
EMC231502-MBE2	NEMC231502-MBE4	2	Panel mounting	0~10	0.08	

## EMC Series 2/2 Pilot-Diaphragm Solenoid Valve(Normal Close, Normal Open)

### How to Order?

#### Order Example:

EMC 2/2 Pilot-Diaphragm series, 1/4" port size, normal close, Voltage:AC220V, Model:EMC008BE2

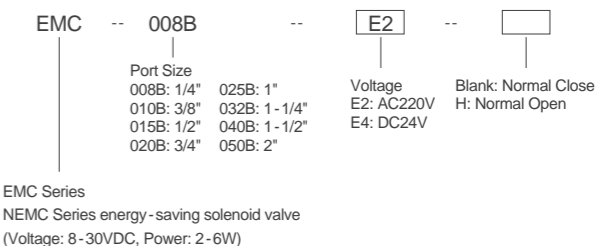

### EMC Series Solenoid Valve

1. EMC008BE2
2. EMC040BE2

Popular Europe type,  
available with both N.C and N.O, 1/4"~2"



### Specifications

Model	Orifice (mm)	Port Size	Working Pressure(bar)	KV(m³/h)	Ambient Temperature( )	Medium Temperature( )
EMC008BE2	NEMC008BE4	10	1/4"	0.3~10	1.4	-5~+80
EMC010BE2	NEMC010BE4	10	3/8"	0.3~10	1.4	
EMC015BE2	NEMC015BE4	10	1/2"	0.3~10	1.4	
EMC015-14BE2/EMC015-14BE2H	NEMC015-14BE4/NEMC015-14BE4H	14	1/2"	0.3~10	2.52	
EMC020BE2/EMC020BE2H	NEMC020BE4/NEMC020BE4H	14	3/4"	0.3~10	2.52	
EMC020-20BE2/EMC020-20BE2H	NEMC020-20BE4/NEMC020-20BE4H	20	3/4"	0.3~10	5	
EMC025BE2/EMC025BE2H	NEMC025BE4/NEMC025BE4H	20	1"	0.3~10	5	
EMC032BE2/EMC032BE2H	NEMC032BE4/NEMC032BE4H	40	1-1/4"	0.7~16	18	
EMC040BE2/EMC040BE2H	NEMC040BE4/NEMC040BE4H	40	1-1/2"	0.7~16	18	
EMC050BE2/EMC050BE2H	NEMC050BE4/NEMC050BE4H	50	2"	0.7~16	28	

\* In Order to Make the Valve Open and Close Completely, there should be at least 0.7 Bar Pressure difference

## EMC Series 2/2 Direct Acting Diaphragm Solenoid Valve(Normal Close)

### How to Order?

#### Order Example:

EMC Series 2/2 Direct Acting Diaphragm Solenoid Valve, 1/4" port size, Normal Close, Voltage : AC220V, Model : EMC008E2

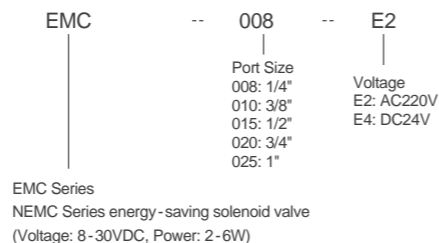

EMC Series Solenoid Valve

EMC008



### Specifications

Model	Orifice (mm)	Port Size	Working Pressure(bar)	KV(m <sup>3</sup> /h)	Ambient Temperature( )	Medium Temperature( )
EMC008E4 NEMC008E4	10	1/4"	0~10	1.4	-5~+80	-10~+80
EMC010E4 NEMC010E4	10	3/8"	0~10	1.4		
EMC015E4 NEMC015E4	10	1/2"	0~10	1.4		
EMC015-14E4 NEMC015-14E4	14	1/2"	0~10	2.52		
EMC020E4 NEMC020E4	14	3/4"	0~10	2.52		
EMC020-20E4 NEMC020-20E4	20	3/4"	0~10	5.0		
EMC025E4 NEMC025E4	20	1"	0~10	5.0		

## EMCS Series 2/2 Pilot-Diaphragm Solenoid Valve(Normal Close, Normal Open)

### How to Order?

#### Order Example:

EMCS Series 2/2 Pilot-Diaphragm Solenoid Valve, 1/4" port size, normal close, Voltage: AC220V, Model: EMCS008BE2

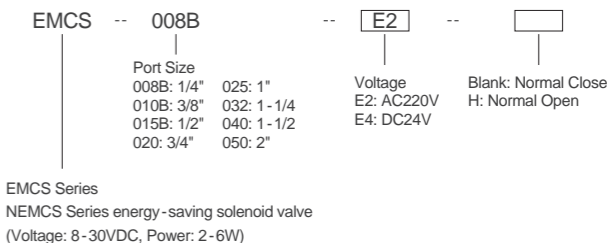

EMCS Series Solenoid Valve

1. EMCS015BE2  
2. EMCS032BE2



### Specifications

Model	Orifice (mm)	Port Size	Working Pressure(bar)	KV(m <sup>3</sup> /h)	Ambient Temperature( )	Medium Temperature( )
EMCS008BE2 NEMCS008BE4	10	1/4"	0.3~10	1.4	-10~+50	-10~+80
EMCS010BE2 NEMCS010BE4H	10	3/8"	0.3~10	1.4		
EMCS015BE2 NEMCS015BE4	10	1/2"	0.3~10	1.5		
EMCS015-14BE2 NEMCS015-14BE4	14	1/2"	0.3~10	5		
EMCS020BE2 NEMCS020BE4	14	3/4"	0.3~10	5		
EMCS025E2 NEMCS025BE4	22	1"	0~10	6.4		
EMCS032BE2/EMCS032BE2H NEMCS032BE4/ NEMCS032BE4H	40	1-1/4"	0.5~16	18		
EMCS040BE2/EMCS040BE2H NEMCS040BE4/ NEMCS040BE4H	40	1-1/2"	0.5~16	18		
EMCS050BE2/EMCS050BE2H NEMCS050BE4/ NEMCS050BE4H	50	2"	0.5~16	24		

## EGV Series 2/2 Gas Solenoid Valve (Normal Close)

### How to Order?

#### Order Example:

EGV Series, 2 position, 2 port, AC110V, 1/8" port size, orifice 3mm, Normal Close, NBR Seal, Model : EGV06E1-3L

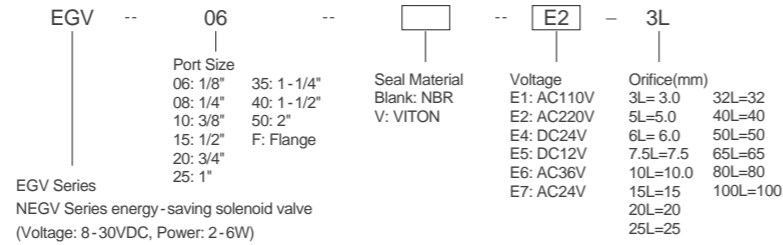

### EGV Series Solenoid Valve

1. EGV08E2-3L
2. EGV08E2-5L
3. EGV10E2-15L

Gas control,  
1/8"~4"



### Specifications

Model	EGV 06-3L	EGV 08-3L	EGV 06-5L	EGV 08-5L	EGV 10-5L	EGV 15-5L	EGV 10-6L	EGV 15-6L	EGV 10-7.5L	EGV 15-7.5L	EGV 10-10L	EGV 15-10L	EGV 15	EGV 20	EGV 25	EGV 35	EGV 40	EGV 50	EGV 40F	EGV 50F	EGV 65F	EGV 80F	EGV 100F			
Orifice	3		5			6		7.5		10		15		20		25		32		40		50		100F		
Port Size	1/8"	1/4"	1/8"	1/4"	3/8"	1/2"	3/8"	1/2"	3/8"	1/2"	3/8"	1/2"	1/2"	3/4"	1"	1-1/4"	1-1/2"	2"	4-	175	4-	175	4-	175	4-	175
CV Value	0.3		0.6			0.7		1.0		1.7		4.6		7.6		12		20		28		46		160		
Max. Working Pressure(Bar)	3		5			2.5		0.5		0.3		2.5						1.0						0.6		
Working Medium	Gas, Air, Neutral Liquid																									
Seal Material	NBR VITON																									
Medium Temperature( )	-5 ~60																									
Voltage	AC:220V 110V 36V 24V DC:24V 12V																									
Power	15W												30W						50W							

## EDG Series 2/2 Gas Solenoid Valve (Normal Close)

### How to Order?

#### Order Example:

EDG Series, 1/4" port size, 2 position, 2 port, NBR seal, AC110V, orifice 6mm, Normal Close, Model : EDG08E1-6L

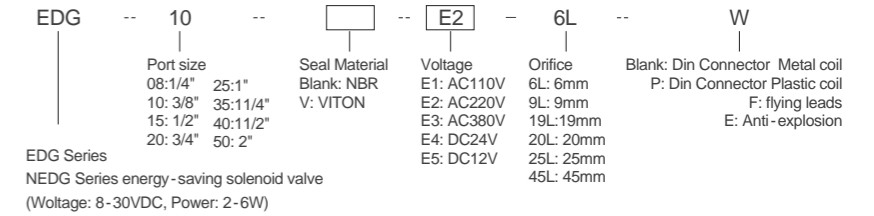

EDG Series  
NEDG Series energy-saving solenoid valve  
(Voltage: 8-30VDC, Power: 2-6W)

### EDG Series Solenoid Valve

1. EDG25E2-25L
2. EDG08E2-6L

Aluminium body,  
especially for gas,  
1/4"~2"

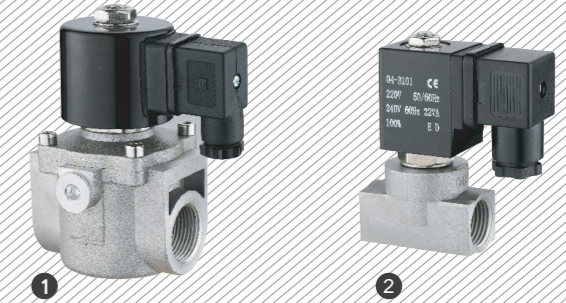

### Specifications

Port Size	Orifice (mm)	CV Value	Pressure Difference (Bar)		Max. Temperature ( )	EDG			NEDG		Module	Main dimension	
			Min. Pressure	Max. Working Pressure		AC VA	DC W	DC W					
1/4"	6	0.8	0	2	NBR:65 VITON:100	22	13	2.6	2.6	2.6	EDG-08E2-6L	NEDG-08E2-6L	51x35x91
1/4"	9	1.2	0	0.6		22	13	2.6	2.6	2.6	EDG-08E2-9L	NEDG-08E2-9L	51x35x91
3/8"	6	0.8	0	2		22	13	2.6	2.6	2.6	EDG-10E2-6L	NEDG-10E2-6L	51x35x91
3/8"	9	1.4	0	0.6		22	13	2.6	2.6	2.6	EDG-10E2-9L	NEDG-10E2-9L	51x35x91
1/2"	9	1.4	0	0.6		22	13	2.6	2.6	2.6	EDG-15E2-9L	NEDG-15E2-9L	51x35x91
1/2"	19	7.5	0	0.36		33	20	4	4	4	EDG-15E2-19L	NEDG-15E2-19L	70x73x122
3/4"	19	7.5	0	0.36		33	20	4	4	4	EDG-20E2-19L	NEDG-20E2-19L	70x73x122
1"	25	13	0	0.36		33	20	4	4	4	EDG-25E2-25L	NEDG-25E2-25L	90x75x127
1-1/4"	45	31	0	0.5		41	34	6	6	6	EDG-35E2-45L	NEDG-35E2-45L	137x122x208
1-1/2"	45	31	0	0.5		41	34	6	6	6	EDG-45E2-45L	NEDG-45E2-45L	137x122x208
2"	45	31	0	0.5		41	34	6	6	6	EDG-50E2-45L	NEDG-50E2-45L	137x122x208

## GUC Series Solenoid Valve

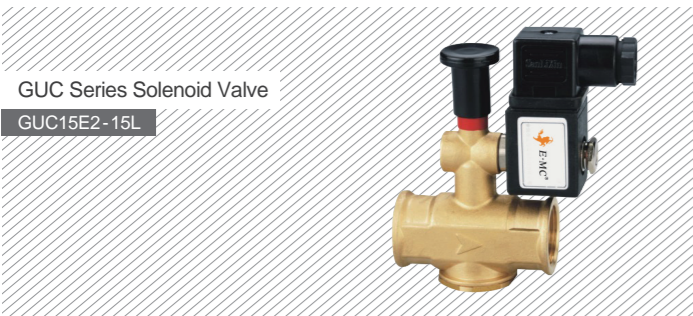

GUC Series Solenoid Valve

GUC15E2-15L

### How to Order?

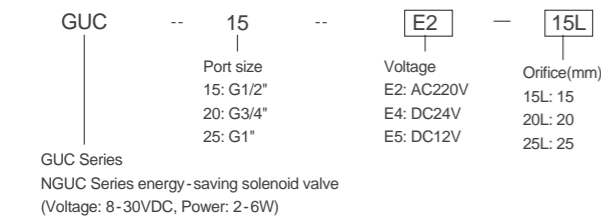

### Order Example:

GUC series, 2 position, 2 port, port size G 1/2", Orifice 15mm, AC 220V, Model : GUC15E2-15L

### Specifications

Model	GUC15E2-15L	GUC20E2-15L	GUC20E2-20L	GUC25E2-25L
Working Pressure	0-500mbar			
Medium	Gas			
Ambient Temperature	-15~60			
Voltage	AC : 220V DC24V Others special made			
Voltage Tolerance	-10%~+10%			
Power	AC: 8VA DC: 7W			
Body Material	Brass			
Seal material	VITON (NBR is optional)			

## SLPL Series Solenoid Valve



SLPL Series Solenoid Valve

SLPL10E4-13L

### How to Order?

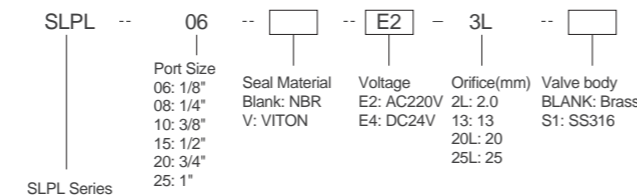

### Order Example:

SLPL series, 2 position, 2 port, AC220V, 1/8" port size, orifice 2mm, Normal Close, NBR Seal, Model : SLPL06E2-2L

### Specifications

Model	SLPL06 E4-2L	SLPL08 E4-2L	SLPL10 E4-13L	SLPL15 E4-13L	SLPL20 E4-20L	SLPL25 E4-25L
Port Size	1/8"	1/4"	3/8"	1/2"	3/4"	1"
Orifice (mm)	2	2	13	13	20	25
CV Value	0.14	0.14	4.5	4.5	7.6	12
Pressure Difference (Bar)	Min. 0		Max. 0.5			
Max temperature	NBR:65, VITON:100					
Power	1.4w					
Main dimensions	40*29*83	40*29*83	68*48*108	68*48*108	75*58*112	96*70*125

## BM Series Bistable Solenoid Valve (Normal Close)

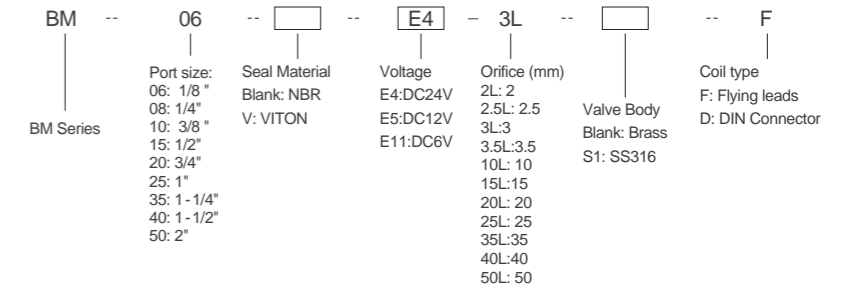

### Order Example:

BM series, 2 position, 2 port, NBR seal, DC 24V, 1/2" port size, Orifice 15 mm Brass Valve body, Model: BM15E4-15L

### BM Series Solenoid Valve

BM-15E4  
BM-20E4D



### Specifications

Port Size	Orifice (mm)	CV Value	Min. Pressure	Pressure Difference (Bar)		Max. Temperature ( )	Resistance	Mode 220VAC 50/60HZ	
				Air / Gas	Water / Hot Water / Liquid			Brass	Stainless Steel
1/8"	2	0.14	0	10	10	80	12.5	BM06E2-2LD	BM06E2-2LS2D
	2.5	0.23	0	9	9	80	12.5	BM06E2-2.5LD	BM06E2-2.5LS2D
	3	0.3	0	8	8	80	12.5	BM06E2-3LD	BM06E2-3LS2D
	3.5	0.4	0	6	6	80	12.5	BM06E2-3.5LD	BM06E2-3.5LS2D
1/4"	2	0.14	0	5	5	80	12	BM08E2-2LF	-
	2	0.14	0	10	10	80	12.5	BM08E2-2LD	BM08E2-2LS2D
	2.5	0.23	0	9	9	80	12.5	BM08E2-2.5LD	BM08E2-2.5LS2D
	3	0.3	0	8	8	80	12.5	BM08E2-3LD	BM08E2-3LS2D
3/8"	3.5	0.4	0	6	6	80	12.5	BM08E2-3.5LD	BM08E2-3.5LS2D
	3	0.3	0	8	8	80	12.5	BM10E2-3LD	BM10E2-3LS2D
	3.5	0.4	0	6	6	80	12.5	BM10E2-3.5LD	BM10E2-3.5LS2D
	10	4.5	0.5	10	10	80	12	-	-
1/2"	10	4.5	0.5	16	16	80	12.5	BM10E2-10LD	BM10E2-10LS2D
	15	4.5	0.5	10	10	80	12	BM15E2-15LF	-
3/4"	15	4.5	0.5	16	16	80	12.5	BM15E2-15LD	BM15E2-15LS2D
	20	7.6	0.5	10	10	80	12	BM20E2-20LF	-
1"	20	7.6	0.5	16	16	80	12.5	BM20E2-20LD	BM20E2-20LS2D
	25	12	0.5	10	10	80	12	BM25E2-25LF	-
1-1/4"	25	12	0.5	16	16	80	12.5	BM25E2-25LD	BM25E2-25LS2D
	35	22	0.5	10	10	80	12	BM35E2-35LF	-
1-1/2"	35	22	0.5	16	16	80	12.5	BM35E2-35LD	BM35E2-35LS2D
	40	30	0.5	10	10	80	12	BM40E2-40LF	-
2"	40	30	0.5	16	16	80	12.5	BM40E2-40LD	BM40E2-40LS2D
	50	48	0.5	10	10	80	12	BM50E2-50LF	-
	50	48	0.5	16	16	80	12.5	BM50E2-50LD	BM50E2-50LS2D

## EDT Series 2/2 Solenoid Valve (Normal Close)

### How to Order?

#### Order Example:

EDTseries, 1/8" Port Size ,AC110V, orifice 1.5mm, DIN connector, Model : EDT06E1 -3L

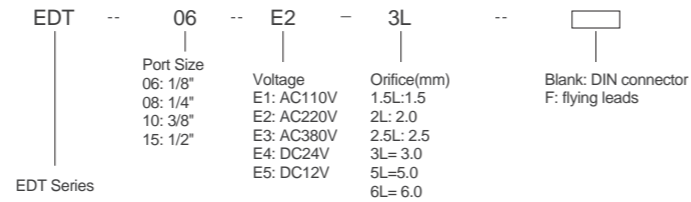

### EDT Series Solenoid Valve

EDT08E2-2LF

-100~200



### Specifications

Port Size	Orifice (mm)	CV Value	Pressure Difference (Bar)			Max. Temperature ( )		Power	Model	Main dimension
			Min. Pressure	Max. Working Pressure		Low Temperature	Steam			
				Low Temperature	Steam					
1/8"	1.5	0.08	0	50	30	-100~-10	99~200	AC27V(16W), DC24V	EDT-06E2-1.5L	72x50x104
1/8"	2	0.14	0	30	20	-100~-10	99~200	AC27V(16W), DC24V	EDT-06E2-2L	72x50x104
1/8"	2.5	0.23	0	17	17	-100~-10	99~200	AC27V(16W), DC24V	EDT-06E2-2.5L	72x50x104
1/8"	3	0.3	0	13	13	-100~-10	99~200	AC27V(16W), DC24V	EDT-06E2-3L	72x50x104
1/4"	4	0.6	0	7	7	-100~-10	99~200	AC27V(16W), DC24V	EDT-06E2-4L	72x50x104
1/4"	1.5	0.08	0	50	30	-100~-10	99~200	AC27V(16W), DC24V	EDT-08E2-1.5L	72x50x104
1/4"	2	0.14	0	30	20	-100~-10	99~200	AC27V(16W), DC24V	EDT-08E2-2L	72x50x104
1/4"	2.5	0.23	0	17	17	-100~-10	99~200	AC27V(16W), DC24V	EDT-08E2-2.5L	72x50x104
1/4"	3	0.3	0	13	13	-100~-10	99~200	AC27V(16W), DC24V	EDT-08E2-3L	72x50x104
1/4"	4	0.6	0	7	7	-100~-10	99~200	AC27V(16W), DC24V	EDT-08E2-4L	72x50x104
3/8"	5	0.65	0	5	5	-100~-10	99~200	AC27V(16W), DC24V	EDT-10E2-5L	72x50x104
3/8"	6	0.8	0	4	4	-100~-10	99~200	AC27V(16W), DC24V	EDT-10E2-6L	72x50x104
1/2"	5	0.65	0	5	5	-100~-10	99~200	AC27V(16W), DC24V	EDT-15E2-5L	72x50x104
1/2"	6	0.8	0	4	4	-100~-10	99~200	AC27V(16W), DC24V	EDT-15E2-6L	72x50x104

## EPT Series 2/2 Solenoid Valve (Normal Close)

### How to Order?

#### Order Example:

EPTseries, 2 position, 2 port ,3/8" port size, AC110V, orifice 13mm, Normal Close, NBR Seal, Model : EPT10E1 -13L

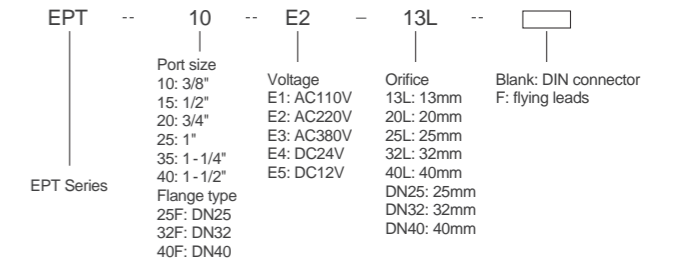

### EPT Series Solenoid Valve

EPT15E2-13L

-80~185

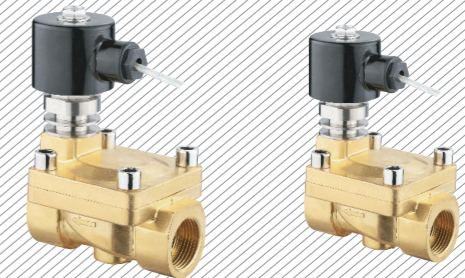

### Specifications

Port Size	Orifice (mm)	CV Value	Pressure Difference (Bar)			Max. Temperature ( )		Power	Model	Main dimension
			Min. Pressure	Max. Working Pressure		Low Temperature	Steam			
				Low Temperature	Steam					
3/8"	13	4.2	1	15	10	-80~-10	99~185	AC: 27VA (16W) DC: 24W	EPT10E2-13L	66x48x157
1/2"	13	4.2	1	15	10	-80~-10	99~185		EPT15E2-13L	66x48x157
3/4"	20	7.3	1	15	10	-80~-10	99~185		EPT20E2-20L	75x58x165
1"	25	11.5	1	15	10	-80~-10	99~185		EPT25E2-25L	96x70x176
1-1/4"	32	22	1	15	10	-80~-10	99~185		EPT35E2-32L	131x96x196
1-1/2"	40	29	1	15	10	-80~-10	99~185		EPT40E2-40L	131x96x196
Flange connection	25	11.5	1	15	10	-80~-10	99~185		EPT25FE2	148x100x202
	32	22	1	15	10	-80~-10	99~185		EPT35FE2	161x135x230
	40	29	1	15	10	-80~-10	99~185		EPT40FE2	161x145x325

# EV Series 3/2 Direct Acting Solenoid Valve(Normal Close)

## How to Order?

### Order Example:

EV series,2 position,3 port,directional type,AC110V,1/8" port size,orifice:3mm, brass valve body,NBR Seal, Model:EV3-06E1-3LD  
 EV series,2 position,3 port,normal open,AC220V,1/4" port size,orifice:1.5mm, stainless steel valve body,VITON Seal, Model:EV2-08VE2-1.5LS2F

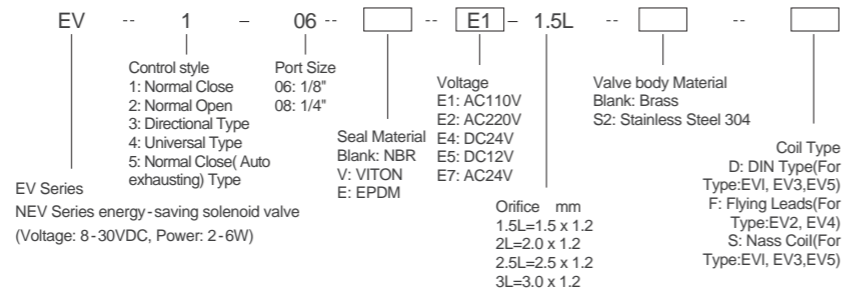

## EV Series Solenoid Valve

- 1.EV1/EV3/EV5 Series
- 2.EV2/EV4 Series



## Specifications

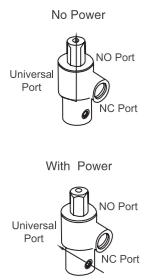

Port Size	Orifice (mm)		CV Value		Pressure Difference (Bar)						EV			NEV			Mode 220VAC 50/60HZ	
	Body	Top	Body	Top	Min.Pressure	Max. Working Pressure				20CSTT	VA	W	W	Valve body material				
						Air / Gas	Water /Liquid	Light Oil	DC					AC	DC	AC	DC	Brass
1/8"	1.5	1.2	0.07	0.05	0	8	5	8	5	8	5	22	13	2.6	EV1-06E2-1.5LD	EV1-06E2-1.5LS2D		
	2.0	1.2	0.14	0.05	0	6	5	6	5	6	5	22	13	2.6	EV1-06E2-2.0LD	EV1-06E2-2.0LS2D		
	2.5	1.2	0.21	0.05	0	5	4	5	4	5	4	22	13	2.6	EV1-06E2-2.5LD	EV1-06E2-2.5LS2D		
	3.0	1.2	0.23	0.05	0	4	3	4	3	4	3	22	13	2.6	EV1-06E2-3.0LD	EV1-06E2-3.0LS2D		
1/4"	1.5	1.2	0.07	0.05	0	8	5	8	5	8	5	22	13	2.6	EV1-08E2-1.5LD	EV1-08E2-1.5LS2D		
	2.0	1.2	0.14	0.05	0	6	5	6	5	6	5	22	13	2.6	EV1-08E2-2.0LD	EV1-08E2-2.0LS2D		
	2.5	1.2	0.21	0.05	0	5	4	5	4	5	4	22	13	2.6	EV1-08E2-2.5LD	EV1-08E2-2.5LS2D		
	3.0	1.2	0.23	0.05	0	4	3	4	3	4	3	22	13	2.6	EV1-08E2-3.0LD	EV1-08E2-3.0LS2D		

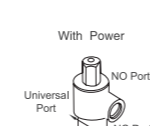
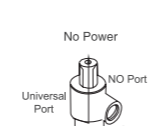
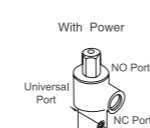
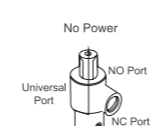
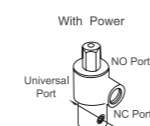
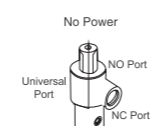
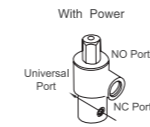
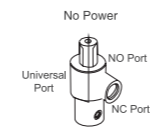

Port Size	Orifice (mm)		CV Value		Pressure Difference (Bar)						EV			NEV			Mode 220VAC 50/60HZ	
	Body	Top	Body	Top	Min.Pressure	Max. Working Pressure				20CSTT	VA	W	W	Valve body material				
						Air / Gas	Water /Liquid	Light Oil	DC					AC	DC	AC	DC	Brass
1/8"	1.5	1.2	0.07	0.05	0	6	3	6	3	6	3	22	13	2.6	EV2-06E2-1.5LF	EV2-06E2-1.5LS2F		
	2.0	1.2	0.14	0.05	0	4	2	4	2	4	2	22	13	2.6	EV2-06E2-2.0LF	EV2-06E2-2.0LS2F		
	2.5	1.2	0.21	0.05	0	4	2	4	2	4	2	22	13	2.6	EV2-06E2-2.5LF	EV2-06E2-2.5LS2F		
	3.0	1.2	0.23	0.05	0	4	2	4	2	4	2	22	13	2.6	EV2-06E2-3.0LF	EV2-06E2-3.0LS2F		
1/4"	1.5	1.2	0.07	0.05	0	6	3	6	3	6	3	22	13	2.6	EV2-08E2-1.5LF	EV2-08E2-1.5LS2F		
	2.0	1.2	0.14	0.05	0	6	3	6	3	6	3	22	13	2.6	EV2-08E2-2.0LF	EV2-08E2-2.0LS2F		
	2.5	1.2	0.21	0.05	0	4	2	4	2	4	2	22	13	2.6	EV2-08E2-2.5LF	EV2-08E2-2.5LS2F		
	3.0	1.2	0.23	0.05	0	4	2	4	2	4	2	22	13	2.6	EV2-08E2-3.0LF	EV2-08E2-3.0LS2F		

Port Size	Orifice (mm)		CV Value		Pressure Difference (Bar)						EV			NEV			Mode 220VAC 50/60HZ	
	Body	Top	Body	Top	Min.Pressure	Max. Working Pressure				20CSTT	VA	W	W	Valve body material				
						Air / Gas	Water /Liquid	Light Oil	DC					AC	DC	AC	DC	Brass
1/8"	1.5	1.2	0.07	0.05	0	12	8	12	8	12	8	22	13	2.6	EV3-06E2-1.5LD	EV3-06E2-1.5LS2D		
	2.0	1.2	0.14	0.05	0	10	7	10	7	10	7	22	13	2.6	EV3-06E2-2.0LD	EV3-06E2-2.0LS2D		
	2.5	1.2	0.21	0.05	0	8	6	8	6	8	6	22	13	2.6	EV3-06E2-2.5LD	EV3-06E2-2.5LS2D		
	3.0	1.2	0.23	0.05	0	7	5	7	5	7	5	22	13	2.6	EV3-06E2-3.0LD	EV3-06E2-3.0LS2D		
1/4"	1.5	1.2	0.07	0.05	0	12	8	12	8	12	8	22	13	2.6	EV3-08E2-1.5LD	EV3-08E2-1.5LS2D		
	2.0	1.2	0.14	0.05	0	10	7	10	7	10	7	22	13	2.6	EV3-08E2-2.0LD	EV3-08E2-2.0LS2D		
	2.5	1.2	0.21	0.05	0	8	6	8	6	8	6	22	13	2.6	EV3-08E2-2.5LD	EV3-08E2-2.5LS2D		
	3.0	1.2	0.23	0.05	0	7	5	7	5	7	5	22	13	2.6	EV3-08E2-3.0LD	EV3-08E2-3.0LS2D		

Port Size	Orifice (mm)		CV Value		Pressure Difference (Bar)						EV			NEV			Mode 220VAC 50/60HZ	
	Body	Top	Body	Top	Min.Pressure	Max. Working Pressure				20CSTT	VA	W	W	Valve body material				
						Air / Gas	Water /Liquid	Light Oil	DC					AC	DC	AC	DC	Brass
1/8"	1.5	1.2	0.07	0.05	0	6	4	6	4	6	4	22	13	2.6	EV4-06E2-1.5LF	EV4-06E2-1.5LS2F		
	2.0	1.2	0.14	0.05	0	5	3.5	5	3.5	5	3.5	22	13	2.6	EV4-06E2-2.0LF	EV4-06E2-2.0LS2F		
	2.5	1.2	0.21	0.05	0	4	3	4	3	4	3	22	13	2.6	EV4-06E2-2.5LF	EV4-06E2-2.5LS2F		
	3.0	1.2	0.23	0.05	0	3.5	2.5	3.5	2.5	3.5	2.5	22	13	2.6	EV4-06E2-3.0LF	EV4-06E2-3.0LS2F		
1/4"	1.5	1.2	0.07	0.05	0	6	4	6	4	6	4	22	13	2.6	EV4-08E2-1.5LF	EV4-08E2-1.5LS2F		
	2.0	1.2	0.14	0.05	0	5	3.5	5	3.5	5	3.5	22	13	2.6	EV4-08E2-2.0LF	EV4-08E2-2.0LS2F		
	2.5	1.2	0.21	0.05	0	4	3	4	3	4	3	22	13	2.6	EV4-08E2-2.5LF	EV4-08E2-2.5LS2F		
	3.0	1.2	0.23	0.05	0	3.5	2.5	3.5	2.5	3.5	2.5	22	13	2.6	EV4-08E2-3.0LF	EV4-08E2-3.0LS2F		

Port Size	Orifice (mm)		CV Value		Pressure Difference (Bar)						EV			NEV			Mode 220VAC 50/60HZ	
	Body	Top	Body	Top	Min.Pressure	Max. Working Pressure				20CSTT	VA	W	W	Valve body material				
						Air / Gas	Water /Liquid	Light Oil	DC					AC	DC	AC	DC	Brass
1/8"	1.5	1.2	0.07	0.05	0	8	5	8	5	8	5	22	13	2.6	EV5-06E2-1.5LD	EV5-06E2-1.5LS2D		
	2.0	1.2	0.14	0.05	0	6	5	6	5	6	5	22	13	2.6	EV5-06E2-2.0LD	EV5-06E2-2.0LS2D		
	2.5	1.2	0.21	0.05	0	5	4	5	4	5	4	22	13	2.6	EV5-06E2-2.5LD	EV5-06E2-2.5LS2D		
	3.0	1.2	0.23	0.05	0	4	3	4	3	4	3	22	13	2.6	EV5-06E2-3.0LD	EV5-06E2-3.0LS2D		
1/4"	1.5	1.2	0.07	0.05	0	8	5	8	5	8	5	22	13	2.6	EV5-08E2-1.5LD	EV5-08E2-1.5LS2D		
	2.0	1.2	0.14	0.05	0	6	5	6	5	6	5	22	13	2.6	EV5-08E2-2.0LD	EV5-08E2-2.0LS2D		
	2.5	1.2	0.21	0.05	0	5	4	5	4	5	4	22	13	2.6	EV5-08E2-2.5LD	EV5-08E2-2.5LS2D		
	3.0	1.2	0.23	0.05	0	4	3	4	3	4	3	22	13	2.6	EV5-08E2-3.0LD	EV5-08E2-3.0LS2D		

## ESV Series 3/2 Direct Acting Solenoid Valve(Normal Close)

### How to Order?

#### Order Example:

ESV series, 2 position, 3 port, normal close, AC110V, 1/8" port size, orifice:1.5mm, brass valve body, NBR Seal, Model:ESV1-06E1-1.5L  
 ESV series, 2 position, 3 port, normal open, AC220V, 1/4" port size, orifice:3mm, stainless steel valve body, VITON Seal, Model:ESV2-08VE2-V3LS2

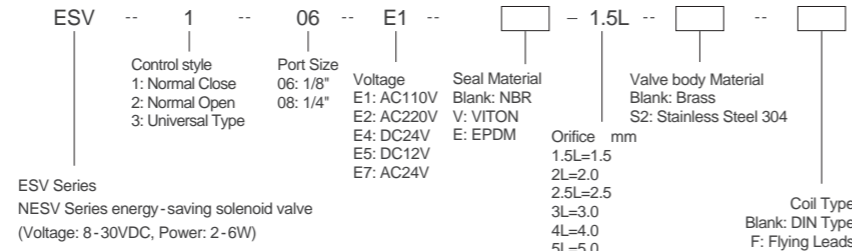

### ESV Series 3/2 Direct Acting Solenoid Valve(Normal Close)

- 1.ESV1-06E2-1.5L
- 2.ESV1-06E2-1.5LS2



### Specifications

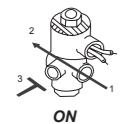
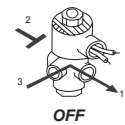

Port Size	Orifice (mm)	CV Value	Pressure Difference (Bar)				EV			NEV		Mode 220VAC 50/60HZ	
			Min.Pressure	Water /Liquid		Light Oil		20CSTT	VA	W	W	Valve body material	
				AC	DC	AC	DC					Brass	Stainless Steel 304
1/8"	1.5	0.07	0	13	11	13	11	80	22	13	2.6	ESV1-06E2-1.5L	ESV1-06E2-1.5LS2
	1.5	0.07	0	13	11	13	11	120	22	13	2.6	ESV1-06VE2-1.5L	ESV1-06VE2-1.5LS2
	2.0	0.14	0	11	9	11	9	80	22	13	2.6	ESV1-06E2-2.0L	ESV1-06E2-2.0LS2
	2.0	0.14	0	11	9	11	9	120	22	13	2.6	ESV1-06VE2-2.0L	ESV1-06VE2-2.0LS2
	2.5	0.21	0	9	7	9	7	80	22	13	2.6	ESV1-06E2-2.5L	ESV1-06E2-2.5LS2
	2.5	0.21	0	9	7	9	7	120	22	13	2.6	ESV1-06VE2-2.5L	ESV1-06VE2-2.5LS2
	3.0	0.25	0	6	4	6	4	80	22	13	2.6	ESV1-06E2-3.0L	ESV1-06E2-3.0LS2
	3.0	0.25	0	6	4	6	4	120	22	13	2.6	ESV1-06VE2-3.0L	ESV1-06VE2-3.0LS2
1/4"	1.5	0.07	0	13	11	13	11	80	22	13	2.6	ESV1-08E2-1.5L	ESV1-08E2-1.5LS2
	1.5	0.07	0	13	11	13	11	120	22	13	2.6	ESV1-08VE2-1.5L	ESV1-08VE2-1.5LS2
	2.0	0.14	0	11	9	11	9	80	22	13	2.6	ESV1-08E2-2.0L	ESV1-08E2-2.0LS2
	2.0	0.14	0	11	9	11	9	120	22	13	2.6	ESV1-08VE2-2.0L	ESV1-08VE2-2.0LS2
	2.5	0.21	0	9	7	9	7	80	22	13	2.6	ESV1-08E2-2.5L	ESV1-08E2-2.5LS2
	2.5	0.21	0	9	7	9	7	120	22	13	2.6	ESV1-08VE2-2.5L	ESV1-08VE2-2.5LS2
	3.0	0.25	0	6	4	6	4	80	22	13	2.6	ESV1-08E2-3.0L	ESV1-08E2-3.0LS2
	3.0	0.25	0	6	4	6	4	120	22	13	2.6	ESV1-08VE2-3.0L	ESV1-08VE2-3.0LS2

## ESV Series 3/2 Direct Acting Solenoid Valve (Normal Close)

### Specifications

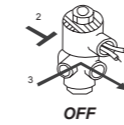

Port Size	Orifice (mm)	CV Value	Pressure Difference (Bar)				EV			NEV		Mode 220VAC 50/60HZ	
			Min.Pressure	Water /Liquid		Light Oil		20CSTT	VA	W	W	Valve body material	
				AC	DC	AC	DC					Brass	Stainless Steel 304
1/8"	1.5	0.07	0	7	5	7	5	80	22	13	2.6	ESV3-06E2-1.5L	ESV3-06E2-1.5LS2
	1.5	0.07	0	7	5	7	5	120	22	13	2.6	ESV3-06VE2-1.5L	ESV3-06VE2-1.5LS2
	2.0	0.14	0	5	4	5	4	80	22	13	2.6	ESV3-06E2-2.0L	ESV3-06E2-2.0LS2
	2.0	0.14	0	5	4	5	4	120	22	13	2.6	ESV3-06VE2-2.0L	ESV3-06VE2-2.0LS2
1/4"	1.5	0.07	0	7	5	7	5	80	22	13	2.6	ESV3-08E2-1.5L	ESV3-08E2-1.5LS2
	1.5	0.07	0	7	5	7	5	120	22	13	2.6	ESV3-08VE2-1.5L	ESV3-08VE2-1.5LS2
	2.0	0.14	0	5	4	5	4	80	22	13	2.6	ESV3-08E2-2.0L	ESV3-08E2-2.0LS2
	2.0	0.14	0	5	4	5	4	120	22	13	2.6	ESV3-08VE2-2.0L	ESV3-08VE2-2.0LS2

Port Size	Orifice (mm)	CV Value	Pressure Difference (Bar)				EV			NEV		Mode 220VAC 50/60HZ	
			Min.Pressure	Water /Liquid		Light Oil		20CSTT	VA	W	W	Valve body material	
				AC	DC	AC	DC					Brass	Stainless Steel 304
1/8"	1.5	0.07	0	13	11	13	11	80	22	13	2.6	ESV2-06E2-1.5L	ESV2-06E2-1.5LS2
	1.5	0.07	0	13	11	13	11	120	22	13	2.6	ESV2-06VE2-1.5L	ESV2-06VE2-1.5LS2
	2.0	0.14	0	11	9	11	9	80	22	13	2.6	ESV2-06E2-2.0L	ESV2-06E2-2.0LS2
	2.0	0.14	0	11	9	11	9	120	22	13	2.6	ESV2-06VE2-2.0L	ESV2-06VE2-2.0LS2
	2.5	0.21	0	9	7	9	7	80	22	13	2.6	ESV2-06E2-2.5L	ESV2-06E2-2.5LS2
	2.5	0.21	0	9	7	9	7	120	22	13	2.6	ESV2-06VE2-2.5L	ESV2-06VE2-2.5LS2
	3.0	0.25	0	6	4	6	4	80	22	13	2.6	ESV2-06E2-3.0L	ESV2-06E2-3.0LS2
	3.0	0.25	0	6	4	6	4	120	22	13	2.6	ESV2-06VE2-3.0L	ESV2-06VE2-3.0LS2
1/4"	1.5	0.07	0	13	11	13	11	80	22	13	2.6	ESV2-08E2-1.5L	ESV2-08E2-1.5LS2
	1.5	0.07	0	13	11	13	11	120	22	13	2.6	ESV2-08VE2-1.5L	ESV2-08VE2-1.5LS2
	2.0	0.14	0	11	9	11	9	80	22	13	2.6	ESV2-08E2-2.0L	ESV2-08E2-2.0LS2
	2.0	0.14	0	11	9	11	9	120	22	13	2.6	ESV2-08VE2-2.0L	ESV2-08VE2-2.0LS2
	2.5	0.21	0	9	7	9	7	80	22	13	2.6	ESV2-08E2-2.5L	ESV2-08E2-2.5LS2
	2.5	0.21	0	9	7	9	7	120	22	13	2.6	ESV2-08VE2-2.5L	ESV2-08VE2-2.5LS2
	3.0	0.25	0	6	4	6	4	80	22	13	2.6	ESV2-08E2-3.0L	ESV2-08E2-3.0LS2
	3.0	0.25	0	6	4	6	4	120	22	13	2.6	ESV2-08VE2-3.0L	ESV2-08VE2-3.0LS2

## 23JVD Series 3/2 Stop Type Solenoid Valve

### 23JVD Series Solenoid Valve

- 1.23JVD-1.6L
- 2.23JVD-1.6
- 3.23JVD-Z16H



### How to Order?

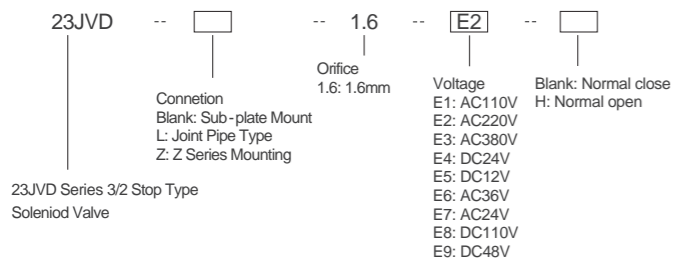

23JVD Series 3/2 Stop Type Solenoid Valve

**Order Example:**  
23JVD Series 3/2 Stop Type Solenoid Valve, Sub-Plate Mounting, orifice: 1.6mm, Normal Close, AC220V, Model: 23JVD1.6E2

### Specifications

Model	23JVD-1.6	
Effective Section Area(mm <sup>2</sup> )	0.5	
Working Pressure(Bar)	0~10	
Ambient temperature( )	-5~40	
Working temperature( )	-5~50	
Directional Duration(S)	0.03	
Directional Fluctuate(%)	-15~+10	
Life cycle	5,000,000	
Voltage(V)	AC	380 220 110 36 24
	DC	110 48 24 12

## K23JD Series 3/2 Solenoid Valve

### K23JD Series Solenoid Valve

K23JD-10



### How to Order?

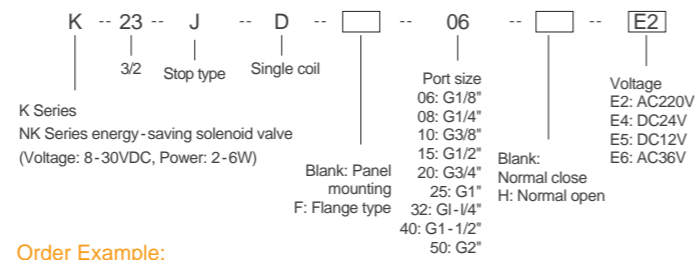

### Order Example:

K series, 3 port, 2 position, Stop type, single coil, panel mounting, port size : G1/8", normal close, AC220V, Model : K23JD-06E2

### Specifications

Model	K23JD-6E2(H)	K23JD-8E2(H)	K23JD-10E2(H)	K23JD-15E2(H)	K23JD-20E2(H)	K23JD-25E2(H)	K23JD-32E2(H)	K23JD-40E2(H)	K23JD-50E2(H)
	NK23JD-6E4(H)	NK23JD-8E4(H)	NK23JD-10E4(H)	NK23JD-15E4(H)	NK23JD-20E4(H)	NK23JD-25E4(H)	NK23JD-32E4(H)	NK23JD-40E4(H)	NK23JD-50E4(H)
Working medium	Clean air								
Acting type	Pilot acting type								
Effective Section Area(mm <sup>2</sup> )	10	20	40	60	110	190	300	400	650
Port size	1/8"	1/4"	3/8"	1/2"	3/4"	1"	1-1/4"	1-1/2"	2"
Working pressure(Bar)	1.5~8								
Guaranteed pressure(Bar)	12								
Voltage range	-15~10%								
Working temperature( )	-5~50								
Life cycle	2,000,000			1,500,000			500,000		
Valve body material	Aluminum								
Seal material	NBR								

## K25JD Series 5/2 Solenoid Valve

### How to Order?

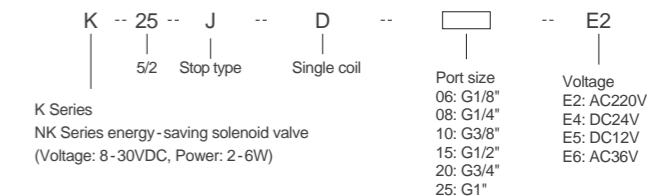

### Order Example:

K series, 5 port, 2 position, Stop type, single coil, port size : G1", AC220V, Model: K25JD-25E2

### K25JD Series Solenoid Valve

K25JD-15E2

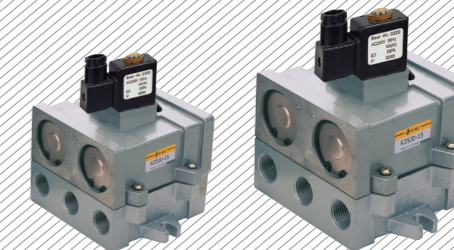

### Specifications

Model	K25JD-6	K25JD-8	K25JD-10	K25JD-15	K25JD-20	K25JD-25
	NK25JD-6E4	NK25JD-8E4	NK25JD-10E4	NK25JD-15E4	NK25JD-20E4	NK25JD-25E4
Working medium	Clean air					
Acting type	Pilot acting type					
Effective Section Area(mm <sup>2</sup> )	10	20	40	60	110	190
Port size	1/8"	1/4"	3/8"	1/2"	3/4"	1"
Working pressure (Bar)	1.5~8					
Guaranteed pressure(Bar)	12					
Voltage range	-15~10%					
Working temperature ( )	-5~50					
Life cycle	5,000,000					
Valve body material	Aluminum					
Seal material	NBR					



## SLG Series 2/2 Solenoid Valve (Normal Close)

SLG Series Solenoid Valve

SLG22-06E2

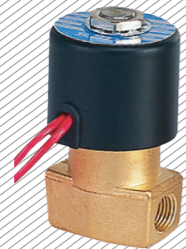

### How to Order?

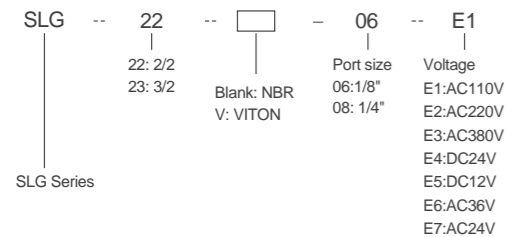

### Order Example:

SLG series, 2 position, 2 port, NBR seal, 1/4" port size, voltage: AC220V, Model : SLG22-08E2

### Specifications

Model	SLG22-06E2	SLG22-08E2	SLG23-06E2	SLG23-08E2
Working medium	Air, water, oil		Air	
Orifice(mm)	1.6			
Cv value	0.1			
Port Size	1/8"	1/4"	1/8"	1/4"
Working pressure (Bar)	0~15		0~9	
Voltage range	± 10%			
Seal material	NBR or VITON			

## EQ Series 2/2 Solenoid Valve (Normal Close)

EQ Series Solenoid Valve

EQ20-25

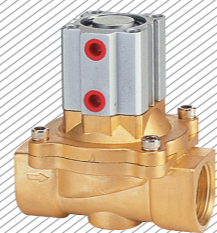

### How to Order?

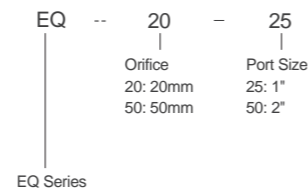

### Order Example:

EQ series, 2 position, 2 port, Orifice: 22mm, 1" port size, Model : EQ20-25

### Specifications

Model	EQ20-25	EQ50-50
Orifice(mm)	20	50
Cv Value	12	48
Port Size	1"	2"
Fluid Viscosity	50 CST Below	
Working Pressure(Bar)	0~7	
Max. Pressure Resistance(Bar)	11	
Control Pressure Range (Bar)	3~6	
Working Temperature( )	-5~100	
Valve Body Material	Brass	
Seal Material	PTFE	
Control Port Size	2-G1/8"	2-G1/4"

## ACV Series Plastic Solenoid Valve

ACV Series Solenoid Valve

1.AC V08E2-6L  
2.AC V15E2-15L



### How to Order?

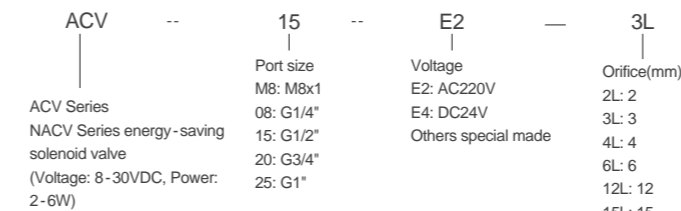

### Order Example:

ACV series, 2 position, 2 port, port size G1/4", Orifice 6 mm, AC 220V, Model : ACV08E2-6L

### Specifications

Model	ACVM8 E2-2L NACVM8 E4-2L	ACVM8 E2-3L NACVM8 E4-3L	ACVM8 E2-4L NACVM8 E4-4L	ACV08 E2-6L NACV08 E4-6L	ACV15 E2-12L NACV15 E4-12L	ACV15 E2-15L NACV15 E4-15L	ACV20 E2-20L NACV20 E4-20L	ACV25 E2-25L NACV25 E4-25L
Working Pressure	0.2MPa			0~0.1MPa		0~0.05MPa		
Medium	Strong acid/Strong base liquid, Ultra-clean medium							
Medium Temperature	0~60			-10~160				
Voltage	AC : 220V DC24V Others special made							
Voltage Tolerance	-10%~+10%							
Power	6.8W		15W			50W		
Body Material	PTFE							
Seal material	PTFE			VITON				

## EMB23-024 Series 3/2 Acting Solenoid Valve (Normal Close)

EMB23 Series Solenoid Valve

EMB23-024E4

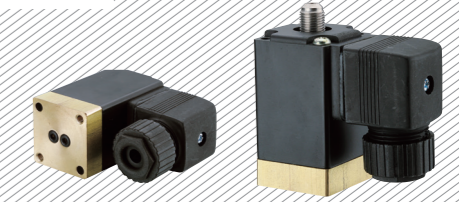

### How to Order?

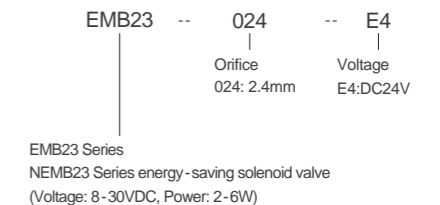

### Order Example:

EMB 3/2 direct acting series, 2.4mm orifice, Voltage D24V, Model : EMB23-024E4

### Specifications

Model	EMB23-024	NEMB23-024
Working Medium	Air	
Acting Type	Direct acting type	
Type	3/2 Normal open type	
Orifice(mm)	2.4	
Working Pressure(Bar)	0~10	
Working Temperature( )	-5~80	
Voltage	DC:24V	
Valve Body Material	Brass	
Seal Material	NBR	

## EMCF Series 2/2 Pulse Valve (Normal Close)

EMCF Series Solenoid Valve

- 1.EMCF -25
- 2.EMCF -50

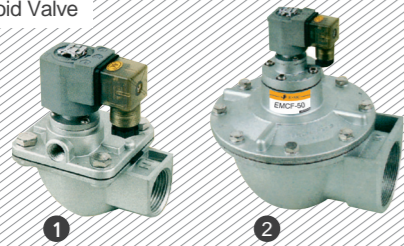

### How to Order?

EMCF	--	25	--	E2
EMCF Series		Orifice		Voltage
NEMCF Series energy-saving solenoid valve		25: 25mm		E2:AC220V
(Voltage: 8-30VDC, Power: 2-6W)		40: 40mm		E4:DC24V
		50: 50mm		
		65: 65mm		
		76: 76mm		

### Order Example:

EMCF series, Orifice:25mm,Voltage:AC220V,Model : EMCF -25E2

### Specifications

Model	EMCF -25E2	EMCF -40E2	EMCF -50E2	EMCF -65E2	EMCF -76E2
	NEMCF -25E4	NEMCF -40E4	NEMCF -50E4	NEMCF -65E4	NEMCF -76E4
Working Pressure(Bar)	4~6				
Working Temperature( )	-10~55				
Relative Humidity	<85%				
Working Medium	Clean air				
Voltage	AC220V/DC24V				
Diaphragm Life	Over one 1,000,000 cycles				
Orifice(mm)	25	40	50	65	76
Port Size	1"	1-1/2"	2"	2-1/2"	3"

## EMCYF Series 2/2 Pulse Valve (Normal Close)

EMCYF Series Solenoid Valve

EMCYF -50E2



### How to Order?

EMCYF	--	50	--	E1
EMCYF Series		Orifice		Voltage
NEMCYF Series energy-saving solenoid valve		50: 50mm		E1:AC110V
(Voltage: 8-30VDC, Power: 2-6W)		65: 65mm		E2:AC220V
		76: 76mm		E4:DC24V

### Order Example:

EMCYF series, Orifice:50mm,Voltage:AC220V,Model : EMCYF -50E2

### Specifications

Model	EMCYF -50E2	EMCYF -62E2	EMCYF -76E2
	NEMCYF -50E4	NEMCYF -62E4	NEMCYF -76E4
Working Pressure(Bar)	2~6		
Working Temperature( )	-10~55		
Relative Humidity	<85%		
Working Medium	Clean air		
Voltage	AV220V/DC24V		
Diaphragm Life	Over one million cycles		
Orifice(mm)	50	62	76
Port Size	65	80	99

## Mini solenoid valve



**Model:** GM22-0.8L  
Type: 2/2 normal close  
Port Size: 1/8"  
Orifice: 0.8mm  
Pressure: 0~8Bar  
Temperature: -5~80  
Material: Brass  
Seal Material: NBR



**Model:** GL23-06-2L  
GL23-06-3L  
Type: 3/2 normal close  
Port Size: 1/8" 1/4"  
Orifice: 2mm 3mm  
Pressure: 0~8Bar  
Temperature: -5~80  
Material: Brass  
Seal Material: NBR



**Model:** EF23-08H  
Type: 3/2 normal close  
Port Size: 1/4"  
Pressure: 0~16 Bar  
Temperature: 0~160  
Material: Brass



**Model:** EMC22-M5  
Type: 2/2 normal close  
Port Size: 5mm  
Orifice: 1 mm  
Pressure: 0~8Bar  
Temperature: -5~85  
Material: PP



**Model:** GM22-1.2L  
Type: 2/2 normal close  
Port Size: M5  
Orifice: 1.2mm  
Pressure: 0~8Bar  
Temperature: -5~80  
Material: Brass  
Seal Material: NBR

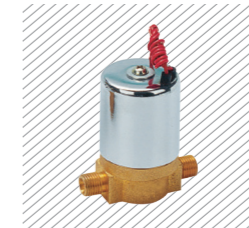

**Model:** G22-06-3L  
Type: 2/2 normal close  
Port Size: 1/8"  
M12x1.25  
Orifice: 3mm  
Pressure: 0~8Bar  
Temperature: -40~150  
Material: Brass  
Seal Material: NBR



**Model:** GCH23-M  
Type: 3/2 normal close  
Orifice: 1.2mm  
Pressure: 0~14Bar  
Temperature: 80~160  
Material: Brass

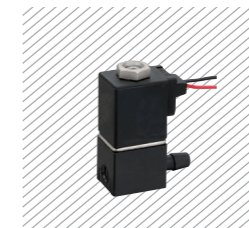

**Model:** ETS23  
Type: 3/2 normal close  
Port Size: In=6mm Pipe  
Out=M6\*1  
Orifice: 1.4mm  
Pressure: 0~2.4Bar  
Material: Reinforced Nylon



**Model:** Q22XD-2L Q22XD-3L Q22XD-4L Q22XD-5L Q23XD-2L Q23XD-3L Q22XD-4L Q23XD-5L  
Type: Normal close, Normal open(Optional)  
Port Size: 1/8" 1/4"  
Orifice: 2mm 3mm 4mm 5mm  
Pressure: 0~8Bar  
Temperature: -5~80  
Material: Brass  
Seal Material: NBR VITON

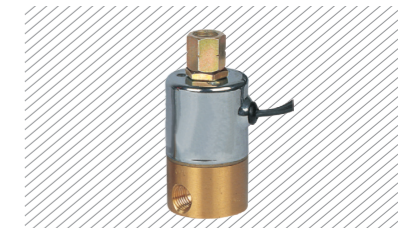

**Model:** GU23-0.6-1.5L GU23-0.6-1.5LH  
Type: 3/2 normal close, normal open(Optional)  
Port Size: 1/4"  
Orifice: 1.5mm 2mm  
Pressure: 0~8Bar  
Temperature: -5~80  
Material: Brass  
Seal Material: NBR

## Technical department report Special valve

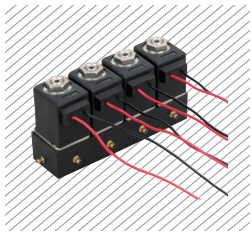

**Model:** PV4-M3  
Type: 3/2 normal close  
Port Size: 1/16"  
Orifice: 1.4mm  
Pressure: 0~2.4Bar  
Material: Reinforced Nylon



**Model:** E6V110-M5-6L  
Type: 3/2 normal close  
Port Size: M5  
Orifice: 1.4mm  
Pressure: 0~8Bar  
Temperature: 0~100  
Material: Aluminium



**Model:** MB22-01  
Type: 2/2 normal close  
Port Size: 1/8" M5  
Orifice: 2.5mm  
Pressure: 0~8Bar  
Temperature: -5~150  
Material: Brass



**Model:** EMC23-12L  
Type: 3/2 normal close  
Port Size: 1/2"  
Orifice: 12mm  
Pressure: 0~10Bar  
Temperature: 0~100  
Material: Aluminium

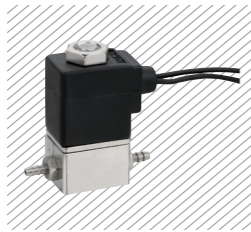

**Model:** V221-M4  
Type: 2/2 normal close  
Port Size: M4  
Orifice: 1mm  
Pressure: 0~10Bar  
Temperature: -5~85  
Material: Brass

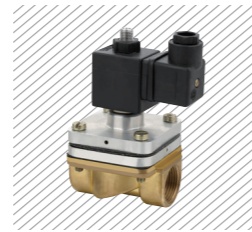

**Model:** MDD23-20  
Type: 3/2  
Port Size: 3/4NPT  
Control pressure: 3.5~10Bar  
Working pressure: 2~4Bar (water)  
Material: Brass  
Seal: VITON



**Model:** C35-06H, C32-06H  
Type: 5/3, 3/2  
Port Size: 1/8"  
Orifice: 2.5mm  
Pressure: 0~10Bar  
Temperature: -5~85  
Material: Aluminium



**Model:** C35-08H  
Type: 5/3  
Port Size: 1/8"  
Pressure: 0~10Bar  
Temperature: 5~85  
Material: Aluminium



**Model:** EQX30323  
Type: 3/2 Quick Exhausting Solenoid Valve  
Port Size: 1/4"  
Pressure: 0~10Bar  
Temperature: 5~60  
Material: Aluminium

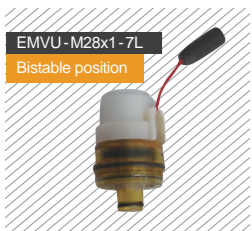

**Model:** EMVU-M28x1-7L  
Port Size: M28x1  
Orifice: 7mm  
Min: 0.5Bar  
Max(water): 8Bar  
Max Tem: 60  
Dimensions: 28.6\*28.6\*48.5

Bistable position

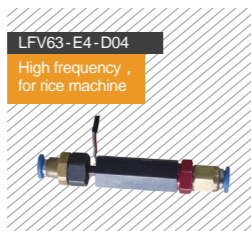

**Model:** LfV63-E4-D04  
OD.Tabe: 4mm  
Orifice: 0.5~1mm  
Min: 1Bar  
Max(water): 4Bar  
Max Tem: 50  
Dimensions: 77.6\*51.3\*51.3

High frequency, for rice machine

E.MC applies plenty of patent rights for the specially designed solenoid valves, of which some are 1st products in China pneumatic industry. Just Let us know what you want, and E.MC will develop the exact product with in 50 days.

## Connector

43650A  
Type  
A: DIN43650 A (ISO4400)  
B: DIN43650 B (Industrial)  
C: DIN43650 C (Industrial)

**A** - 1  
Power Voltage  
type: 1 : 12V-48V  
A: AC 2 : 110V-220V  
D: DC 3 : 380V

**B** - **E**  
Blank: Not with "EMC" logo  
E: With "EMC" logo  
Note: can make with customer's logo

Cover color:  
T: Colorless and transparent  
C: Brown translucent  
B: Black opaque

**L** - **R**  
Blank: not with LED lamp  
L: with LED lamp  
Note: DC current is with colorless and transparent lamp, with green light when power on. If wrong wiring with red light  
AC current is with red lamp and with red light if be power on.

**R**  
Piezoresistor  
Blank: without piezoresistor  
R: with piezoresistor  
Note: Only DIN43650B can with piezoresistor

### Order example:

DIN43650 industrial B type, AC220V, colorless and transparent cover, not with EMC logo, with LED lamp, with piezoresistor. Item No.: 43650B-A2TLR



## Armature+connector+timer

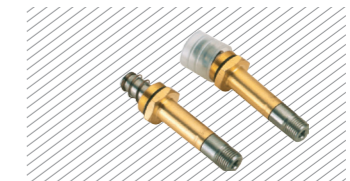
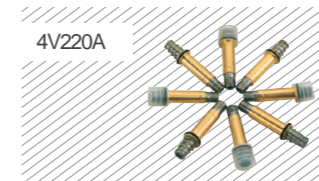
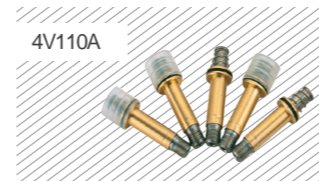

We can produce many Special products based on clients' requirement

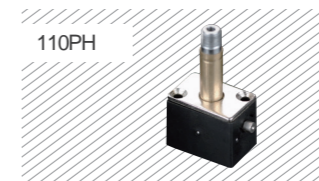

## Coil

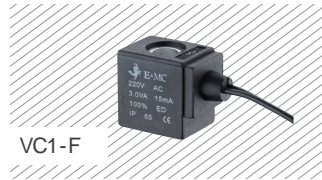

VC1-F

For:V5211  
Orifice(mm): 8  
Size(mm):22(L)x17(W)x23.5(H)



VC1-DT

For:V5211  
Orifice(mm): 8  
Size(mm):22(L)x17(W)x23.5(H)



VC2-DT

For:V5221, V5231, V5241  
Orifice(mm): 9.2  
Size(mm):28.5(L)x22(W)x29(H)

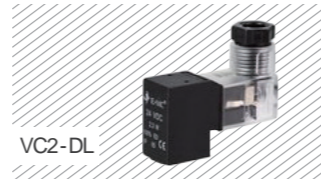

VC2-DL

For:2.3W 24VDC  
Orifice(mm): 9.2  
Size(mm):15(L)x20.5(W)x26(H)

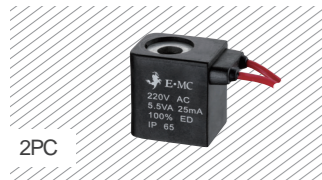

2PC

For:2P025 / V5221 / V5231 / V5241  
Orifice(mm): 9.2  
Size(mm):29(H)



2VC

For:2V6-25  
Orifice(mm): 9  
Size(mm):29(H)



VXC

For:VX06-15  
Orifice(mm): 11  
Size(mm):35(H)



SLG54 04C-D

For:SLG540415-25D  
Orifice(mm): 16.3  
Size(mm):41.4(L)x39.4(W)x79.5(H)



SLP-HC

For:SLP10-50(N.O.)  
Orifice(mm): 16.3  
Size(mm):54(L)x38.5(W)x40(H)



SLPC

For:3-50mm, EV1/EV3/ EV5, ZS 10  
Orifice(mm): 14.7  
Size(mm):38.5(L)x29(W)x42(H)

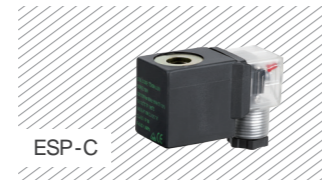

ESP-C

For:ESP10-40mm  
Orifice(mm): 13  
Size(mm):40(H)

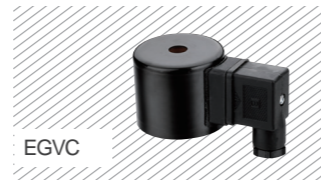

EGVC

EGVC-1 For:3mm  
Orifice(mm): 13.7  
Size(mm):34(H)  
EGVC-2 For:25mm  
Orifice(mm): 16.3  
Size(mm):41(H)



ZSC-1D

For:ZS10-25mm(N.C.) / THP(N.C.,N.O.)  
SLP15-50(N.O.)  
Orifice(mm): 16.3  
Size(mm):54(L)x38.5(W)x40(H)

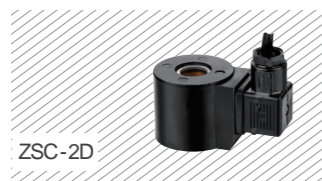

ZSC-2D

For:ZS32-50mm  
Orifice(mm): 20.3  
Size(mm):50(H)



ZSC-1F

For:ZS4-25mm  
Orifice(mm): 16.3  
Size(mm):54(L)x38.5(W)x40(H)

Complete automatic winding machine; Pins silver plated;  
Super low power optional for all DIN coil  
Breakdown test at 2000V; H class high temperature coil  
optional; Available with customized design

EGVC-3 For:32-50mm  
Orifice(mm): 20.3  
Size(mm):61.5(H)  
EGVC-4 For:32-50mm  
(DC12V,DC24V)  
Orifice(mm): 20.3  
Size(mm):61.5(H)

## Coil



EWC

For:EWSLC  
Orifice(mm): 11.5  
Size(mm):34(H)



VEC

For:V5221/ V5231/ V5241  
Orifice(mm): 9.2  
Size(mm):29(H)



UWEC

For:UW Series  
Orifice(mm): 16  
Size(mm):31(H)

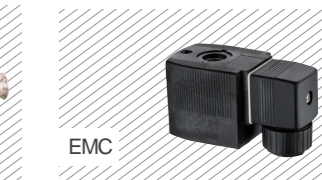

EMC

EMC-1C  
For:EMC08B / 010B / 015B / 025B  
EMC22001-3232 / 002 / 003/  
EMC23  
Orifice(mm): 12  
Size(mm):42(L)x36(W)x40(H)

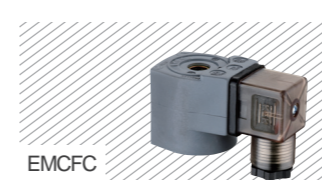

EMCFC

For:EMCF type pulse valve  
Orifice(mm): 12.3  
Size(mm):42.5(L)x37.5(W)x41.5(H)



EMB-C

For:EMB23 valve  
Orifice(mm): 11.5  
Size(mm):30(L)x30(W)x47(H)



ESV-C

For:ESV06/ ESV08  
Orifice(mm): 14.5  
Size(mm):38.5(L)x29(W)x42(H)

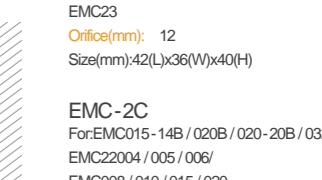

EMC-2C

For:EMC015-14B / 020B / 020-20B / 032B  
EMC22004 / 005 / 006/  
EMC008 / 010 / 015 / 020  
EMC23 / AC24V  
Orifice(mm): 14.5  
Size(mm):42(L)x36(W)x40(H)

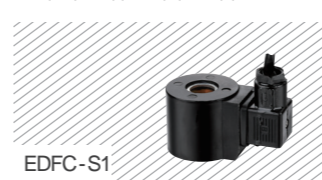

EDFC-S1

For:EDF15-20mm  
Orifice(mm): 16.3  
Size(mm):43.5(H)



EDFC-B2

For:EDF32-50  
Orifice(mm): 21  
Size(mm):55.5(H)



PUC

For:PU15-20  
Orifice(mm): 14  
Size(mm):42(H)

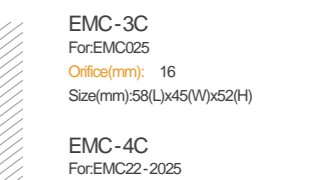

EMC-3C

For:EMC025  
Orifice(mm): 16  
Size(mm):58(L)x45(W)x52(H)



UWC-1

For:UW10-25  
Orifice(mm): 16  
Size(mm):37(H)



Q23C

For:Q23XD  
Orifice(mm): 19  
Size(mm):33(H)



USC

For:UW35-50/ US10-50  
Orifice(mm): 23  
Size(mm):55(H)



UDC

For:UD6-8/EV2/EV4  
Orifice(mm): 14  
Size(mm):31(H)



CORE PRODUCT >>

### >> Air filter, regulator and lubricator

- Maximized flow with enlarged filtering area on filter element
- Diaphragm structure, with suitable spring force after trial and demonstration, to make sure best regulator pressure performance
- Special structure design of lubricator, oil adding at any time without stopping working
- Wide application with polycarbonate water and coil cup
- The updated E/EI series FRL, with E-MC engineers deep study, test and special body design, it supports more than 9 Bar in actual application while normal FRL oilers break for long time use, which proves top technology in FRL field and give a better air source solution for higher pressure demanded fields.

## EI Series Air Source Treatment Unit

### How to Order?

#### Order Example:

- EI series,F+R+L,3000 Body Size,Port Size:3/8",Manual DrainType,Model:EIC3000-03
- EI series,F+R+L,3000 Body Size,Port Size:3/8", Two Units,Auto DrainType,Model:EIC3010-03D
- EI series,F+R,3000 Body Size,Port Size:3/8",Manual DrainType,Model:EIW3000-03
- EI series,Filter,3000 Body Size,Port Size:3/8",Auto DrainType,Model:EIF3000-03D
- EI series,Lubricator,3000 Body Size,Port Size:3/8",Model:EIL3000-03
- EI series,Regulator,3000 Body Size,Port Size:3/8",Model:EIR3000-03



Model  
EIC2000-01  
EIC2000-02



Model  
EIC3000-02  
EIC3000-03  
EIC4000-04  
EIC5000-06  
EIC5000-10



Model  
EIC2010-01  
EIC2010-02



Model  
EIC3010-02  
EIC3010-03  
EIC4010-04  
EIC5010-06  
EIC5010-10



Model  
EIW2000-01  
EIW2000-02



Model  
EIW3000-02  
EIW3000-03  
EIW4000-04  
EIW5000-06  
EIW5000-10



Model  
EIL2000-01  
EIL2000-02



Model  
EIL3010-02  
EIL3010-03  
EIL4010-03  
EIL4010-04  
EIL5010-06  
EIL5010-10



Model  
EIF2000-01  
EIF2000-02



Model  
EIF3000-02  
EIF3000-03  
EIF4000-03  
EIF4000-04  
EIF5000-06  
EIF5000-10



Model  
EIR2000-01  
EIR2000-02  
EIR3000-02  
EIR3000-03  
EIR4000-04  
EIR5000-06  
EIR5000-10

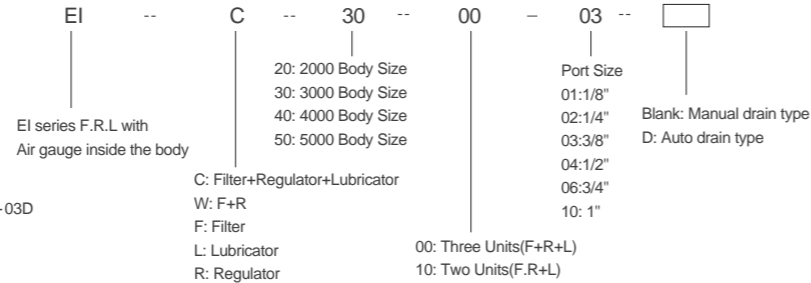

Note: Standard with 25 micron filtration, 5 micron optional.

## E Series Air Source Treatment Unit

### How to Order?

#### Order Example:

- E series,F+R+L,3000 Body Size,Port Size:3/8",Manual DrainType,Model:EC3000-03
- E series,F+R+L,3000 Body Size,Port Size:3/8",Auto DrainType,Model:EC3010-03D
- E series,F+R,3000 Body Size,Port Size:3/8",Manual DrainType,Model:EW3000-03
- E series,Filter,3000 Body Size,Port Size:3/8",Auto DrainType,Model:EF3000-03D
- E series,Lubricator,3000 Body Size,Port Size:3/8",Model:EL3000-03
- E series,Regulator,3000 Body Size,Port Size:3/8",Model:ER3000-03

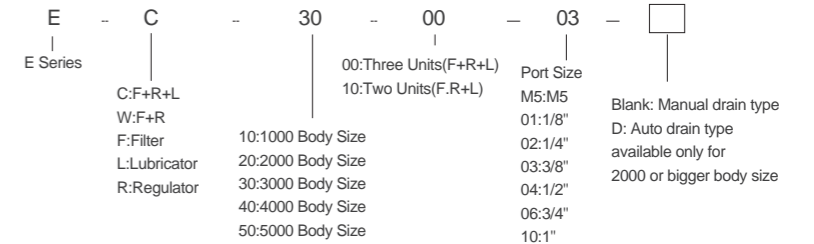

Model  
EC1000-M5  
EC2000-01  
EC2000-02



Model  
EC2500-02  
EC2500-03  
EC3000-02  
EC3000-03  
EC4000-03  
EC4000-04  
EC4000-06



Model  
EC5000-06  
EC5000-10



Model  
EW1000-W5  
EW2000-01  
EW2000-02



Model  
EC2010-M5  
EC2010-01  
EC2010-02



Model  
EC3010-02  
EC3010-03  
EC4010-03  
EC4010-04  
EC4010-06



Model  
EC5010-06  
EC5010-10



Model  
EW3000-02  
EW3000-03  
EW4000-03  
EW4000-04  
EW4000-06



Model  
EL1000-M5  
EL2000-01  
EL2000-02



Model  
EL3000-02  
EL3000-03  
EL4000-03  
EL4000-04  
EL4000-06



Model  
EL5000-06  
EL5000-10



Model  
EW5000-06  
EW5000-10



Model  
EF1000-M5  
EF2000-01  
EF2000-02



Model  
EF3000-02D  
EF3000-03D  
EF4000-03D  
EF4000-04D  
EF4000-06D



Model  
EF3000-02  
EF3000-03  
EF4000-03  
EF4000-04  
EF4000-06



Model  
EF5000-06  
EF5000-10



Model  
ER1000-M5 ER2000-01  
ER2000-02 ER2500-02  
ER2500-03 ER3000-02  
ER3000-03 ER4000-03  
ER4000-04 ER4000-06  
ER5000-06 ER5000-10

## FE Series Air Source Treatment Unit

### How to Order?

#### Order Example:

FE Series, F+R+L, M5 connection size, metal design, 5 μm precision, MICRO type with semi autodrain, Model: FEC-M5-D-5M-MICRO-H  
 FE Series, Regulator, G1/8" connection size, metal design, MINI type, Model: FER-1/8-D-MINI  
 FE Series, Lubricator, G1/4" connection size, metal design, MINI type, Model: FEL-1/4-D-MINI

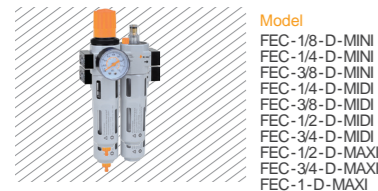
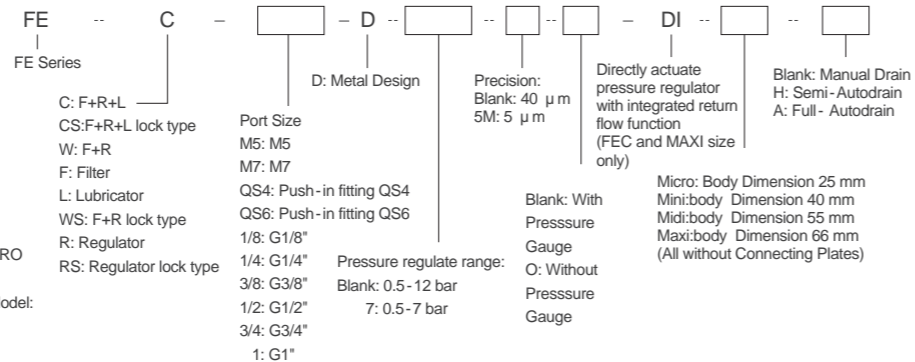

**Model**  
 FEC-1/8-D-MINI  
 FEC-1/4-D-MINI  
 FEC-3/8-D-MINI  
 FEC-1/4-D-MIDI  
 FEC-3/8-D-MIDI  
 FEC-1/2-D-MIDI  
 FEC-3/4-D-MIDI  
 FEC-1/2-D-MAXI  
 FEC-3/4-D-MAXI  
 FEC-1-D-MAXI

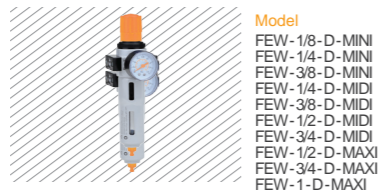

**Model**  
 FEW-1/8-D-MINI  
 FEW-1/4-D-MINI  
 FEW-3/8-D-MINI  
 FEW-1/4-D-MIDI  
 FEW-3/8-D-MIDI  
 FEW-1/2-D-MIDI  
 FEW-3/4-D-MIDI  
 FEW-1/2-D-MAXI  
 FEW-3/4-D-MAXI  
 FEW-1-D-MAXI

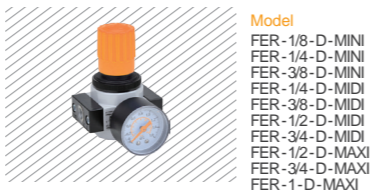

**Model**  
 FER-1/8-D-MINI  
 FER-1/4-D-MINI  
 FER-3/8-D-MINI  
 FER-1/4-D-MIDI  
 FER-3/8-D-MIDI  
 FER-1/2-D-MIDI  
 FER-3/4-D-MIDI  
 FER-1/2-D-MAXI  
 FER-3/4-D-MAXI  
 FER-1-D-MAXI

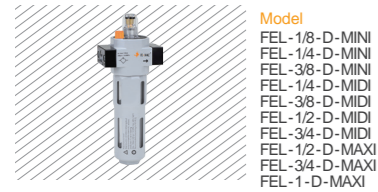

**Model**  
 FEL-1/8-D-MINI  
 FEL-1/4-D-MINI  
 FEL-3/8-D-MINI  
 FEL-1/4-D-MIDI  
 FEL-3/8-D-MIDI  
 FEL-1/2-D-MIDI  
 FEL-3/4-D-MIDI  
 FEL-1/2-D-MAXI  
 FEL-3/4-D-MAXI  
 FEL-1-D-MAXI

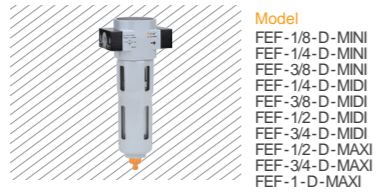

**Model**  
 FEF-1/8-D-MINI  
 FEF-1/4-D-MINI  
 FEF-3/8-D-MINI  
 FEF-1/4-D-MIDI  
 FEF-3/8-D-MIDI  
 FEF-1/2-D-MIDI  
 FEF-3/4-D-MIDI  
 FEF-1/2-D-MAXI  
 FEF-3/4-D-MAXI  
 FEF-1-D-MAXI

### How to Order?

ERH Series High Pressure Regulator  
 Pressure: 0.5-35Bar

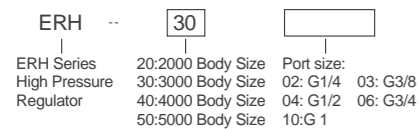

**Model**  
 ERH20-02 ERH30-03  
 ERH40-04 ERH50-06  
 ERH50-10

EFRH Series High Pressure Filter&Regulator  
 Pressure: 1.5-35Bar

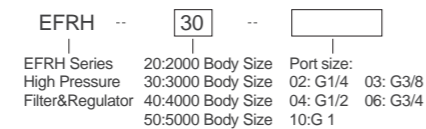

**Model**  
 EFRH20-02 EFRH30-03  
 EFRH40-04 EFRH50-06  
 EFRH50-10

ELH Series High Pressure Filter  
 Pressure: 1.5-4Bar

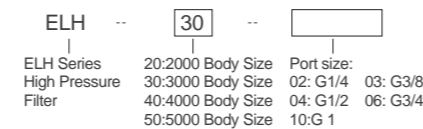

**Model**  
 ELH20-02 ELH30-03  
 ELH40-04 ELH50-06  
 ELH50-10

## FEO Series Mini Air Source Treatment Unit

### How to Order?

#### Order Example:

FEO Series, Filter, Regulaor, Lubricator, M5, 5 μm pressure gauge, MICRO, manual drain type, Model: FEOC-M5-5M-MICRO  
 FEO Series, Filter, Regulaor, M7, 5 μm pressure gauge, MICRO, manual drain type, Model: FEOW-M7-5M-MICRO  
 FEO Series, Lubricator, G1/8", 5 μm pressure gauge, MICRO, turned manually, Model: FEOL-1/8-5M-MICRO

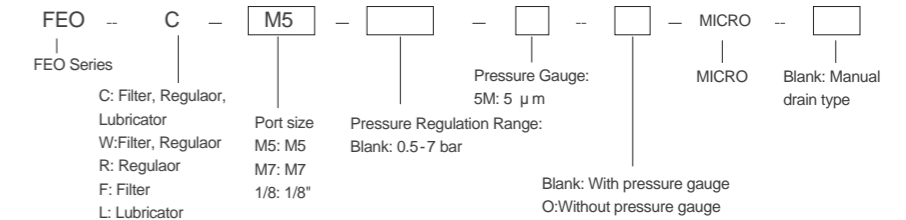

**Model**  
 FEOC-M5-5M-MICRO  
 FEOC-M7-5M-MICRO  
 FEOC-1/8-5M-MICRO



**Model**  
 FEOW-M5-5M-MICRO  
 FEOW-M7-5M-MICRO  
 FEOW-1/8-5M-MICRO



**Model**  
 FEOR-M5-5M-MICRO  
 FEOR-M7-5M-MICRO  
 FEOR-1/8-5M-MICRO



**Model**  
 FEOF-M5-5M-MICRO  
 FEOF-M7-5M-MICRO  
 FEOF-1/8-5M-MICRO



**Model**  
 FEOL-M5-5M-MICRO  
 FEOL-M7-5M-MICRO  
 FEOL-1/8-5M-MICRO

## FRL Pressure Sensor

Model No.	EPSH-02
Working Medium	Air
Max. Pressure	7Bar
Pressure Regulation Range	1-4Bar
Legging	0.8Bar
Working Temperature	-5-60



## HE Series Air Source Treatment Unit

### How to Order?

#### Order Example:

HE Series,F+R+L,3000 Body Size,Port Size:3/8",Manual DrainType,Model:HEC3000-03  
 HE Series,F+R+L,3000 Body Size,Port Size:3/8",Auto DrainType,Model:HEC3010-03D  
 HE Series,F+R,3000 Body Size,Port Size:3/8",Manual DrainType,Model:HEW3000-03  
 HE Series,Filter,3000 Body Size,Port Size:3/8",Auto DrainType,Model:HEF3000-03D  
 HE Series,Lubricator,3000 Body Size,Port Size:3/8",Model:HEL3000-03

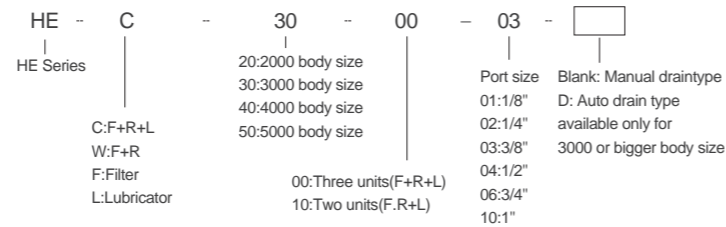

Model  
HEC2000-01  
HEC2000-02



Model  
HEC3000-02  
HEC3000-03  
HEC4000-04  
HEC4000-05  
HEC4000-06



Model  
HEC5000-06  
HEC5000-10



Model  
HEW2000-01  
HEW2000-02



Model  
HEC2010-01  
HEC2010-02



Model  
HEC3010-02  
HEC3010-03  
HEC4010-03  
HEC4010-04  
HEC4010-05  
HEC4010-06



Model  
HEC5010-06  
HEC5010-10



Model  
HEW3000-02  
HEW3000-03  
HEW4000-04  
HEW4000-05  
HEW4000-06



Model  
HEF2000-01  
HEF2000-02



Model  
HEF3000-02  
HEF3000-03  
HEF4000-04  
HEF4000-05  
HEF4000-06



Model  
HEF5000-06  
HEF5000-10



Model  
HEW5000-06  
HEW5000-10



Model  
HEL2000-01  
HEL2000-02



Model  
HEL3000-02  
HEL3000-03  
HEL4000-03  
HEL4000-04  
HEL4000-05  
HEL4000-06



Model  
HEL5000-06  
HEL6000-10



Model  
HR2000-01 HR2000-02  
HR3000-02 HR3000-03  
HR4000-03 HR4000-04  
HR4000-06 HR5000-06  
HR5000-10

## HNE Series Air Source Treatment Unit

### How to Order?

#### Order Example:

HNE Series,F+R+L,3000 Body Size,Port Size:3/8",Manual DrainType,Model:HNEC3000-03  
 HNE Series,F+R+L,3000 Body Size,Port Size:3/8",Auto DrainType,Model:HNEC3010-03D  
 HNE Series,F+R,3000 Body Size,Port Size:3/8",Manual DrainType,Model:HNEW3000-03  
 HNE Series,Filter,3000 Body Size,Port Size:3/8",Auto DrainType,Model:HNEF3000-03D  
 HNE Series,Lubricator,3000 Body Size,Port Size:3/8",Model:HNEL3000-03

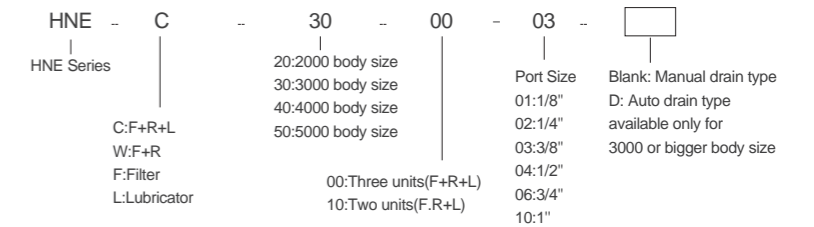

Model  
HNEC2000-01  
HNEC2000-02



Model  
HNEC3000-02  
HNEC3000-03  
HNEC4000-04  
HNEC4000-05  
HNEC4000-06



Model  
HNEC5000-06  
HNEC5000-10



Model  
HNEW2000-01  
HNEW2000-02



Model  
HNEC2010-01  
HNEC2010-02



Model  
HNEC3010-02  
HNEC3010-03  
HNEC4010-04  
HNEC4010-05  
HNEC4010-06



Model  
HNEC5010-06  
HNEC5010-10



Model  
HNEW3000-02  
HNEW3000-03  
HNEW4000-04  
HNEW4000-05  
HNEW4000-06



Model  
HNEF2000-01  
HNEF2000-02



Model  
HNEF3000-02  
HNEF3000-03  
HNEF4000-04  
HNEF4000-05  
HNEF4000-06



Model  
HNEF5000-06  
HNEF5000-10



Model  
HNEW5000-06  
HNEW5000-10



Model  
HNEL2000-01  
HNEL2000-02



Model  
HNEL3000-02  
HNEL3000-03  
HNEL4000-04  
HNEL4000-05  
HNEL4000-06



Model  
HNEL5000-06  
HNEL5000-10



Model  
ER2000-01 ER2000-02  
ER3000-02 ER3000-03  
ER4000-03 ER4000-04  
ER4000-06 ER5000-06  
ER5000-10



## Bracket

T-Type Spacer



**Model:**  
Y21-01 Y21-02 Y31-01 Y31-02 Y41-02  
Y41-03 Y61-03 Y61-04  
**Applicable Model:**  
EC2000 EC3000 EC4000 EC5000

Spacer with L-Type Bracket



**Model:**  
Y10L Y20L Y30L Y40L Y50L Y60L  
**Applicable Model:**  
EC1000 EC2000 EC2500/3000  
EC4000 EC4000-06 EC5000

L-Type Bracket



**Model:**  
B110L B210L B310L B410L B510L B610L  
**Applicable Model:**  
EC1000 EC2000 EC2500/3000  
EC4000 EC4000-06 EC5000

40-Type Bracket



**Model:**  
B240 B340 B440 B540 B640  
**Applicable Model:**  
EF2000 EL2000 EF3000 EL3000 EF4000  
EL4000 EF4000-06 EL4000-06 EF5000  
EL5000

Spacer with L-Type Bracket



**Model:**  
Y10T Y20T Y30T Y40T Y50T Y60T  
**Applicable Model:**  
EC1010 EC2010 EC3010 EC4010  
EC4010-06 EC5010

T-Type Bracket



**Model:**  
B110T B210T B310T B410T B510T B610T  
**Applicable Model:**  
EC1010 EC2010 EC2510/3010 EC4010  
EC4010-06 EC5010

20-Type Bracket



**Model:**  
B120 B220 B320 B420  
**Applicable Model:**  
ER1000 EW1000 ER2000/2500  
EW2000/2500 ER3000 EW3000  
ER4000/5000 EW4000/5000

Auto Drain Element



**Model:** ZDFS-06 ZDFS-08

40-Type Bracket



**Auto Drain:**  
HED402-02 HED402-03  
HED402-04

Auto Drain



**Model:**  
HAD402 1/2"

## AE Series Air Source Treatment Unit

### How to Order?

#### Order Example:

AE series , Filter+Regulator+Lubricant , Port Size: 1/4", Model:AEC2000

### Specifications

Working Press.:0.5—10Bar  
Max.Press:15Bar  
Working Temp.:5-60  
Filter Precision: 40 μ (25 μ , 5 μ is optional)

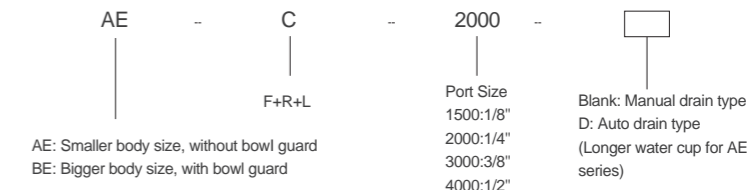

**Model**  
AEC2000  
400L/min



**Model**  
BEC2000  
3500L/min  
BEC3000  
3500L/min  
BEC4000  
3500L/min



**Model**  
AEFC2000  
400L/min



**Model**  
BEFC2000  
2500L/min  
BEFC3000  
2500L/min  
BEFC4000  
2500L/min



**Model**  
AEF2000  
700L/min



**Model**  
BEF2000  
3500L/min  
BEF3000  
3500L/min  
BEF4000  
3500L/min



**Model**  
AEL2000  
700L/min



**Model**  
BEL2000  
4500L/min  
BEL3000  
4500L/min  
BEL4000  
4500L/min



**Model**  
AER2000 500L/min  
AER2000 4500L/min  
AER3000 4500L/min  
AER4000 4500L/min



**Model**  
AER2000 500L/min  
BER2000 4500L/min  
BER3000 4500L/min  
BER4000 4500L/min

## EA Series Air Source Treatment Unit

Working Pressure: 0.5-17Bar



Model  
EAF3000-02

Model  
EAL3000-02

Model  
EAF3000-02

## EN Series Air Source Treatment Unit

Working Pressure: 0.5-8Bar



Model  
ENF2000-02

Model  
ENW2000-02

Model  
ENF2000-02

Model  
ENR2000-02

Model  
ENL2000-02

## Muffler

Working Pressure: 0-10Bar

### A Type Muffler

Model	Size	Thread	S
A-M5	M5	8	9
A-6A	1/8"	13	
A-8A	1/4"	17	
A-10A	3/8"	22	
A-15A	1/2"	24	
A-20A	3/4"	30	
A-25A	1"	36	
A-32A	1 1/4"	46	
A-40A	1 1/2"	52	
A-50A	2"	64	

### AP Type PE Muffler

Model	Size	Thread	S
AP-6	1/8"	13	
AP-8	1/4"	17	
AP-10	3/8"	22	
AP-15	1/2"	24	
AP-20	3/4"	30	
AP-25	1"	36	

### AS Type Muffler Steel with Nickel

Model	Size	Thread	S
AS-2.5	10-32UNF	8	
AS-6	1/8"	11	
AS-8	1/4"	14	
AS-10	3/8"	17	
AS-15	1/2"	22	
AS-20	3/4"	27	
AS-25	1"	34	
AS-32	1-1/4"	43	
AS-40	1-1/2"	51	

### SET Type S.S Muffler

Model	Size	Thread	S
SET-7	1/8"	8	
SET-9.5	1/4"	10	
SET-12.5	3/8"	13	
SET-15.5	1/2"	15	
SET-22	3/4"	19	
SET-28	1"	24	

### AAS Type S.S Muffler

Model	Size	Thread	S
AAS-M5	M5	8	
AAS-6	1/8"	12	
AAS-8	1/4"	15	
AAS-10	3/8"	19	
AAS-15	1/2"	23	
AAS-20	3/4"	30	
AAS-25	1"	36	

### V Type S.S Muffler

Model	Size	Thread	S
V-M5	M5	8	
V-6	1/8"	12	
V-8	1/4"	15	
V-10	3/8"	19	
V-15	1/2"	23	
V-20	3/4"	30	
V-25	1"	36	

### AB Type Muffler

Model	Size	Thread	S
AB-6	1/8"	11	
AB-8	1/4"	14	
AB-10	3/8"	17	
AB-15	1/2"	22	
AB-20	3/4"	27	
AB-25	1"	33	
AB-32	1 1/4"	43	
AB-40	1 1/2"	51	
AB-50	2"	60	

### SVF Type S.S Muffler

Model	Size	Thread	S
VF-M5	M5	8	
VF-6	1/8"	13	
VF-8	1/4"	16	
VF-10	3/8"	19	
VF-15	1/2"	24	

## E804 Series Air Source Treatment Unit

Working Pressure: 0.5-8Bar



Model  
EL804-02 EL804-03  
EL804-04

Model  
EFR804-02 EFR804-03  
EFR804-04

Model  
EFRL804-02 EFRL804-03  
EFRL804-04

## Muffler

Working Pressure: 0-10Bar

### VS Type Muffler Steel with Nickel Plated

Model	Size	Thread	S
VS-6	1/8"	11	
VS-8	1/4"	14	
VS-10	3/8"	17	
VS-15	1/2"	22	
VS-20	3/4"	27	
VS-25	1"	34	
VS-32	1-1/4"	43	
VS-40	1-1/2"	51	

### VT Type Muffler

Model	Size	Thread	S
VT-6	1/8"	12.5	
VT-8	1/4"	13.5	
VT-10	3/8"	16	
VT-15	1/2"	19.6	
VT-20	3/4"	23	
VT-25	1"	24	

### VD Type Muffler

Model	Size	Thread	S
VD-6	1/8"	12	
VD-8	1/4"	15	
VD-10	3/8"	19	
VD-15	1/2"	23	
VD-20	3/4"	30	
VD-25	1"	36	

### SK Type Muffler

Model	Size	Thread	S
SK-6	1/8"	16	
SK-8	1/4"	20	
SK-10	3/8"	24	
SK-15	1/2"	24	
SK-20	3/4"	48	
SK-25	1"	48	

### VDS Type S.S Muffler

Model	Size	Thread	S
VDS-M5	M5	8	
VDS-6	1/8"	13	
VDS-8	1/4"	16	
VDS-10	3/8"	19	
VDS-15	1/2"	24	
VDS-20	3/4"	30	
VDS-25	1"	36	

### PSU Type Muffler

Model	Size	Thread	S
PSU-6	1/8"	13	
PSU-8	1/4"	17	
PSU-10	3/8"	25	
PSU-15	1/2"	25	
PSU-20	3/4"	37	
PSU-25	1"	48	

### VSS Type S.S Muffler

Model	Size	Thread	S
VSS-M5	M5	8	
VSS-6	1/8"	13	
VSS-8	1/4"	16	
VSS-10	3/8"	19	
VSS-15	1/2"	24	
VSS-20	3/4"	30	
VSS-25	1"	36	

### PSE Type Muffler

Model	Size	Thread	S
PSE-M5	M5	7	
PSE-6	1/8"	13	
PSE-8	1/4"	17	
PSE-10	3/8"	25	
PSE-15	1/2"	25	
PSE-20	3/4"	37	
PSE-25	1"	48	

## Quick Exhaust Muffing Throttle Valve

Working Pressure: 0-10Bar

### SA Quick Exhaust Muffler Throttle Valve

Model	Size	Thread	S
VA-6	1/8"	13	
VA-8	1/4"	14	
VA-10	3/8"	17	
VA-15	1/2"	24	
VA-20	3/4"	27	
VA-25	1"	34	

### SK Quick Exhaust Muffler Throttle Valve

Model	Size	Thread	S
SK-6	1/8"	13	
SK-8	1/4"	14	
SK-10	3/8"	17	
SK-15	1/2"	24	
SK-20	3/4"	27	
SK-25	1"	34	

### SB Quick Exhaust Muffler Throttle Valve

Model	Size	Thread	S
SB-6	1/8"	13	
SB-8	1/4"	14	
SB-10	3/8"	17	
SB-15	1/2"	24	
SB-20	3/4"	27	
SB-25	1"	34	

### SS Quick Exhaust Muffler Throttle Valve

Model	Size	Thread	S
SKK-6	1/8"	13	
SKK-8	1/4"	14	
SKK-10	3/8"	17	
SKK-15	1/2"	24	
SKK-20	3/4"	27	
SKK-25	1"	34	

### SC Quick Exhaust Muffler Throttle Valve

Model	Size	Thread	S
SC-6	1/8"	13	
SC-8	1/4"	14	
SC-10	3/8"	17	
SC-15	1/2"	24	
SC-20	3/4"	27	
SC-25	1"	34	

### SPK Quick Exhaust Muffler Throttle Valve

Model	Size	Thread	S
SPK-6	1/8"	13	
SPK-8	1/4"	14	
SPK-10	3/8"	17	
SPK-15	1/2"	24	
SPK-20	3/4"	27	
SPK-25	1"	34	

### SD Quick Exhaust Muffler Throttle Valve

Model	Size	Thread	S
SD-6	1/8"	12	
SD-8	1/4"	15	
SD-10	3/8"	17	
SD-15	1/2"	24	
SD-20	3/4"	27	
SD-25	1"	34	



CORE PRODUCT >>

### >> Fitting

- Automatic mass production
- Automatic assembling and testing
- All parts self provided
- Sufficient types available for all your demands

One Touch-In Fitting Popular items

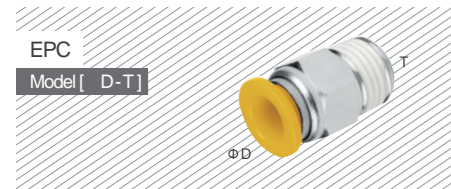

**Tube(Metric)-Thread(PT):** EPC04-M5 EPC04-M6 EPC04-01 EPC04-02 EPC06-M5 EPC06-M6 EPC06-01 EPC06-02 EPC06-03 EPC06-04 EPC08-01 EPC08-02 EPC08-03 EPC08-04 EPC10-01 EPC10-02 EPC10-03 EPC10-04 EPC12-02 EPC12-02 EPC12-03 EPC12-04 EPC14-03 EPC14-04 EPC16-03 EPC16-04  
**Tube(Inch)-Thread(PT):** EPC1/4-01 EPC1/4-02 EPC1/4-03 EPC5/16-01 EPC5/16-02 EPC5/16-03 EPC3/8-01 EPC3/8-02 EPC3/8-03 EPC3/8-04/EPC1/2-02 EPC1/2-03 EPC1/2-04

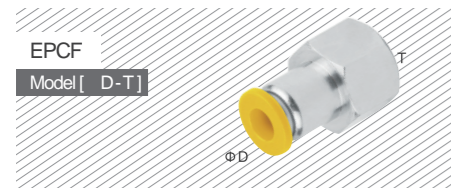

**Tube(Metric)-Thread(PT):** EPCF04-01 EPCF04-02 EPCF06-01 EPCF06-02 EPCF06-03 EPCF08-01 EPCF08-02 EPCF08-03 EPCF08-04 EPCF10-01 EPCF10-02 EPCF10-03 EPCF10-04 EPCF12-02 EPCF12-03 EPCF12-04 EPCF16-03 EPCF16-04  
**Tube(Inch)-Thread(PT):** EPCF1/4-01 EPCF1/4-02 EPCF5/16-01 EPCF5/16-02 EPCF3/8-02 EPCF3/8-03

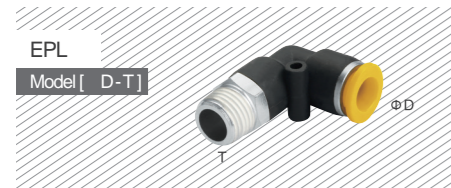

**Tube(Metric)-Thread(PT):** EPL04-05 EPL04-M6 EPL04-01 EPL04-02 EPL06-M5 EPL06-M6 EPL06-01 EPL06-02 EPL06-03 EPL06-04 EPL08-01 EPL08-02 EPL08-03 EPL08-04 EPL10-01 EPL10-02 EPL10-03 EPL10-04 EPL12-02 EPL12-03 EPL12-04 EPL14-03 EPL14-04 EPL16-03 EPL16-04  
**Tube(Inch)-Thread(PT):** EPL1/4-01 EPL1/4-02 EPL1/4-03 EPL5/16-01 EPL5/16-02 EPL5/16-03 EPL3/8-01 EPL3/8-02 EPL3/8-03 EPL3/8-04 EPL1/2-02 EPL1/2-03 EPL1/2-04



**Tube(Metric)-Thread(PT):** EPB04-M5 EPB04-M6 EPB04-01 EPB04-02 EPB06-M5 EPB06-M6 EPB06-01 EPB06-02 EPB06-03 EPB06-04 EPB08-01 EPB08-02 EPB08-03 EPB08-04 EPB10-01/EPB10-02 EPB10-03 EPB10-04 EPB12-02 EPB12-03 EPB12-04 EPB14-03 EPB14-04 EPB16-03 EPB16-04  
**Tube(Inch)-Thread(PT):** EPB1/4-01 EPB1/4-02 EPB1/4-03 EPB5/16-01 EPB5/16-02 EPB5/16-03 EPB3/8-01 EPB3/8-02 EPB3/8-03 EPB3/8-04 EPB1/2-02 EPB1/2-03/EPB1/2-04

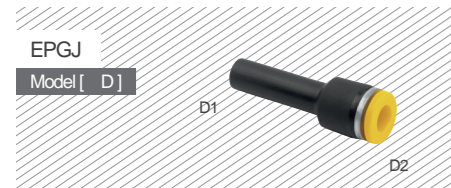

**Tube(Metric)-Thread(PT):** EPGJ06-04 EPGJ08-04 EPGJ08-06 EPGJ10-06 EPGJ10-08 EPGJ12-06 EPGJ12-08 EPGJ12-10  
**Tube(Inch)-Thread(PT):** EPGJ08-1/4 EPGJ10-1/4 EPGJ10-5/16 EPGJ12-1/4 EPGJ12-5/16

**Tube(Inch)-Thread(NPT):** EPC5/32-1/8"N EPC5/32-1/4"N EPC3/16-1/8"N EPC3/16-1/4"N EPC3/16-3/8"N EPC1/4-1/8"N EPC1/4-1/4"N EPC1/4-3/8"N EPC5/16-1/8"N EPC5/16-1/4"N EPC5/16-3/8"N EPC3/8-1/8"N EPC3/8-1/4"N EPC3/8-3/8"N EPC3/8-1/2"N EPC1/2-1/4"N EPC1/2-3/8"N EPC1/2-1/2"N

**Tube(Inch)-Thread(NPT):** EPCF5/32-1/8"N EPCF5/32-1/4"N EPCF3/16-1/8"N EPCF3/16-1/4"N EPCF1/4-1/8"N EPCF1/4-1/4"N EPCF5/16-1/8"N EPCF5/16-1/4"N EPCF5/16-3/8"N EPCF3/8-1/4"N EPCF3/8-3/8"N EPCF1/2-1/4"N EPCF1/2-3/8"N

**Tube(Inch)-Thread(NPT):** EPL5/32-1/8"N EPL5/32-1/4"N EPL3/16-1/8"N EPL3/16-1/4"N EPL3/16-3/8"N EPL1/4-1/8"N EPL1/4-1/4"N EPL1/4-3/8"N EPL5/16-1/8"N EPL5/16-1/4"N EPL5/16-3/8"N EPL3/8-1/8"N EPL3/8-1/4"N EPL3/8-3/8"N EPL3/8-1/2"N EPL1/2-1/4"N EPL1/2-3/8"N EPL1/2-1/2"N

**Tube(Inch)-Thread(NPT):** EPB5/32-1/8"N EPB5/32-1/4"N EPB3/16-1/8"N EPB3/16-1/4"N EPB3/16-3/8"N EPB1/4-1/8"N EPB1/4-1/4"N EPB1/4-3/8"N EPB5/16-1/8"N EPB5/16-1/4"N EPB5/16-3/8"N EPB3/8-1/8"N EPB3/8-1/4"N EPB3/8-3/8"N EPB3/8-1/2"N EPB1/2-1/4"N EPB1/2-3/8"N EPB1/2-1/2"N

**Tube(Inch)-Thread(NPT):** EPGJ5/16-5/32 EPGJ5/16-1/4

One Touch-In Fitting Popular items

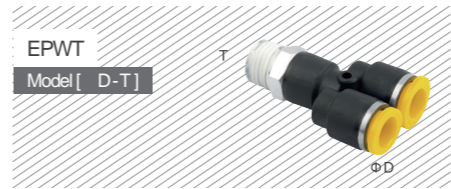

**Tube(Metric)-Thread(PT):** EPWT04-M5 EPWT04-M6 EPWT04-01 EPWT04-02 EPWT06-M5 EPWT06-M6 EPWT06-01 EPWT06-02 EPWT06-03 EPWT06-04 EPWT08-01 EPWT08-02 EPWT08-03 EPWT08-04 EPWT10-01 EPWT10-02 EPWT10-03 EPWT06-04 EPWT12-02 EPWT12-03 EPWT12-04  
**Tube(Inch)-Thread(PT):** EPWT1/4-01 EPWT1/4-02 EPWT1/4-03 EPWT5/16-01 EPWT5/16-02 EPWT5/16-03 EPWT3/8-01 EPWT3/8-02 EPWT3/8-03 EPWT3/8-04 EPWT1/2-02 EPWT1/2-03 EPWT1/2-04



**Tube(Metric)-Thread(PT):** ESC04-M5 ESC04-01 ESC04-02 ESC06-M5 ESC06-01 ESC06-02 ESC06-03 ESC06-04 ESC08-01 ESC08-02 ESC08-03 ESC08-04 ESC10-01 ESC10-02 ESC10-03 ESC10-04 ESC12-02 ESC12-03 ESC12-04  
**Tube(Inch)-Thread(PT):** ESC1/4-M5 ESC1/4-01 ESC1/4-02 ESC5/16-01 ESC5/16-02 ESC5/16-03 ESC3/8-02 ESC3/8-03

**Tube(Inch)-Thread(NPT):** EPWT5/32-1/8"N EPWT5/32-1/4"N EPWT5/32-1/4"N EPWT3/16-1/8"N EPWT3/16-1/4"N EPWT3/16-3/8"N EPWT1/4-1/8"N EPWT1/4-1/4"N EPWT1/4-3/8"N EPWT5/16-1/8"N EPWT5/16-1/4"N EPWT5/16-3/8"N EPWT3/8-1/8"N EPWT3/8-1/4"N EPWT3/8-3/8"N EPWT3/8-1/2"N EPWT1/2-1/4"N EPWT1/2-3/8"N EPWT1/2-1/2"N

**Tube(Inch)-Thread(NPT):** ESC5/32-U ESC5/32-N1 ESC3/16-U ESC3/16-N1 ESC3/16-N2 ESC3/16-N3 ESC1/4-U ESC1/4-N1 ESC1/4-N2 ESC1/4-N3 ESC5/16-N1 ESC5/16-N2 ESC5/16-N3 ESC5/16-N4 ESC3/8-N2 ESC3/8-N3 ESC3/8-N4 ESC1/2-N3 ESC1/2-N4



**Tube(Metric):** EPU04 EPU06 EPU08 EPU10 EPU12 EPU14 EPU16  
**Tube(Inch):** EPU5/32 EPU3/16 EPU1/4 EPU5/16 EPU3/8 EPU1/2



**Tube(Metric):** EPY04 EPY06 EPY08 EPY10 EPY12  
**Tube(Inch):** EPY5/32 EPY3/16 EPY1/4 EPY5/16 EPY3/8 EPY1/2



**Tube(Metric):** EPV04 EPV06 EPV08 EPV10 EPV12 EPV14 EPV16  
**Tube(Inch):** EPV5/32 EPV3/16 EPV1/4 EPV5/16 EPV3/8 EPV1/2

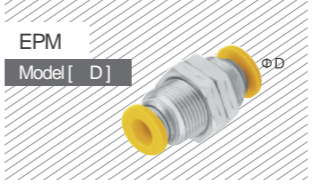

**Tube(Metric):** EPM04 EPM06 EPM08 EPM10 EPM12 EPM14 EPM16  
**Tube(Inch):** EPM5/32 EPM3/16 EPM1/4 EPM5/16 EPM3/8 EPM1/2



**Tube(Metric):** EPE04 EPE06 EPE08 EPE10 EPE12 EPE14 EPE16  
**Tube(Inch):** EPE5/32 EPE3/16 EPE1/4 EPE5/16 EPE3/8 EPE1/2

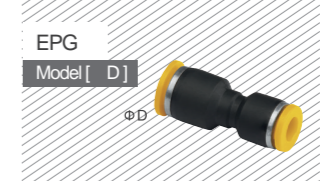

**Tube(Metric):** EPG06-04 EPG08-04 EPG08-06 EPG10-06 EPG10-08 EPG12-10 EPG16-12 EPG16-14  
**Tube(Inch):** EPG3/16-5/32 EPG1/4-5/32 EPG1/4-3/16 EPG5/16-1/4 EPG3/8-5/16 EPG1/2-3/8

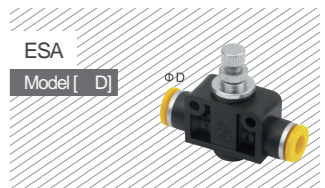

**Tube(Metric):** ESA04 ESA06 ESA08 ESA10 ESA12  
**Tube(Inch):** ESA5/32 ESA3/16/ ESA1/4 ESA5/16 ESA3/8 ESA1/2

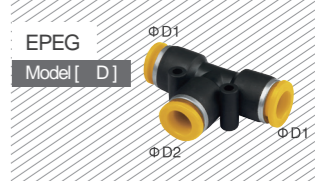

**Tube(Metric):** EPEG06-04 EPEG08-06 EPEG10-08 EPEG12-10 EPEG16-12  
**Tube(Inch):** EPEG1/4-5/32 EPEG5/16-1/4 EPEG3/8-5/16 EPEG1/2-3/8

One Touch-In Fitting General items

EPLF

Model [ D-T ]



**Tube(Metric)-Thread(PT):** EPLF04-M5 EPLF04-M6 EPLF04-01 EPLF04-02 EPLF06-M5 EPLF06-M6 EPLF06-01 EPLF06-02 EPLF06-03 EPLF08-01 EPLF08-02 EPLF08-03 EPLF08-04 EPLF10-01 EPLF10-02 EPLF10-03 EPLF10-04 EPLF02-02 EPLF12-03 EPLF12-04 EPLF14-03 EPLF14-04 EPLF16-03 EPLF16-04

EPLL

Model [ D-T ]



**Tube(Metric)-Thread(PT):** EPLL04-M5 EPLL04-M6 EPLL04-01 EPLL04-02 EPLL06-M5 EPLL06-M6 EPLL06-01 EPLL06-02 EPLL06-03 EPLL06-04 EPLL08-01 EPLL08-02 EPLL08-03 EPLL08-04 EPLL10-01 EPLL10-02 EPLL10-03 EPLL10-04 EPLL12-02 EPLL12-03 EPLL12-04 EPLL14-03 EPLL14-04 EPLL16-03 EPLL16-04  
**Tube(Inch)-Thread(PT):** EPLL1/4-01 EPLL1/4-02 EPLL5/16-02 EPLL3/8-02 EPLL3/8-03

EPLH

Model [ D-T ]

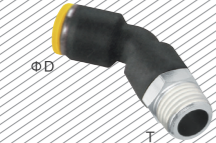

**Tube(Metric)-Thread(PT):** EPLH04-01 EPLH04-02 EPLH06-01 EPLH06-02 EPLH06-03 EPLH06-04 EPLH08-01 EPLH08-02 EPLH08-03 EPLH08-04 EPLH10-01 EPLH10-02 EPLH10-03 EPLH10-04 EPLH12-02 EPLH12-03 EPLH12-04

EPOC

Model [ D-T ]



**Tube(Metric)-Thread(PT):** EPOC04-M5 EPOC04-M6 EPOC04-01 EPOC04-02 EPOC06-M5 EPOC06-M6 EPOC06-01 EPOC06-02 EPOC06-03 EPOC08-01 EPOC08-02 EPOC08-03 EPOC08-04 EPOC10-01 EPOC10-02 EPOC10-03 EPOC10-04 EPOC12-02 EPOC12-03 EPOC12-04 EPOC14-03 EPOC14-04 EPOC16-03 EPOC16-04  
**Tube(Inch)-Thread(PT):** EPOC1/4-01 EPOC1/4-02/EPOC5/16-01 EPOC5/16-02 EPOC5/16-03 EPOC3/8-02 EPOC3/8-03 EPOC3/8-04

EPMF

Model [ D-T ]



**Tube(Metric)-Thread(PT):** EPMF04-01 EPMF04-02 EPMF06-01 EPMF06-02 EPMF06-03 EPMF08-01 EPMF08-02 EPMF08-03 EPMF08-04 EPMF08-05 EPMF10-01 EPMF10-02 EPMF10-03 EPMF10-04 EPMF12-02 EPMF12-03 EPMF12-04 EPMF14-04 EPMF16-04

**Tube(Inch)-Thread(NPT):** EPLF5/32-1/8"N EPLF3/16-1/8"N EPLF3/16-1/4"N EPLF1/4-1/8"N EPC F1/4-1/4"N EPLF5/16-1/8"N EPLF5/16-1/4"N EPLF5/16-3/8"N EPLF3/8-1/4"N EPLF3/8-3/8"N EPLF1/2-3/8"N EPLF1/2-1/2"N

**Tube(Inch)-Thread(NPT):** EPLL5/32-1/8"N EPLL3/16-1/8"N EPLL3/16-1/4"N EPLL3/16-3/8"N EPLL1/4-1/8"N EPLL1/4-1/4"N EPLL1/4-3/8"N EPLL5/16-1/8"N EPLL5/16-1/4"N EPLL5/16-3/8"N EPLL3/8-1/4"N EPLL3/8-3/8"N EPLL3/8-1/2"N EPLL1/2-1/4"N EPLL1/2-3/8"N EPLL1/2-1/2"N

**Tube(Inch)-Thread(NPT):** EPOC5/32-1/8"N EPOC1/4-1/8"N EPOC1/4-1/4"N EPOC5/16-1/8"N EPOC5/16-1/8"N EPOC5/16-1/4"N EPOC5/16-3/8"N EPOC3/8-1/4"N EPOC3/8-3/8"N EPOC3/8-1/2"N EPOC1/2-1/4"N EPOC1/2-3/8"N EPOC1/2-1/2"N

**Tube(Inch)-Thread(NPT):** EPMF5/32-1/8"N EPMF3/16-1/8"N EPMF3/16-1/4"N EPMF1/4-1/8"N EPMF1/4-1/4"N EPMF5/16-1/8"N EPMF5/16-1/4"N EPMF5/16-3/8"N EPMF3/8-1/4"N EPMF3/8-3/8"N EPMF1/2-3/8"N EPMF1/2-1/2"N

One Touch-In Fitting General items

EPBF

Model [ D-T ]



**Tube(Metric)-Thread(PT):** EPBF04-M5 EPBF04-M6 EPBF04-01 EPBF04-02 EPBF06-M5 EPBF06-M6 EPBF06-01 EPBF06-02 EPBF06-03 EPBF06-04 EPBF08-01 EPBF08-02 EPBF08-03 EPBF08-04 EPBF10-01 EPBF10-02 EPBF10-03 EPBF10-04 EPBF12-02 EPBF12-03 EPBF12-04 EPBF14-03 EPBF14-04 EPBF16-03 EPBF16-04  
**Tube(Inch)-Thread(PT):** EPBF1/4-01 EPBF1/4-02 EPBF1/4-03 EPBF5/16-01 EPBF5/16-02 EPBF5/16-03 EPBF3/8-01 EPBF3/8-02 EPBF3/8-03 EPBF3/8-04 EPBF1/2-02 EPBF1/2-03 EPBF1/2-04

EPD

Model [ D-T ]

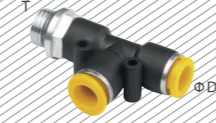

**Tube(Metric)-Thread(PT):** EPD04-M5 EPD04-M6/EPD04-01 EPD04-02 EPD06-M5 EPD06-M6 EPD06-01 EPD06-02 EPD06-03 EPD06-04 EPD08-01 EPD08-02 EPD08-03 EPD08-04 EPD10-01 EPD10-02 EPD10-03 EPD10-04 EPD12-02 EPD12-03 EPD12-04 EPD14-03 EPD14-04 EPD16-03 EPD16-04  
**Tube(Inch)-Thread(PT):** EPD1/4-01 EPD1/4-02 EPD1/4-03 EPD5/16-01 EPD5/16-02 EPD5/16-03 EPD3/8-01 EPD3/8-02 EPD3/8-03 EPD3/8-04 EPD1/2-02 EPD1/2-03 EPD1/2-04

EPHF

Model [ D-T ]



**Tube(Metric)-Thread(PT):** EPHF04-M5 EPHF04-M6 EPHF04-01 EPHF04-02 EPHF06-M5 EPHF06-M6 EPHF06-01 EPHF06-02 EPHF06-03 EPHF08-01 EPHF08-02 EPHF08-03 EPHF08-04 EPHF10-02 EPHF10-03 EPHF10-04 EPHF12-02 EPHF12-03 EPHF12-04  
**Tube(Inch)-Thread(PT):** EPHF1/4-M5 EPHF1/4-01 EPHF1/4-02 EPHF5/16-01 EPHF5/16-02 EPHF5/16-03/EPHF3/8-02 EPHF3/8-03

EPH

Model [ D-T ]



**Tube(Metric)-Thread(PT):** EPH04-M5 EPH04-M6 EPH04-01 EPH04-02 EPH06-M5 EPH06-M6 EPH06-01 EPH06-02 EPH06-03 EPH08-01 EPH08-02 EPH08-03 EPH08-04 EPH10-02 EPH10-03 EPH10-04 EPH12-02 EPH12-03 EPH12-04  
**Tube(Inch)-Thread(PT):** EPH1/4-M5 EPH1/4-01 EPH1/4-02 EPH5/16-01 EPH5/16-02 EPH5/16-03 EPH3/8-02 EPH3/8-03

**Tube(Inch)-Thread(NPT):** EPBF5/32-1/8"N EPBF5/32-1/4"N EPBF3/16-1/8"N EPBF3/16-1/4"N EPBF3/16-3/8"N EPBF1/4-1/8"N EPBF1/4-1/4"N EPBF1/4-3/8"N EPBF5/16-1/8"N EPBF5/16-1/4"N EPBF5/16-3/8"N EPBF3/8-1/8"N EPBF3/8-1/4"N EPBF3/8-3/8"N EPB3/8-1/2"N EPBF1/2-1/4"N EPBF1/2-3/8"N EPBF1/2-1/2"N

**Tube(Inch)-Thread(NPT):** EPD 1/4-1/4"N EPD 1/4-3/8"N EPD 5/16-1/8"N EPD 5/16-1/4"N EPD 5/16-3/8"N EPD 3/8-1/8"N EPD 3/8-1/4"N EPD 3/8-3/8"N EPD 3/8-1/2"N EPD 5/32-1/8"N EPD 5/32-1/4"N EPD 3/16-1/8"N EPD 3/16-1/4"N EPD 3/16-3/8"N EPD1/4-1/8"N EPD1/2-1/4"N EPD1/2-3/8"N EPD1/2-1/2"N

**Tube(Inch)-Thread(NPT):** EPHF5/32-1/8"N EPHF3/16-1/8"N EPHF3/16-1/4"N EPHF1/4-1/8"N EPHF1/4-1/4"N EPHF5/16-1/8"N EPHF5/16-1/4"N EPHF5/16-3/8"N EPHF3/8-1/4"N EPHF3/8-3/8"N EPHF1/2-3/8"N EPHF1/2-1/2"N

**Tube(Inch)-Thread(NPT):** EPH5/32-1/8"N EPH3/16-1/8"N EPH3/16-1/4"N EPH1/4-1/8"N EPH1/4-1/4"N EPH5/16-1/8"N EPH5/16-1/4"N EPH5/16-3/8"N EPH3/8-1/4"N EPH3/8-3/8"N EPH1/2-3/8"N EPH1/2-1/2"N

One Touch-In Fitting General items



EPIJ  
Model [ D ]

Tube(Metric): EPIJ04 EPIJ06 EPIJ08 EPIJ10 EPIJ12 EPIJ16  
Tube(Inch): EPIJ5/32 EPIJ3/16 EPIJ1/4 EPIJ5/16 EPIJ3/8 EPIJ1/2

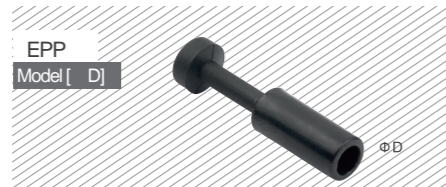

EPP  
Model [ D ]

Tube(Metric): EPP04 EPP06 EPP08 EPP10 EPP12 EPP16  
Tube(Inch): EPP5/32 EPP5/16



EPIG  
Model [ D1 - D2 ]

Tube(Metric): EPIG06-04 EPIG08-06 EPIG10-08 EPIG12-10

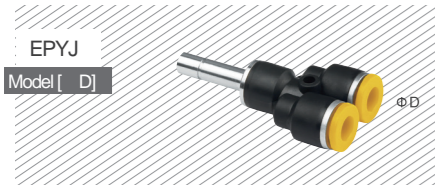

EPYJ  
Model [ D ]

Tube(Metric): EPYJ04 EPYJ06 EPYJ08 EPYJ10 EPYJ12  
Tube(Inch): EPYJ5/32 EPYJ3/16 EPYJ1/4 EPYJ5/16 EPYJ3/8 EPYJ1/2



EPLJ  
Model [ D ]

Tube(Metric): EPLJ04 EPLJ06 EPLJ08 EPLJ10 EPLJ12  
Tube(Inch): EPLJ5/32 EPLJ3/16 EPLJ1/4 EPLJ5/16 EPLJ3/8 EPLJ1/2



EPEJ  
Model [ D1 - D2 ]

Tube(Metric): EPEJ06-04 EPEJ08-06 EPEJ10-08 EPEJ12-10  
Tube(Inch): EPEJ1/4-5/32 EPEJ5/16-1/4 EPEJ3/8-5/16 EPEJ1/2-3/8

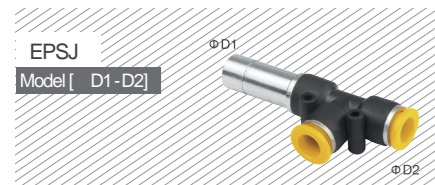

EPSJ  
Model [ D1 - D2 ]

Tube(Metric): EPSJ06-04 EPSJ08-06 EPSJ10-08 EPSJ12-10  
Tube(Inch): EPSJ1/4-5/32 EPSJ5/16-1/4 EPSJ3/8-5/16 EPSJ1/2-3/8

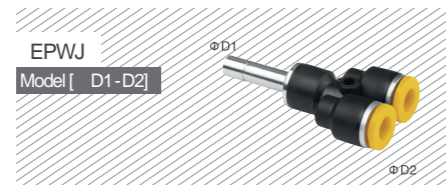

EPWJ  
Model [ D1 - D2 ]

Tube(Metric): EPWJ06-04 EPWJ08-06 EPWJ10-08 EPWJ12-10  
Tube(Inch): EPWJ1/4-5/32 EPWJ5/16-1/4 EPWJ3/8-5/16 EPWJ1/2-3/8

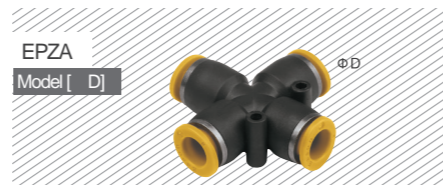

EPZA  
Model [ D ]

Tube(Metric): EPZA04 EPZA06 EPZA08 EPZA10 EPZA12  
Tube(Inch): EPZA5/32 EPZA3/16 EPZA1/4 EPZA5/16 EPZA3/8 EPZA1/2

One Touch-In Fitting General items



EPW  
Model [ D1 - D2 ]

Tube(Metric): EPW06-04 EPW08-06 EPW10-08 EPW12-10  
Tube(Inch): EPW3/16-5/32 EPW1/4-5/32 EPW1/4-3/16 EPW5/16-1/4 EPW3/8-5/16 EPW1/2-3/8

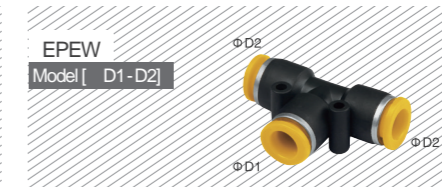

EPEW  
Model [ D1 - D2 ]

Tube(Metric): EPEW06-04 EPEW08-06 EPEW10-08 EPEW12-10 EPEW16-12  
Tube(Inch): EPEW1/4-5/32 EPEW5/16-1/4 EPEW3/8-5/16 EPEW1/2-3/8



EPK  
Model [ D ]

Tube(Metric): EPK04 EPK06 EPK08  
Tube(Inch): EPK5/32 EPK3/16 EPK1/4 EPK5/16



EPKG  
Model [ D1 - D2 ]

Tube(Metric): EPKG06-04 EPKG08-04 EPKG08-06 EPKG10-06 EPKG10-08  
Tube(Inch): EPKG3/16-5/32 EPKG1/4-5/32 EPKG5/16-5/32 EPKG3/16-3/16 EPKG5/16-1/4 EPKG3/8-1/4 EPKG3/8-5/16



EPKB  
Model [ D - T ]

Tube(Metric): EPKB04-01 EPKB04-02 EPKB06-01 EPKB06-02 EPKB06-03 EPKB08-01 EPKB08-02 EPKB08-03

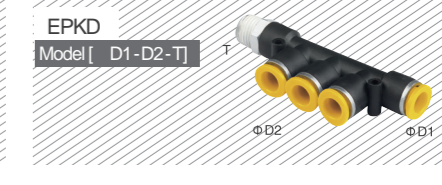

EPKD  
Model [ D1 - D2 - T ]

Tube(Metric): EPKD06-04-1 EPKD08-04-2 EPKD08-06-2 EPKD10-08-3  
Tube(Inch): EPKD3/16-5/32-N1 EPKD1/4-5/32-N1 EPKD5/16-5/32-N2 EPKD5/16-1/4-N2 EPKD3/8-5/16-N3



ESC-G  
Model [ D - T ]

Tube(Metric): ESC04-G01 ESC04-G02 ESC06-G01 ESC06-G02 ESC06-G03 ESC06-G04 ESC08-G01 ESC08-G02 ESC08-G03 ESC08-G04 ESC10-G01 ESC10-G02 ESC10-G03 ESC10-G04 ESC12-G02 ESC12-G03 ESC12-G04

## One Touch-in Fitting with O-Ring

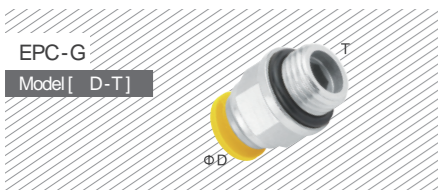

**Tube(Metric)-Thread(G):** EPC04-G01 EPC04-G02 EPC06-G01 EPC06-G02 EPC06-G03 EPC06-G04 EPC08-G01 EPC08-G02 EPC08-G03 EPC08-G04 EPC10-G01 EPC10-G02 EPC10-G03 EPC10-G04 EPC12-G02 EPC12-G03 EPC12-G04 EPC14-G03 EPC14-G04 EPC16-G03 EPC16-G04

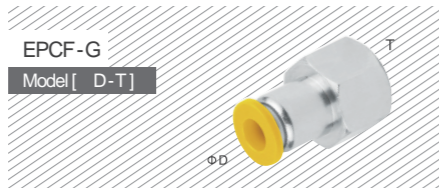

**Tube(Metric)-Thread(G):** EPCF04-G01 EPCF04-G02 EPCF06-G01 EPCF06-G02 EPCF06-G03 EPCF08-G01 EPCF08-G02 EPCF08-G03 EPCF08-G04 EPCF10-G01 EPCF10-G02 EPCF10-G03 EPCF10-G04 EPCF12-G02 EPCF12-G03 EPCF12-G04 EPCF14-G03 EPCF14-G04 EPCF16-G03 EPCF16-G04



**Tube(Metric)-Thread(G):** EPL04-G01 EPL04-G02 EPL06-G01 EPL06-G02 EPL06-G03 EPL06-G04 EPL08-G01 EPL08-G02 EPL08-G03 EPL08-G04 EPL10-G01 EPL10-G02 EPL10-G03 EPL10-G04 EPL12-G02 EPL12-G03 EPL12-G04 EPL14-G03 EPL14-G04 EPL16-G03 EPL16-G04



**Tube(Metric)-Thread(G):** EPB04-G01 EPB04-G02 EPB06-G01 EPB06-G02 EPB06-G03 EPB06-G04 EPB08-G01 EPB08-G02 EPB08-G03 EPB08-G04 EPB10-G01 EPB10-G02 EPB10-G03 EPB10-G04 EPB12-G03 EPB12-G04 EPB14-G03 EPB14-G04 EPB16-G03 EPB16-G04

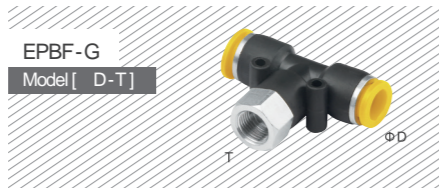

**Tube(Metric)-Thread(G):** EPBF04-G01 EPBF04-G02 EPBF06-G01 EPBF06-G02 EPBF06-G03 EPBF06-G04 EPBF08-G01 EPBF08-G02 EPBF08-G03 EPBF08-G04 EPBF10-G01 EPBF10-G02 EPBF10-G03 EPBF10-G04 EPBF12-G02 EPBF12-G03 EPBF12-G04 EPBF14-G03 EPBF14-G04 EPBF16-G03 EPBF16-G04

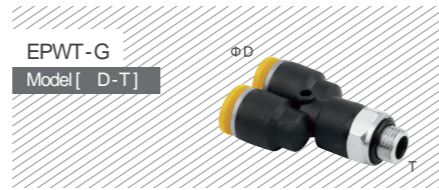

**Tube(Metric)-Thread(G):** EPWT04-G01 EPWT04-G02 EPWT06-G01 EPWT06-G02 EPWT06-G03 EPWT06-G04 EPWT08-G01 EPWT08-G02 EPWT08-G03 EPWT08-G04 EPWT10-G01 EPWT10-G02 EPWT10-G03 EPWT10-G04 EPWT12-G02 EPWT12-G03 EPWT12-G04

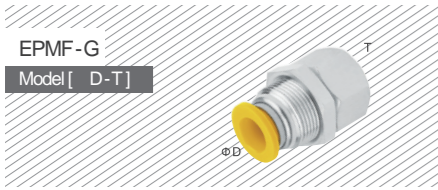

**Tube(Metric)-Thread(G):** EPMF04-G01 EPMF04-G02 EPMF06-G01 EPMF06-G02 EPMF06-G03 EPMF06-G04 EPMF08-G01 EPMF08-G02 EPMF08-G03 EPMF08-G04 EPMF10-G01 EPMF10-G02 EPMF10-G03 EPMF10-G04 EPMF12-G02 EPMF12-G03 EPMF12-G04 EPMF14-G03 EPMF14-G04 EPMF16-G03 EPMF16-G04

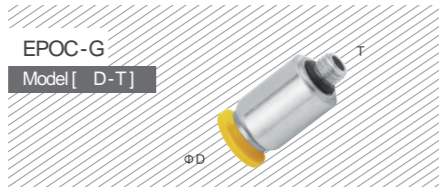

**Tube(Metric)-Thread(G):** EPOC04-G01 EPOC04-G02 EPOC06-G01 EPOC06-G02 EPOC06-G03 EPOC06-G04 EPOC08-G01 EPOC08-G02 EPOC08-G03 EPOC08-G04 EPOC10-G01 EPOC10-G02 EPOC10-G03 EPOC10-G04 EPOC12-G02 EPOC12-G03 EPOC12-G04 EPOC14-G03 EPOC14-G04 EPOC16-G03 EPOC16-G04



**Tube(Metric)-Thread(G):** EPLF04-G01 EPLF04-G02 EPLF06-G01 EPLF06-G02 EPLF06-G03 EPLF08-G01 EPLF08-G02 EPLF08-G03 EPLF08-G04 EPLF10-G01 EPLF10-G02 EPLF10-G03 EPLF10-G04 EPLF12-G02 EPLF12-G03 EPLF12-G04 EPLF14-G03 EPLF14-G04 EPLF16-G03 EPLF16-G04

## One Touch-in Fitting with O-ring / Hand Valve

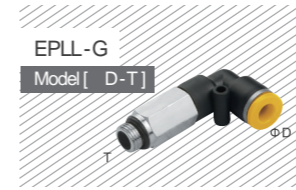

**Tube(Metric)-Thread(G):** EPLL04-G01 EPLL04-G02 EPLL06-G01 EPLL06-G02 EPLL06-G03 EPLL06-G04 EPLL08-G01 EPLL08-G02 EPLL08-G03 EPLL08-G04 EPLL10-G01 EPLL10-G02 EPLL10-G03 EPLL10-G04 EPLL12-G02 EPLL12-G03 EPLL12-G04 EPLL14-G03 EPLL14-G04 EPLL16-G03 EPLL16-G04

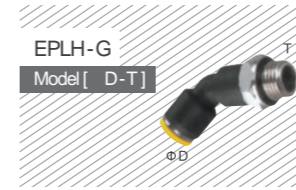

**Tube(Metric)-Thread(G):** EPLH04-G01 EPLH04-G02 EPLH06-G01 EPLH06-G02 EPLH06-G03 EPLH06-G04 EPLH08-G01 EPLH08-G02 EPLH08-G03 EPLH08-G04 EPLH10-G01 EPLH10-G02 EPLH10-G03 EPLH10-G04 EPLH12-G02 EPLH12-G03 EPLH12-G04 EPLH14-G03 EPLH14-G04 EPLH16-G03 EPLH16-G04



**Tube(Metric)-Thread(G):** EPD04-G01 EPD04-G02 EPD06-G01 EPD06-G02 EPD06-G03 EPD06-G04 EPD08-G01 EPD08-G02 EPD08-G03 EPD08-G04 EPD10-G01 EPD10-G02 EPD10-G03 EPD10-G04 EPD12-G02 EPD12-G03 EPD12-G04 EPD14-G03 EPD14-G04 EPD16-G03 EPD16-G04

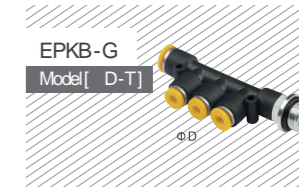

**Tube(Metric)-Thread(G):** EPKB06-G01 EPKB06-G02 EPKB06-G03 EPKB08-G01 EPKB08-G02 EPKB08-G03



**Tube(Metric)-Thread(G):** EPKD06-04-G01 EPKD08-04-G02 EPKD08-06-G02 EPKD10-08-G03



**Tube(Metric)-Thread(G):** EPHF04-G01 EPHF06-G01 EPHF06-G02 EPHF08-G01 EPHF08-G02 EPHF08-G03 EPHF10-G02 EPHF10-G03 EPHF12-G03 EPHF12-G04

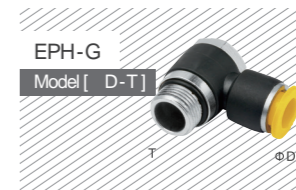

**Tube(Metric)-Thread(G):** EPH04-G01 EPH06-G01/EPH06-G02 EPH08-G01 EPH08-G02 EPH08-G03 EPH10-G02 EPH10-G03 EPH12-G03 EPH12-G04



**Thread(PT):** EHVSS01-01 EHVSS02-01 EHVSS02-02 EHVSS03-02 EHVSS03-03 EHVSS04-03 EHVSS04-04

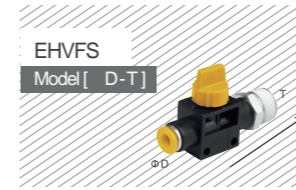

**Tube(Metric)-Thread(PT):** EHVFS06-01 EHVFS06-02 EHVFS06-03 EHVFS08-01 EHVFS08-02 EHVFS08-03 EHVFS10-02 EHVFS10-03 EHVFS10-04 EHVFS12-02 EHVFS12-03 EHVFS12-04

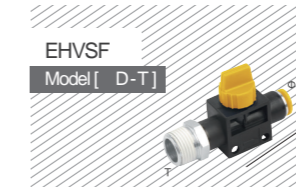

**Tube(Metric)-Thread(PT):** EHVSF01-06 EHVSF02-06 EHVSF03-06 EHVSF01-08 EHVSF02-08 EHVSF03-08 EHVSF02-10 EHVSF03-10 EHVSF04-10 EHVSF02-12 EHVSF03-12 EHVSF04-12

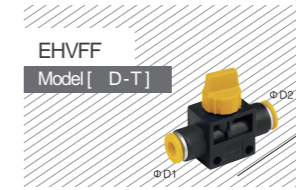

**Tube(Metric):** EHVFF06-06 EHVFF08-06 EHVFF08-08 EHVFF10-08 EHVFF10-10 EHVFF12-10 EHVFF12-12

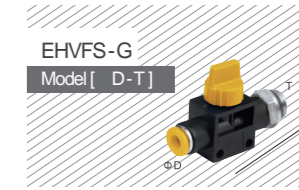

**Tube(Metric)-Thread(PT):** EHVFS06-G01 EHVFS06-G02 EHVFS06-G03 EHVFS08-G01 EHVFS08-G02 EHVFS08-G03 EHVFS10-G02 EHVFS10-G03 EHVFS10-G04 EHVFS12-G02 EHVFS12-G03 EHVFS12-G04

## Hand Valve / Mini Fitting

### Hand valve

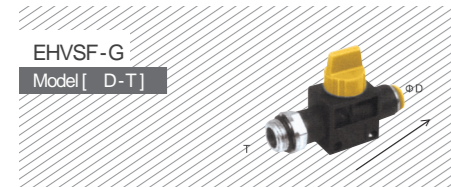

**Tube(Metric) - Thread(PT):**  
EHVFS G01-06 EHVFS G02-06 EHVFS G03-06 EHVFS G01-08 EHVFSG02-08 EHVFS G03-08 EHVFS G02-10 EHVFS G03-10 EHVFS G04-10 EHVFS G02-12 EHVFS G03-12 EHVFS G04-12

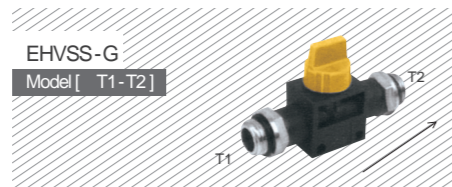

**Thread(PT):**  
EHVSS01-G02 EHVSS02-G01 EHVSS02-G02 EHVSS03-G02 EHVSS03-G03 EHVSS04-G03 EHVSS04-G04

### Mini fitting

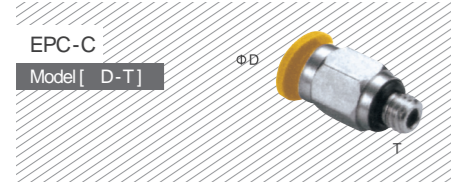

**Tube(Metric):**  
EPC03-M3C EPC03-M5C EPC03-M6C  
EPC04-M3C EPC04-M5C EPC04-M6C EPC04-01C  
EPC06-M5C EPC06-M6C EPC06-01C

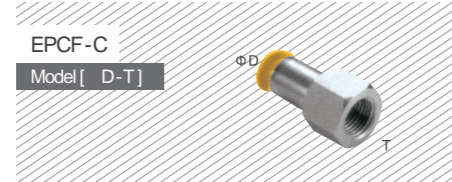

**Tube(Metric):**  
EPCF03-M3C EPCF03-M5C EPCF03-M6C  
EPCF04-M3C EPCF04-M5C EPCF04-M6C EPCF04-01C  
EPCF06-M5C EPCF06-M6C EPCF06-01C

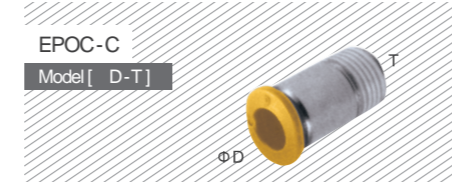

**Tube(Metric):**  
EPOC03-M3C EPOC03-M5C EPOC03-M6C  
EPOC04-M3C EPOC04-M5C EPOC04-M6C EPOC04-01C  
EPOC06-M5C EPOC06-M6C EPOC06-01C



**Tube(Metric):**  
EPD03-M3C EPD03-M5C EPD03-M6C  
EPD04-M3C EPD04-M5C EPD04-M6C EPD04-01C  
EPD06-M5C EPD06-M6C EPD06-01C



**Tube(Metric):**  
EPD03-M3C EPD03-M5C EPD03-M6C  
EPD04-M3C EPD04-M5C EPD04-M6C EPD04-01C  
EPD06-M5C EPD06-M6C EPD06-01C

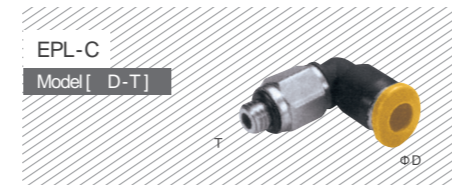

**Tube(Metric):**  
EPL03-M3C EPL03-M5C EPL03-M6C  
EPL04-M3C EPL04-M5C EPL04-M6C EPL04-01C  
EPL06-M5C EPL06-M6C EPL06-01C

## Mini Fitting



**Tube(Metric):**  
EPLL03-M3C EPLL03-M5C EPLL03-M6C  
EPLL04-M3C EPLL04-M5C EPLL04-M6C  
EPLL04-01C EPLL06-M5C EPLL06-M6C  
EPLL06-01C

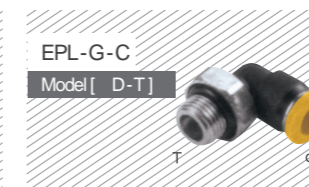

**Tube(Metric):**  
EPL04-G01C EPL04-G02C

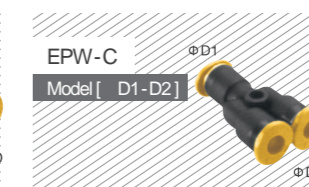

**Tube(Metric):**  
EPW04-03C EPW06-03C EPW06-04C



**Tube(Metric):**  
EPY03C EPY04C EPY06C



**Tube(Metric):**  
EPE03C EPE04C EPE06C

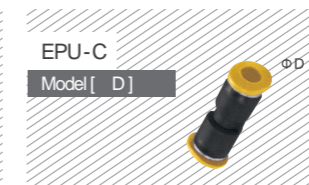

**Tube(Metric):**  
EPU03C EPU04C EPU06C

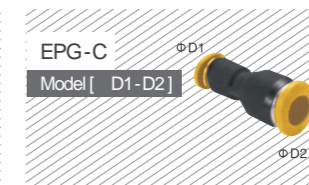

**Tube(Metric):**  
EPG04-03C EPG06-03C EPG06-04C

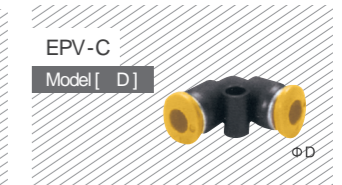

**Tube(Metric):**  
EPV03C EPV04C EPV06C



**Tube(Metric):**  
EMJKH-3-M5

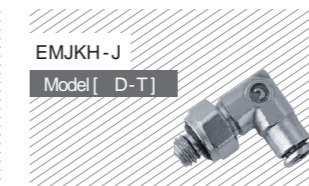

**Tube(Metric):**  
EMJKH-J-3-M3 EMJKH-J-3-M5



**Tube(Metric):**  
EMJKH-JJ-3-M3 EMJKH-JJ-3-M5

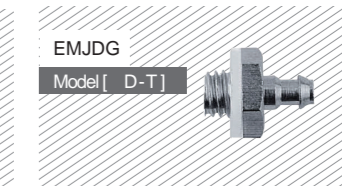

**Tube(Metric):**  
EMJDG-3-M3 EMJDG-4-M5



## Mini fitting

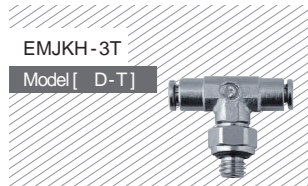

Tube(Metric):  
EMJKH-3T-3-M3 EMJKH-3T-3-M5



Tube(Metric):  
EMJKH-3Y-3-M3 EMJKH-3Y-3-M5

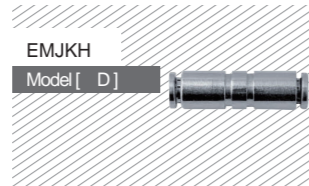

Tube(Metric):  
EMJKH-3

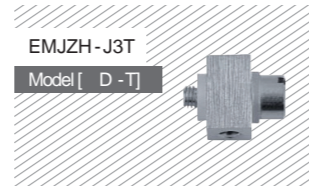

Tube(Metric):  
EMJZH-J3T-3-M3 EMJZH-J3T-4-M5

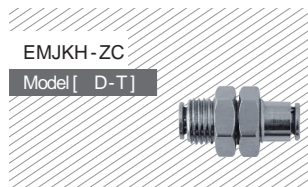

Tube(Metric):  
EMJKH-ZC-3



Tube(Metric):  
EMJKH-J-3

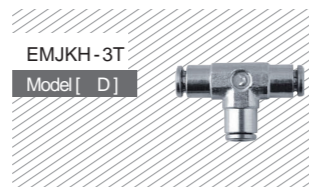

Tube(Metric):  
EMJKH-3T-3

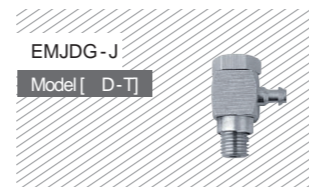

Tube(Metric):  
EMJDG-J-3-M3 EMJDG-J-3-M5

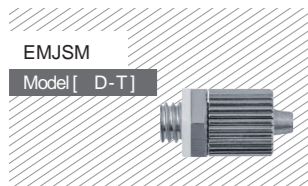

Tube(Metric):  
EMJSM-3-M3 EMJSM-4-M5

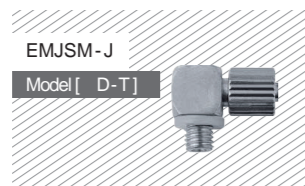

Tube(Metric):  
EMJSM-J-3-M3 EMJSM-J-4-M5

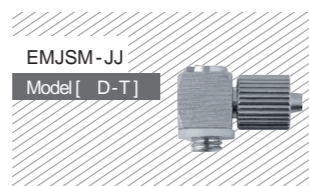

Tube(Metric):  
EMJSM-JJ-3-M3 EMJSM-JJ-4-M5

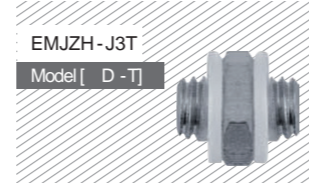

Tube(Metric):  
EMJZH-J3T-3-M3 EMJZH-J3T-4-M5

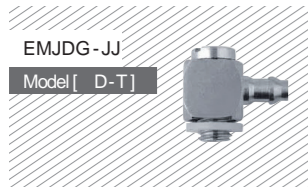

Tube(Metric):  
EMJDG-JJ-3-M3 EMJDG-JJ-4-M5

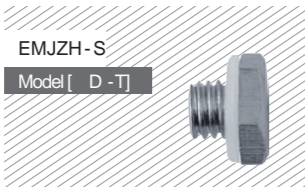

Tube(Metric):  
EMJZH-S-3-M3 EMJZH-S-4-M5

## E-KJ Series Mini fitting



Tube(Metric)-Thread(PT):  
E-KJS 03-M3 E-KJS 03-M5 E-KJS 23-M3 E-KJS 23-M5  
E-KJS 04-M3 E-KJS 04-M5 E-KJS 04-M6 E-KJS 04-01S  
E-KJS 06-M5 E-KJS 06-M6 E-KJS 06-01S



Tube(Metric):  
E-KJH 03-00 E-KJH 23-00 E-KJH 04-00 E-KJH 06-00  
E-KJH 03-04 E-KJH 23-04 E-KJH 04-06



Tube(Metric)-Thread(PT):  
E-KJY 03-M3 E-KJY 03-M5 E-KJY 03-M6 E-KJY 03-01S  
E-KJY 23-M3 E-KJY 23-M5 E-KJY 23-M6 E-KJY 23-01S  
E-KJY 04-M3 E-KJY 04-M5 E-KJY 04-M6 E-KJY 04-01S  
E-KJY 06-M5 E-KJY 06-M6 E-KJY 06-01S



Tube(Metric)-Thread(PT):  
E-KJF03-M3 E-KJF03-M5 E-KJF23-M3 E-KJF23-M5  
E-KJF04-M3 E-KJF04-M5 E-KJF06-M5



Tube(Metric):  
E-KJU 03-00 E-KJU 23-00 E-KJU 04-00 E-KJU 06-00  
E-KJU 03-04 E-KJU 23-04 E-KJU 04-06



Tube(Metric)-Thread(PT):  
E-KJT 03-M3 E-KJT 03-M5 E-KJT 03-M6 E-KJT 03-01S  
E-KJT 23-M3 E-KJT 23-M5 E-KJT 23-M6 E-KJT 23-01S  
E-KJT 04-M3 E-KJT 04-M5 E-KJT 04-M6 E-KJT 04-01S  
E-KJT 06-M5 E-KJT 06-M6 E-KJT 06-01S

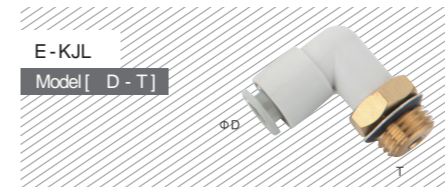

Tube(Metric)-Thread(PT):  
E-KJL 03-M3 E-KJL 03-M5 E-KJL 03-M6 E-KJL 03-01S  
E-KJL 23-M3 E-KJL 23-M5 E-KJL 23-M6 E-KJL 23-01S  
E-KJL 04-M3 E-KJL 04-M5 E-KJL 04-M6 E-KJL 04-01S  
E-KJL 06-M5 E-KJL 06-M6 E-KJL 06-01S



Tube(Metric):  
E-KJT 03-00 E-KJT 23-00 E-KJT 04-00 E-KJT 06-00

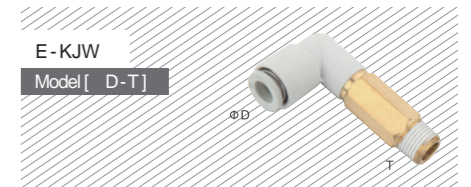

Tube(Metric)-Thread(PT):  
E-KJW 03-M3 E-KJW 03-M5 E-KJW 03-M6 E-KJW 03-01S  
E-KJW 23-M3 E-KJW 23-M5 E-KJW 23-M6 E-KJW 23-01S  
E-KJW 04-M3 E-KJW 04-M5 E-KJW 04-M6 E-KJW 04-01S  
E-KJW 06-M5 E-KJW 06-M6 E-KJW 06-01S

Tube(Metric):  
E-KJL 03-00 E-KJL 23-00 E-KJL 04-00 E-KJL 06-00

## E-KQ Series Mini fitting

E-KQ2H  
Model [ D - T ]

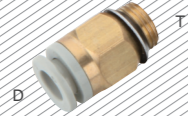

Model:  
E-KQ2H 04-01S E-KQ2H 04-02S E-KQ2H 06-01S  
E-KQ2H 06-02S E-KQ2H 06-03S E-KQ2H 06-04S  
E-KQ2H 08-01S E-KQ2H 08-02S E-KQ2H 08-03S  
E-KQ2H 08-04S E-KQ2H 10-01S E-KQ2H 10-02S  
E-KQ2H 10-03S E-KQ2H 10-04S E-KQ2H 12-01S  
E-KQ2H 12-02S E-KQ2H 12-03S E-KQ2H 12-04S  
E-KQ2H 16-02S E-KQ2H 16-03S E-KQ2H 16-04S

E-KQ2L  
Model [ D - T ]

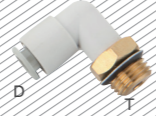

Model:  
E-KQ2L 04-01S E-KQ2L 04-02S E-KQ2L 06-01S  
E-KQ2L 06-02S E-KQ2L 06-03S E-KQ2L 06-04S  
E-KQ2L 08-01S E-KQ2L 08-02S E-KQ2L 08-03S  
E-KQ2L 08-04S E-KQ2L 10-01S E-KQ2L 10-02S  
E-KQ2L 10-03S E-KQ2L 10-04S E-KQ2L 12-01S  
E-KQ2L 12-02S E-KQ2L 12-03S E-KQ2L 12-04S  
E-KQ2L 16-02S E-KQ2L 16-03S E-KQ2L 16-04S

E-KQ2S  
Model [ D - T ]

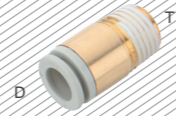

Model:  
E-KQ2S 04-01S E-KQ2S 04-02S E-KQ2S 06-01S  
E-KQ2S 06-02S E-KQ2S 08-01S E-KQ2S 08-02S  
E-KQ2S 08-03S E-KQ2S 10-01S E-KQ2S 10-02S  
E-KQ2S 10-03S E-KQ2S 10-04S E-KQ2S 12-02S  
E-KQ2S 12-03S E-KQ2S 12-04S E-KQ2S 16-03S  
E-KQ2S 16-04S

## E-KQ Series fitting

E-KQ2E  
Model [ D - T ]

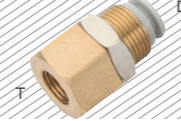

Model:  
E-KQ2E 04-01 E-KQ2E 04-02 E-KQ2E 06-01 E-KQ2E 06-02  
E-KQ2E 06-03 E-KQ2E 08-01 E-KQ2E 08-02 E-KQ2E 08-03  
E-KQ2E 10-02 E-KQ2E 10-03 E-KQ2E 12-03 E-KQ2E 12-04  
E-KQ2E 16-03 E-KQ2E 16-04

E-KQ2LU  
Model [ D - T ]

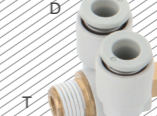

Model:  
E-KQ2LU 04-M5 E-KQ2LU 04-M6 E-KQ2LU 04-01S  
E-KQ2LU 04-02S/ E-KQ2LU 06-M5 E-KQ2LU 06-M6  
E-KQ2LU 06-01S E-KQ2LU 06-02S E-KQ2LU 06-03S  
E-KQ2LU 08-01S E-KQ2LU 08-02S E-KQ2LU 08-03S  
E-KQ2LU 10-02S E-KQ2LU 10-03S E-KQ2LU 10-04S  
E-KQ2LU 12-02S E-KQ2LU 12-03S E-KQ2LU 12-04S

E-KQ2V  
Model [ D - T ]



Model:  
E-KQ2V 04-M5 E-KQ2V 04-01S E-KQ2V 06-M5  
E-KQ2V 06-01S E-KQ2V 06-02S E-KQ2V 08-01S  
E-KQ2V 08-02S E-KQ2V 08-03S E-KQ2V 10-02S  
E-KQ2V 10-03S E-KQ2V 12-03S E-KQ2V 12-04S

E-KQ2F  
Model [ D - T ]



Model:  
E-KQ2F04-01 E-KQ2F04-02 E-KQ2F06-01 E-KQ2F06-02  
E-KQ2F06-03 E-KQ2F08-01 E-KQ2F08-02 E-KQ2F08-03  
E-KQ2F10-02 E-KQ2F10-03 E-KQ2F12-02 E-KQ2F12-03  
E-KQ2F12-04 E-KQ2F16-03 E-KQ2F16-04

E-KQ2T  
Model [ D - T ]



Model:  
E-KQ2T 04-01S E-KQ2T 04-02S E-KQ2T 06-01S  
E-KQ2T 06-02S E-KQ2T 06-03S E-KQ2T 06-04S  
E-KQ2T 08-01S E-KQ2T 08-02S E-KQ2T 08-03S  
E-KQ2T 08-04S E-KQ2T 10-01S E-KQ2T 10-02S  
E-KQ2T 10-03S E-KQ2T 10-04S E-KQ2T 12-01S  
E-KQ2T 12-02S E-KQ2T 12-03S E-KQ2T 12-04S  
E-KQ2T 16-02S E-KQ2T 16-03S E-KQ2T 16-04S

E-KQ2Y  
Model [ D - T ]



Model:  
E-KQ2Y 04-01S E-KQ2Y 04-02S E-KQ2Y 06-01S  
E-KQ2Y 06-02S E-KQ2Y 06-03S E-KQ2Y 08-01S  
E-KQ2Y 08-02S E-KQ2Y 08-03S E-KQ2Y 10-01S  
E-KQ2Y 10-02S E-KQ2Y 10-03S E-KQ2Y 10-04S  
E-KQ2Y 12-02S E-KQ2Y 12-03S E-KQ2Y 12-04S

E-KQ2VF  
Model [ D - T ]



Model:  
E-KQ2VF 04-M5 E-KQ2VF 04-01S E-KQ2VF 06-M5  
E-KQ2VF 06-01S E-KQ2VF 06-02S E-KQ2VF 08-01S  
E-KQ2VF 08-02S E-KQ2VF 08-03S E-KQ2VF 10-02S  
E-KQ2VF 10-03S E-KQ2VF 12-03S E-KQ2VF 12-04S

E-KQ2VS  
Model [ D - T ]



Model:  
E-KQ2VS 04-M5 E-KQ2VS 04-01S E-KQ2VS 06-M5  
E-KQ2VS 06-01S E-KQ2VS 06-02S E-KQ2VS 08-01S  
E-KQ2VS 08-02S E-KQ2VS 08-03S E-KQ2VS 10-02S  
E-KQ2VS 10-03S E-KQ2VS 12-03S E-KQ2VS 12-04S

E-KQ2ZF  
Model [ D - T ]

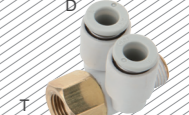

Model:  
E-KQ2ZF 04-M5 E-KQ2ZF 04-01S E-KQ2ZF 06-M5  
E-KQ2ZF 06-01S E-KQ2ZF 06-02S E-KQ2ZF 08-01S  
E-KQ2ZF 08-02S E-KQ2ZF 10-02S E-KQ2ZF 10-03S  
E-KQ2ZF 12-03S E-KQ2ZF 12-04S

E-KQ2U  
Model [ D - T ]



Model:  
E-KQ2U 04-01S E-KQ2U 04-02S E-KQ2U 06-01S  
E-KQ2U 06-02S E-KQ2U 06-03S E-KQ2U 08-01S  
E-KQ2U 08-02S E-KQ2U 08-03S E-KQ2U 10-01S  
E-KQ2U 10-02S E-KQ2U 10-03S E-KQ2U 10-04S  
E-KQ2U 12-02S E-KQ2U 12-03S E-KQ2U 12-04S

E-KQ2W  
Model [ D - T ]



Model:  
E-KQ2W 04-01S E-KQ2W 04-02S E-KQ2W 06-01S  
E-KQ2W 06-02S E-KQ2W 06-03S E-KQ2W 08-01S  
E-KQ2W 08-02S E-KQ2W 08-03S E-KQ2W 10-02S  
E-KQ2W 10-03S E-KQ2W 10-04S E-KQ2W 12-02S  
E-KQ2W 12-03S E-KQ2W 12-04S

E-KQ2LF  
Model [ D - T ]



Model:  
E-KQ2LF 04-M5 E-KQ2LF 04-M6 E-KQ2LF 04-01  
E-KQ2LF 04-02 E-KQ2LF 06-M5 E-KQ2LF 06-M6  
E-KQ2LF 06-01 E-KQ2LF 06-02 E-KQ2LF 06-03  
E-KQ2LF 08-01 E-KQ2LF 08-02 E-KQ2LF 08-03  
E-KQ2LF 10-02 E-KQ2LF 10-03 E-KQ2LF 10-04  
E-KQ2LF 12-02 E-KQ2LF 12-03 E-KQ2LF 12-04

E-KQ2ZD  
Model [ D - T ]



Model:  
E-KQ2ZD 04-01S E-KQ2ZD 04-02S E-KQ2ZD 04-03S  
E-KQ2ZD 06-01S E-KQ2ZD 06-02S E-KQ2ZD 06-03S  
E-KQ2ZD 08-01S E-KQ2ZD 08-02S E-KQ2ZD 08-03S  
E-KQ2ZD 08-04S E-KQ2ZD 10-02S E-KQ2ZD 10-03S  
E-KQ2ZD 10-04S E-KQ2ZD 12-02S E-KQ2ZD 12-03S  
E-KQ2ZD 12-04S

E-KQ2ZT  
Model [ D - T ]



Model:  
E-KQ2ZT 04-01S E-KQ2ZT 04-02S E-KQ2ZT 04-03S  
E-KQ2ZT 06-01S E-KQ2ZT 06-02S E-KQ2ZT 06-03S  
E-KQ2ZT 08-01S E-KQ2ZT 08-02S E-KQ2ZT 08-03S  
E-KQ2ZT 08-04S E-KQ2ZT 10-02S E-KQ2ZT 10-03S  
E-KQ2ZT 10-04S E-KQ2ZT 12-02S E-KQ2ZT 12-03S  
E-KQ2ZT 12-04S

E-KQ2T  
Model [ D1 - D2 ]



Model:  
E-KQ2T 04-00 E-KQ2T 06-00 E-KQ2T 08-00  
E-KQ2T 10-00 E-KQ2T 12-00 E-KQ2T 16-00  
E-KQ2T 04-06 E-KQ2T 06-08 E-KQ2T 08-10  
E-KQ2T 10-12 E-KQ2T 12-16 E-KQ2T 06-04  
E-KQ2T 08-06 E-KQ2T 10-08 E-KQ2T 12-10  
E-KQ2T 16-12

## E-KQ Series Fitting

E-KQ2H

Model [ D1 - D2 ]



Model:

E-KQ2H 04-00 E-KQ2H 06-00 E-KQ2H 08-00  
E-KQ2H 10-00 E-KQ2H 12-00 E-KQ2H 16-00  
E-KQ2H 04-06 E-KQ2H 06-08 E-KQ2H 08-10  
E-KQ2H 10-12 E-KQ2H 12-16

E-KQ2L

Model [ D1 - D2 ]



Model:

E-KQ2L 04-00 E-KQ2L 06-00 E-KQ2L 08-00  
E-KQ2L 10-00 E-KQ2L 12-00 E-KQ2L 16-00  
E-KQ2L 04-06 E-KQ2L 06-08 E-KQ2L 08-10  
E-KQ2L 10-12 E-KQ2L 12-16

E-KQ2U

Model [ D1 - D2 ]



Model:

E-KQ2U 04-00 E-KQ2U 06-00 E-KQ2U 08-00  
E-KQ2U 10-00 E-KQ2U 12-00 E-KQ2U 16-00  
E-KQ2U 04-06 E-KQ2U 06-08 E-KQ2U 08-10  
E-KQ2U 10-12 E-KQ2U 12-16 E-KQ2U 06-04  
E-KQ2U 08-06 E-KQ2U 10-08 E-KQ2U 12-10  
E-KQ2U 16-12

E-KQ2LE

Model [ D-T ]

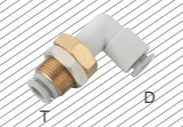

Model:

E-KQ2LE 04-00 E-KQ2LE 06-00  
E-KQ2LE 08-00 E-KQ2LE 10-00  
E-KQ2LE 12-00

E-KQ2U

Model [ D1 - D2 ]

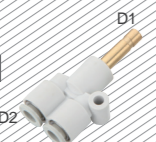

Model:

E-KQ2U 04-99 E-KQ2U 06-99 E-KQ2U 08-99  
E-KQ2U 10-99 E-KQ2U 12-99 E-KQ2U 16-99

E-KQ2X

Model [ D1 - D2 ]

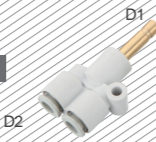

Model:

E-KQ2X 04-06 E-KQ2X 06-08 E-KQ2X 08-10  
E-KQ2X 10-12

E-KQ2UW

Model [ D1 - D2 ]

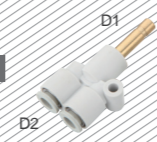

Model:

E-KQ2UW 04-99 E-KQ2UW 06-99  
E-KQ2UW 08-99 E-KQ2UW 10-99  
E-KQ2UW 12-99 E-KQ2UW 16-99

E-KQ2UD

Model [ D1 - D2 ]



Model:

E-KQ2UD 04-06 E-KQ2UD 06-08

E-KQ2L

Model [ D1 - D2 ]

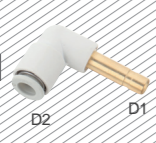

Model:

E-KQ2L 04-99 E-KQ2L 06-99 E-KQ2L 08-99  
E-KQ2L 10-99 E-KQ2L 12-99 E-KQ2L 16-99

E-KQ2W

Model [ D1 - D2 ]

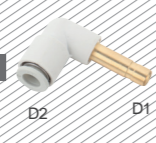

Model:

E-KQ2W 04-99 E-KQ2W 06-99  
E-KQ2W 08-99 E-KQ2W 10-99  
E-KQ2W 12-99 E-KQ2W 16-99

E-KQ2L

Model [ D1 - D2 ]

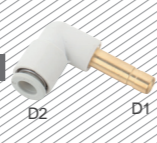

Model:

E-KQ2L 04-06 E-KQ2L 04-08 E-KQ2L 06-08  
E-KQ2L 06-10 E-KQ2L 08-10 E-KQ2L 08-12  
E-KQ2L 10-12 E-KQ2L 12-16

E-KQ2E

Model [ D ]

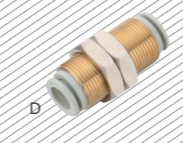

Model:

E-KQ2E 04-00 E-KQ2E 06-00  
E-KQ2E 08-00 E-KQ2E 10-00  
E-KQ2E 12-00 E-KQ2E 16-00

E-KQ2P

Model [ D ]



Model:

E-KQ2P 04 E-KQ2P 06 E-KQ2P 08  
E-KQ2P 10 E-KQ2P 12

E-KQ2N

Model [ D1 - D2 ]



Model:

E-KQ2N 04-06 E-KQ2N 06-08 E-KQ2N 08-10  
E-KQ2N 10-12 E-KQ2N 12-16

E-KQ2R

Model [ D1 - D2 ]



Model:

E-KQ2R 04-06 E-KQ2R 04-08 E-KQ2R 04-10  
E-KQ2R 06-04 E-KQ2R 06-08 E-KQ2R 06-10  
E-KQ2R 08-10 E-KQ2R 08-12 E-KQ2R 10-12

E-KQ2TW

Model [ D ]



Model:

E-KQ2TW 04-00 E-KQ2TW 06-00  
E-KQ2TW 08-00 E-KQ2TW 10-00  
E-KQ2TW 12-00

## E-KQ Series Fitting

E-KQ2C

Model [ D ]



Model:

E-KQ2C 04-00 E-KQ2C 06-00  
E-KQ2C 08-00 E-KQ2C 10-00  
E-KQ2C 12-00

E-KQ2LU

Model [ D ]



Model:

E-KQ2LU 04-00 E-KQ2LU 06-00  
E-KQ2LU 08-00 E-KQ2LU 10-00  
E-KQ2LU 12-00

## E-AS Series Flow Control Valve

E-AS-F

Model [ D-T ]



Model:

E-AS1201F M3-23 E-AS1201F M3-04 E-AS1201F M5-23  
E-AS1201F M5-04 E-AS2201F 01-04S E-AS2201F 01-06S  
E-AS2201F 01-08S E-AS2201F 01-10S E-AS2201F 02-04S  
E-AS2201F 02-06S E-AS2201F 02-08S E-AS2201F 02-10S  
E-AS2201F 03-06S E-AS3201F 03-08S E-AS3201F 03-10S  
E-AS3201F 03-12S E-AS4201F 04-10S E-AS4201F 04-12S

E-AS-F

Model [ D-T ]



Model:

E-AS1301F M3-23 E-AS1301F M3-04 E-AS1301F M5-23  
E-AS1301F M5-04 E-AS2301F 01-04S E-AS2301F 01-06S  
E-AS2301F 01-08S E-AS2301F 01-10S E-AS2301F 02-04S  
E-AS2301F 02-06S E-AS3301F 02-08S E-AS2301F 02-10S  
E-AS3301F 03-06S E-AS3301F 03-08S  
E-AS3301F 03-10S E-AS3301F 03-12S E-AS4301F 04-10S  
E-AS4301F 04-12S

E-AS-F

Model [ D ]



Model:

E-AS1001F-23 E-AS1001F-04 E-AS1001F-06  
E-AS2001F-04 E-AS2001F-06 E-AS2051F-06  
E-AS2051F-08 E-AS3001F-06 E-AS3001F-08  
E-AS3001F-10 E-AS3001F-12 E-AS4001F-10  
E-AS4001F-12

## E-AQ Series Quick Exhaust Valve

E-AQ

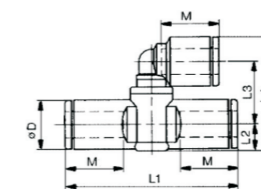

Model	L1	L2	L3	L4	D	M
E-AQ240F-04-04	39.5	5.4	13.8	23.4	9.6	12.8
E-AQ240F-06-06	41	6.3	14.9	26.8	11.4	13.6
E-AQ340F-06-06	45	6.5	19.5	31.9	11.4	13.6

E-AQ

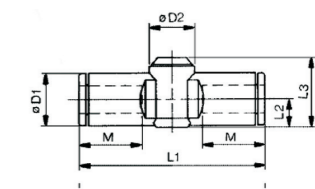

Model	L1	L2	L3	D1	D2	M
E-AQ240F-04-00	39.5	5.4	14.5	9.6	9.9	12.8
E-AQ240F-06-00	41	6.3	15.5	11.4	11.9	13.6
E-AQ340F-06-00	45	6.5	19.5	11.4	11.9	13.6

## Brass One Touch-In Fitting

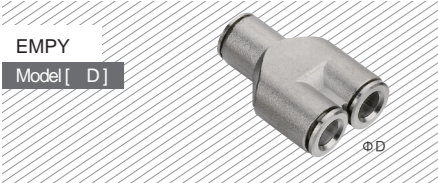

EMPY  
Model [ D ]

Tube(Metric):  
EMPY 4 EMPY 6 EMPY 8 EMPY 10 EMPY 12

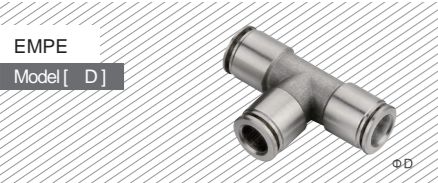

EMPE  
Model [ D ]

Tube(Metric):  
EMPE 4 EMPE 6 EMPE 8 EMPE 10 EMPE 12

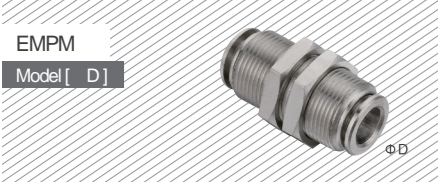

EMPM  
Model [ D ]

Tube(Metric):  
EMPM 04 EMPM 6 EMPM 08 EMPM 10 EMPM 12

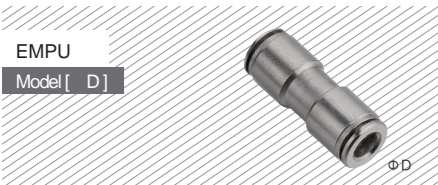

EMPU  
Model [ D ]

Tube(Metric):  
EMPU 4 EMPU 6 EMPU 8 EMPU 10 EMPU 12



EMPC-G  
Model [ D-T ]

Tube(Metric):  
EMPC 4-M5 EMPC 4-M6 EMPC 6-M5 EMPC 6-M6  
EMPC 4-G01 EMPC 4-G02 EMPC 6-G01 EMPC 6-G02  
EMPC 6-G03 EMPC 8-G01 EMPC 8-G02 EMPC 8-G03  
EMPC 10-G02 EMPC 10-G03 EMPC 10-G04 EMPC 12-G02  
EMPC 12-G03 EMPC 12-G04

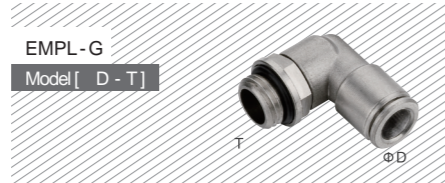

EMPL-G  
Model [ D-T ]

Tube(Metric)-Thread(PT):  
EMPL 4-M5 EML 4-M6 EML 4-G01 EML 4-G02  
EMPL 6-M5 EML 6-M6 EML 6-G01 EML 6-G02  
EMPL 6-G03 EML 8-G01 EML 8-G02 EML 8-G03  
EMPL 10-G02 EML 10-G03 EML 10-G04 EML 12-G02  
EMPL 12-G03 EML 12-G04

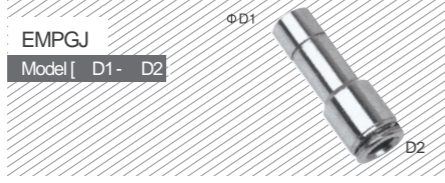

EMPGJ  
Model [ D1 - D2 ]

Tube(Metric):  
EMPGJ 6-4 EMPGJ 8-6 EMPGJ 10-6 EMPGJ 10-8  
EMPGJ 12-8 EMPGJ 12-10

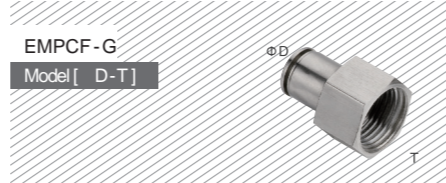

EMPCF-G  
Model [ D-T ]

Tube(Metric)-Thread(PT):  
EMPCF 4-G01 EMPCF 4-G02 EMPCF 6-G01 EMPCF 6-G02  
EMPCF 6-G03 EMPCF 8-G01 EMPCF 8-G02 EMPCF 8-G03  
EMPCF10-G02 EMPCF10-G03 EMPCF12-G02 EMPCF12-G03  
EMPCF 12-G04



EMPB-G  
Model [ D-T ]

Tube(Metric)-Thread(PT):  
EMPB 4-G01 EMPB 4-G02 EMPB 6-G01 EMPB 6-G02  
EMPB 6-G03 EMPB 8-G01 EMPB 8-G02 EMPB 8-G03  
EMPB 10-G02 EMPB 10-G03 EMPB 10-G04 EMPB 12-G02  
EMPB 12-G03 EMPB 12-G04

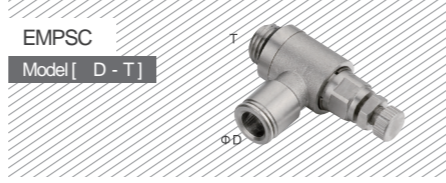

EMPSC  
Model [ D-T ]

Tube(Metric)-Thread(PT):  
EMPSC 4-M5 EMPSC 4-M6 EMPSC 6-M5 EMPSC 6-M6  
EMPSC 4-G01 EMPSC 4-G02 EMPSC 6-G01 EMPSC 6-G02  
EMPSC 6-G03 EMPSC 8-G01 EMPSC 8-G02 EMPSC 8-G03  
EMPSC 10-G02 EMPSC 10-G03 EMPSC 10-G04  
EMPSC 12-G02 EMPSC 12-G03 EMPSC 12-G04

## Italian Style Metal One Touch-In Fitting

### How to Order?

Order Example:  
EMC Series, Orifice 6mm, For Tube 8mm, 1/8" Thread, Model: EMC06-01

EMC	08	04
EMC Series	03:Orifice 3mm, For tube 4mm 04:Orifice 4mm, For tube 6mm 06:Orifice 6mm, For tube 8mm 08:Orifice 8mm, For tube 10mm 10:Orifice 10mm. For tube 12mm	Thread 01:1/8" 02:1/4" 03:3/8" 04:1/2"

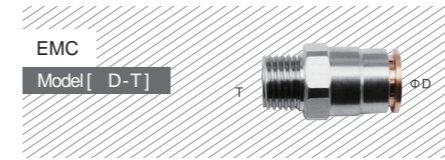

EMC  
Model [ D-T ]

Model:  
EMC4-M8 EMC4-01 EMC4-02 EMC4-03 EMC4-04  
EMC6-01 EMC6-02 EMC6-03 EMC6-04 EMC8-01  
EMC8-02 EMC8-03 EMC8-04 EMC10-01 EMC10-02  
EMC10-03 EMC10-04

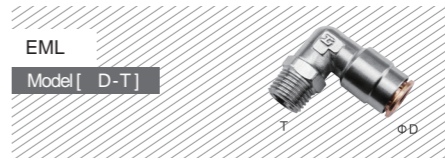

EML  
Model [ D-T ]

Model:  
EML3-M8 EML3-01 EML3-02 EML4-M8 EML4-01 EML4-02  
EML4-03 EML4-04 EML6-01 EML6-02 EML6-03 EML6-04  
EML8-01 EML8-02 EML8-03 EML8-04 EML10-01 EML10-02  
EML10-03 EML10-04



EMB  
Model [ D-T ]

Model:  
EMB3-M8 EMB3-01 EMB3-02 EMB4-M8 EMB4-01  
EMB4-02/EMB4-03 EMB4-04 EMB6-01 EMB6-02  
EMB6-03 EMB6-04 EMB8-01 EMB8-02 EMB8-03  
EMB8-04 EMB10-01 EMB10-02/EMB10-03 EMB10-04

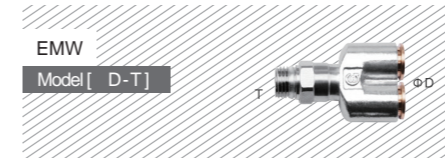

EMW  
Model [ D-T ]

Model:  
EMW4-M8 EMW4-01 EMW4-02 EMW4-03 EMW4-04  
EMW6-01 EMW6-02 EMW6-03 EMW6-04 EMW8-01  
EMW8-02 EMW8-03 EMW8-04 EMW10-01 EMW10-02  
EMW10-03 EMW10-04



EMSC  
Model [ D-T ]

Model:  
EMSC4-M8 EMSC4-01 EMSC4-02 EMSC4-03 EMSC4-04  
EMSC6-01 EMSC6-02 EMSC6-03 EMSC6-04 EMSC8-01  
EMSC8-02 EMSC8-03 EMSC8-04 EMSC10-01 EMSC10-02  
EMSC10-03 EMSC10-04

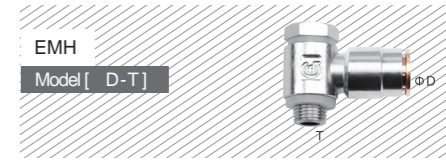

EMH  
Model [ D-T ]

Model:  
EMH3-M8 EMH3-01 EMH4-M8 EMH4-01 EMH6-01  
EMH6-02/EMH8-02 EMH8-03 EMH10-03 EMH10-04

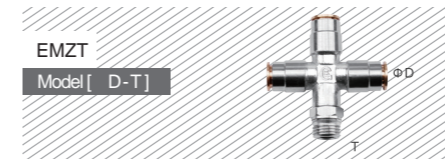

EMZT  
Model [ D-T ]

Model:  
EMZT3-M8 EMZT3-01 EMZT3-02 EMZT4-M8 EMZT4-01  
EMZT4-02 EMZT4-03 EMZT4-04 EMZT6-01 EMZT6-02  
EMZT6-03 EMZT6-04 EMZT8-01 EMZT8-02 EMZT8-03  
EMZT8-04 EMZT10-01 EMZT10-02 EMZT10-03 EMZT10-04



EMP  
Model [ D-T ]

Model:  
EMP3-M8 EMP3-01 EMP3-02 EMP4-M8 EMP4-01  
EMP4-02 EMP4-03 EMP4-04 EMP6-01/EMP6-02  
EMP6-03 EMP6-04 EMP8-01 EMP8-02 EMP8-03  
EMP8-04 EMP10-01 EMP10-02/EMP10-03 EMP10-04



EMF  
Model [ D-T ]

Model:  
EMF3-M8 EMF3-01 EMF3-02 EMF4-M8 EMF4-01  
EMF4-02/EMF4-03 EMF4-04 EMF6-01 EMF6-02  
EMF6-03 EMF6-04 EMF8-01 EMF8-02 EMF8-03  
EMF8-04 EMF10-01 EMF10-02/EMF10-03 EMF10-04

## Italian style metal one touch-in fitting

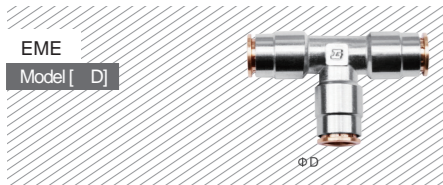

Model:  
EME3 EME4 EME6 EME8 EME10

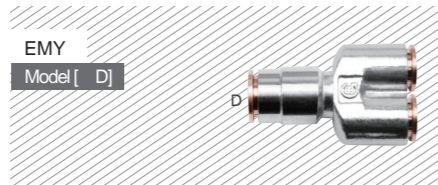

Model:  
EMY4 EMY6 EMY8 EMY10

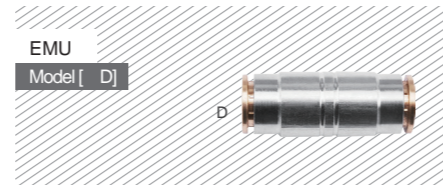

Model:  
EMU3 EMU4 EMU6 EMU8 EMU10

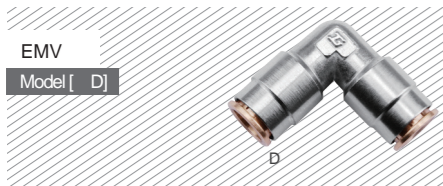

Model:  
EMV3 EMV4 EMV6 EMV8 EMV10

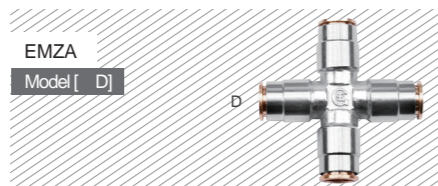

Model:  
EMZA3 EMZA4 EMZA6 EMZA8 EMZA10

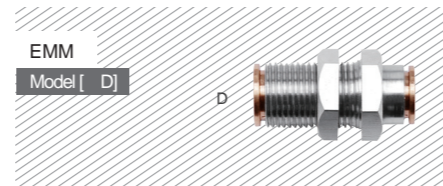

Model:  
EMM3 EMM4 EMM6 EMM8 EMM10

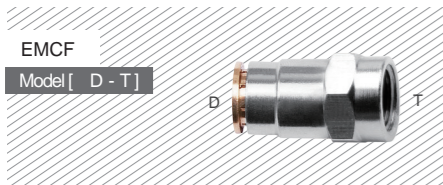

Model:  
EMCF3-M8 EMCF3-01 EMCF3-02 EMCF4-M8 EMCF4-01  
EMCF4-02 EMCF4-03 EMCF4-04 EMCF6-01 EMCF6-02  
EMCF6-03 EMCF6-04 EMCF8-01 EMCF8-02 EMCF8-03  
EMCF8-04 EMCF10-01 EMCF10-02 EMCF10-03 EMCF10-04

## SS One Touch-In Fitting

S1: SS316, S2: SS304

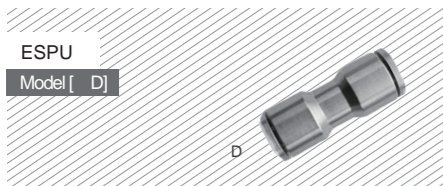

Tube(Metric):  
ESPU 4 ESPU 6 ESPU 8 ESPU 10 ESPU 12



Tube(Metric):  
ESPV 4 ESPV 6 ESPV 8 ESPV 10 ESPV 12

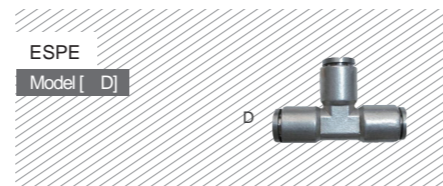

Tube(Metric):  
ESPE 4 ESPE 6 ESPE 8 ESPE 10 ESPE 12

## SS One Touch-In Fitting

S1: SS316, S2: SS304

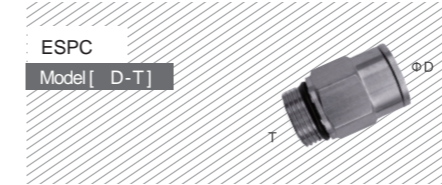

Tube(Metric) - Thread(PT):  
ESPC 4-G01 ESPC 4-G02 ESPC 6-G01 ESPC 6-G02  
ESPC 6-G03 ESPC 8-G01 ESPC 8-G02 ESPC 8-G03  
ESPC 8-G04 ESPC 10-G02 ESPC 10-G03 ESPC 10-G04  
ESPC 12-G02 ESPC 12-G03 ESPC 12-G04 ESPC 4-M5  
ESPC 4-M6  
ESPC 6-M5 ESPC 6-M6



Tube(Metric) - Thread(PT):  
ESPD 4-01 ESPD 4-02 ESPD 6-01 ESPD 6-02 ESPD 6-03  
ESPD 8-01 ESPD 8-02 ESPD 8-03 ESPD 10-02 ESPD 10-03  
ESPD 10-04 ESPD 12-02 ESPD 12-03 ESPD 12-04



Tube(Metric) - Thread(PT):  
ESM 4-01 ESM 4-02 ESM 6-01 ESM 6-02 ESM 8-02 ESM 8-03



Tube(Metric) - Thread(PT):  
ESPCF 4-G01 ESPCF 4-G02 ESPCF 6-G01 ESPCF 6-G02  
ESPCF 6-G03 ESPCF 8-G01 ESPCF 8-G02 ESPCF 8-G03  
ESPCF 10-G02 ESPCF 10-G03 ESPCF 12-G02 ESPCF 12-G03  
ESPCF 12-G04



Tube(Metric) - Thread(PT):  
ESPL 4-M5 ESPL 4-M6 ESPL 4-G01 ESPL 4-G02 ESPL 6-M5  
ESPL 6-M6 ESPL 6-G01 ESPL 6-G02 ESPL 6-G03  
ESPL 8-G01 ESPL 8-G02 ESPL 8-G03 ESPL 10-G02 ESPL 10-G03  
ESPL 10-G04 ESPL 12-G02 ESPL 12-G03 ESPL 12-G04



Tube(Metric) - Thread(PT):  
ESMC 4 01 ESMC 4 02 ESMC 6 01 ESMC 6 02 ESMC 8 01  
ESMC 8 02 ESMC 10 02 ESMC 10 03 ESMC 12 02 ESMC 12 03  
ESMC 12 04

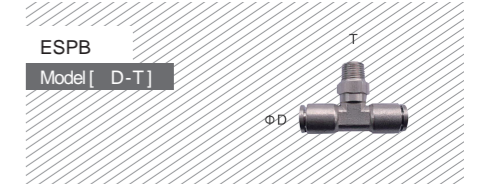

Tube(Metric) - Thread(PT):  
ESPB 4-01 ESPB 4-02 ESPB 6-01 ESPB 6-02 ESPB 6-03  
ESPB 8-01 ESPB 8-02 ESPB 8-03 ESPB 10-02 ESPB 10-03  
ESPB 10-04 ESPB 12-02 ESPB 12-03 ESPB 12-04

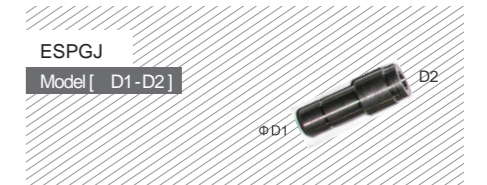

Tube(Metric):  
ESPGJ 4-6 ESPGJ 4-8 ESPGJ 6-8 ESPGJ 6-10 ESPGJ 8-10  
ESPGJ 8-12 ESPGJ 10-12



Tube(Metric):  
ESPM 4 ESPM 6 ESPM 8 ESPM 10 ESPM 12

Note: Standard with G thread, PT thread is available. Also inch size fitting available

USA Style Fitting Metal Fitting

HOW to Order?



Model:  
EC1/8-10-32UNF EC1/8-1/8N EC5/32-10-32UNF EC5/32-1/8N EC5/32-1/4N EC5/32-1/2N EC3/16-10-32UNF EC3/16-1/8N  
EC3/16-3/8N EC3/16-1/2N EC1/4-10-32UNF EC1/4N-1/8N EC1/4N-1/4N EC1/4-3/8N EC1/4-1/2N EC5/16-3/8N EC5/16-1/2N  
EC3/8-1/8N EC3/8-1/4N EC3/8-3/8N EC3/8-1/2N EC1/2-1/4N EC1/2-3/8N EC1/2-1/2N EC3-1/8 EC4-1/8 EC4-1/4 EC5-1/8  
EC6-1/8 EC6-1/4 EC6-3/8 EC6-1/2 EC8-1/8 EC8-1/4 EC8-3/8 EC8-1/2 EC10-1/8 EC10-1/4 EC10-3/8 EC10-1/2 EC12-1/4  
EC12-3/8 EC12-1/2



Model:  
EL1/8-1/8N EL1/8-1/4N EL5/32-1/8N EL5/32-1/4N EL5/32-3/8N EL5/32-1/2N EL3/16-1/8N EL3/16-1/4N EL3/16-3/8N  
EL3/8-1/2N EL3/16-1/2N EL1/4-1/8N EL1/4-1/4N EL1/4-3/8N EL1/4-1/2N EL5/16-1/8N EL5/16-1/4N EL5/16-3/8N EL3/8-1/8N  
EL1/8-1/4N EL3/8-1/4N EL3/8-3/8N EL3/8-1/2N EL3/8-M16 EL1/2-1/4 EL1/2-3/8N EL1/2-1/2N EL1/2-M16 EL4-1/8N  
EL5-1/8 EL6-1/8N EL6-1/4 EL6-3/8 EL6-1/2 EL8-1/8 EL8-1/4 EL8-3/8 EL8-1/2 EL10-1/8 EL10-1/4 EL10-3/8 EL10-1/2  
EL12-1/4 EL12-3/8 EL12-1/2



Model:  
ED1/8-1/8N ED1/8-1/4N ED5/32-1/8N ED5/32-1/4N ED5/32-3/8N ED5/32-1/2N ED3/16-1/8N ED3/16-1/4N ED3/16-3/8N  
ED3/16-1/2N ED1/4-1/8N ED1/4-1/4N ED1/4-3/8N ED1/4-1/2N ED5/16-1/8N ED5/16-1/4N ED5/16-3/8N ED5/16-1/2N  
ED3/8-1/8N ED3/8-1/4N ED3/8-3/8N ED3/8-1/2N ED1/2-1/4N ED1/2-3/8N ED1/2-1/2N ED6-1/8 ED6-1/4 ED6-3/8 ED6-1/2  
ED8-1/8 ED8-1/4 ED8-3/8 ED8-1/2 ED12-1/4 ED10-1/8 ED10-1/4 ED10-3/8 ED10-1/2 ED12-1/4N ED12-3/8 ED12-1/2

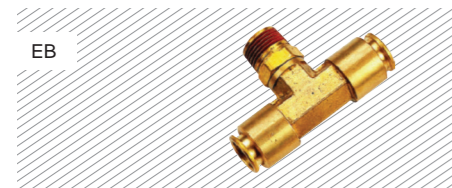

Model:  
EB1/8-1/8N EB1/8-1/4N EB5/32-1/8N EB5/32-1/4N EB5/32-3/8N EB5/32-1/2N EB3/16-1/8N EB3/16-1/4N  
EB3/16-3/8N EB3/16-1/2N EB1/4-1/8N EB1/4-1/4N EB1/4-3/8N EB1/4-1/2N EB5/16-1/8N EB5/16-1/4N  
EB5/16-3/8N EB5/16-1/2N EB3/8-1/8N EB3/8-1/4N EB3/8-3/8N EB3/8-1/2N EB1/2-1/4N EB1/2-3/8N EB1/2-1/2N  
EB6-1/8/EB6-1/4 EB6-3/8 EN6-1/2 EB8-1/8 EB8-1/4 EB8-3/8 EB8-1/2/EB10-1/8 EB10-1/4/EB10-3/8 EB10-1/2  
EB12-1/4 EB12-3/8 EB12-1/2



Model:  
EE-1/8 EE-5/32 EE-3/16 EE-1/4 EE-5/16 EE-3/8 EE-1/2  
EE-3 EE-4 EE-5 EE-6 EE-8 EE-10 EE-12

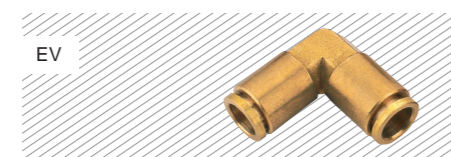

Model:  
EV1/8 EV8 EV5/32 EV10 EV3/16 EV12 EV1/4  
EV5/16 EV3/8 EV1/2 EV3 EV4 EV5 EV6



Model:  
EM-1/4 EM-3/8 EM-1/2  
Inch tube & metric tube are both available, and there are PT, NPT, BSP, NPTF thread for your reference.

USA Style Fitting / Metal Fitting



Model:  
ECF1/4-1/8N ECF1/4-1/4N ECF3/8-1/4N ECF3/8-3/8N  
ECF6-1/8 ECF6-1/4 ECF8-1/4 ECF10-1/4 ECF10-3/8



Model:  
EPLL1/8-1/8N EPLL5/32-1/8N EPLL5/32-1/4N EPLL1/4-1/8N  
EPLL1/4-1/4N EPLL1/4-3/8N EPLL3/8-1/8N EPLL3/8-1/4N  
EPLL3/8-3/8N EPLL3/8-1/2N EPLL1/2-3/8N EPLL3-1/4  
EPLL4-1/4 EPLL6-1/8 EPLL6-1/4 EPLL8-1/8 EPLL8-1/4  
EPLL10-1/8 EPLL10-1/4 EPLL10-3/8 EPLL12-3/8 EPLL12-1/2

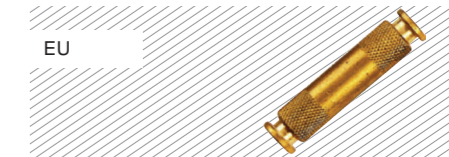

Model:  
EU1/8 EU5/32 EU3/16 EU1/4 EU5/16 EU3/8 EU1/2 EU3  
EU4 EU5 EU6 EU8 EU10 EU12

Metal Fitting



Model:  
EC-01 EC-02 EC-03 EC-04



Model:  
EF-01M EF-02M EF-03M EF-04M  
EF-05M



Model:  
EV01 EV02 EV03 EV04



Model:  
EL01 EL02 EL03 EL04



Model:  
EF-01F EF-02F EF-03F EF-04F



Tube(Metric):  
EH-01 EH-02 EH-03 EH-04



Model:  
EHU-01 EHU-02 EHU-03 EHU-04



Model:  
EHC-01 EHC-02 EHC-03 EHC-04

## Metal Fitting

### Natural Colour/Galvanization Pipe Thread Series



EFM 1/8-1/8 EFM 1/8-1/4 EFM 1/8-3/8  
EFM 1/4-3/8 EFM 1/4-1/4 EFM 1/4-3/8  
EFM 1/4-1/2 EFM 3/8-1/8 EFM 3/8-1/4  
EFM 3/8-3/8 EFM 3/8-1/2 EFM 1/2-4/1  
EFM 1/4-1/4 EFM 1/2-3/8 EFM 1/2-3/8  
EFM 1/2-1/2



ELN 1/8-1/8 ELN 1/8-1/4 ELN 1/4-1/4  
ELN 1/4-1/4 ELN 3/8-1/8 ELN 3/8-1/4  
ELN 3/8-3/8 ELN 1/2-1/4 ELN 1/2-3/8  
ELN 1/2-1/2 ELN 3/4-1/2 ELN 3/4-3/4

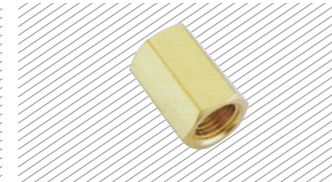

ECF 1/8-1/8 ECF 1/4-1/8 ECF 1/4-1/4 ECF  
3/8-1/4 ECF 3/8-1/8 ECF 3/8-1/4 ECF 1/2-  
3/8 ECF 1/2-1/4 ECF 1/2-3/8 ECF 3/4-1/2  
ECF 3/4-3/4



EBU 1/4-1/8 EBU 3/8-1/8 EBU 3/8-1/4  
EBU 1/2-1/8 EBU 1/2-1/4 EBU 1/2-3/8  
EBU 3/4-1/4 EBU 3/4-3/8 EBU 3/4-1/4  
EBU 1"-1/4 EBU 1"-3/8 EBU 1"-1/2  
EBU 1"-3/4



EIP1/8 EIP1/4 EIP3/8 EIP1/2 EIP3/4



EP1 1/8 EP1 1/4 EP1 3/8 EP1 1/2 EP1 3/4  
EP1 1"



ETF 1/8 ETF 1/4 ETF 3/8 ETF 1/2



ELF 1/8 ELF 1/4 ELF 3/8 ELF 1/2



EFM1 1/4-1/8 EFM1 1/8-1/4 EFM1 1/4-1/8  
EFM1-1/4-1/4 EFM1 1/4-3/8 EFM1 3/8-1/4  
EFM1 3/8-3/8 EFM1 1/2-1/2



ETM 1/8 ETM 1/4 ETM 3/8 ETM 1/2



ELFM 1/8-1/8 ELFM 3/8-1/2 ELFM 1/8-1/4  
ELFM 1/2-3/8 ELFM 1/4-1/8 ELFM 1/2-1/2  
ELFM 1/4-1/4 ELFM 1/4-3/8 ELFM 3/8-1/8  
ELFM 3/8-1/4 ELFM 3/8-3/8



ECN 1/8-1/8 ECN 1/4-1/8 ECN 1/4-1/4  
ECN 3/8-1/8 ECN 3/8-1/4 ECN 3/4-3/8  
ECN 1/2-1/8 ECN 1/2-1/4 ECN 1/2-3/8  
ECN 1/2-1/2 ECN 3/4-1/4 ECN 3/4-3/8  
ECN 3/4-1/2 ECN 3/4-3/4 ECN 1"-1/2  
ECN1"-3/4 ECN 1"-1" ECN 1"1/4-1"1/4

## Metal Fitting

### Natural Colour/Galvanization Insert Core Series



EHH 3/16 EHH 1/4 EHH 5/16 EHH 3/8 EHH 1/2 EHH 5/8  
EHH 3/4

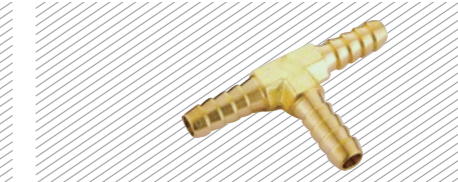

ETH 1/8 ETH 3/16 ETH 1/4 ETH 5/16 ETH 3/8 ETH 1/2 ETH  
5/8 ETH 3/4



ECH 1/8-1/8 ECH 1/8-3/16 ECH 1/8-1/4 ECH 1/8-5/16  
ECH 1/8-3/8 ECH 1/4-1/4 ECH 1/4-3/16 ECH 1/4-1/4  
ECH 3/8-1/4 ECH 3/8-5/16 ECH 3/8-3/8 ECH 3/8-1/2  
ECH 3/8-5/8 ECH 3/8-3/4 ECH 1/2-1/4 ECH 1/2-5/16  
ECH 1/2-3/8 ECH 1/2-1/2 ECH 1/2-5/8 ECH 1/2-3/4  
ECH 1/2-1 ECH 3/4-3/8 ECH 3/4-1/2 ECH 3/4-5/8  
ECH 3/4-3/4 ECH 3/4-1 ECH 1-1/2 ECH 1-3/4 ECH 1-1  
ECH 1-1 1/4 ECH1-1 1/2 ECH1 1/4-3/4 ECH 1 1/4-1  
ECH 1 1/4-1 1/4 ECH 1 1/4-1 1/2 ECH 1 1/2-1 ECH 1 1/2-1 1/4  
ECH 1 1/2-1 1/2



ELH 1/8-1/8 ELH 1/8-3/16 ELH 1/8-1/4 ELH 1/8-5/16  
ELH 1/8-3/8 ELH 1/4-1/4 ELH 1/4-5/16 ELH 1/4 3/8  
ELH 1/4-1/4 ELH 1/4-5/8 ELH 3/8-1/4 ELH 3/8-5/16  
ELH 3/8-3/8 ELH 3/8-1/2 ELH 3/8-5/8 ELH 1/2-1/4  
ELH 1/2-5/16 ELH 1/2 3/8 ELH 1/2-1/2 ELH 1/2-5/8  
ELH 1/2-3/4 ELH 3/4-1/2 ELH 3/4-5/8 ELH 3/4-3/4  
ELH 3/4-1 ELH 1-3/4 ELH 1-1 ELH 1-1 1/4



ELH1 1/4-1/4 ELH1 1/4-5/16 ELH1 1/4-3/8 ELH1 3/8-3/8  
ELH1 3/8-1/2

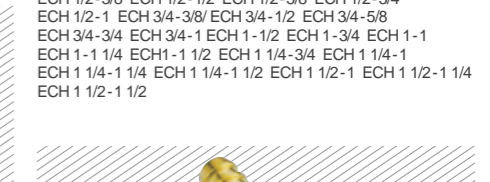

ECHF 1/8-1/4 ECHF 1/8-5/16 ECHF 1/8-3/8 ECHF 1/4-3/16  
ECHF 1/4-1/4 ECHF 1/4-5/16 ECHF 1/4-3/8 ECHF 1/4-1/2  
ECHF 3/8-1/4 ECHF 3/8-5/16 ECHF 3/8-3/8 ECHF 3/8-1/2  
ECHF 1/2-1/4 ECHF 1/2-5/16 ECHF 1/2-3/8 ECHF 1/2-1/2

### Natural Colour/Galvanization Copper Buckle Series



ELM 1/8-1/8 ELM 1/8-3/16 ELM 1/8-1/4 ELM 1/8-5/16  
ELM 1/8-3/8 ELM 1/4-1/8 ELM 1/4-3/16 ELM 1/4-1/4  
ELM 1/4-5/16 ELM 1/4-3/8 ELM 1/4-1/2 ELM 3/8-1/4  
ELM 3/8-5/16 ELM 3/8-3/8 ELM 3/8-1/2 ELM 3/8-5/8  
ELM 1/2-1/4 ELM 1/2-5/16 ELM 1/2-3/8 ELM 1/2-1/2  
ELM 1/2-5/8 ELM 1/2-3/4



ECM 1/8-1/8 ECM 1/8-3/16 ECM 1/8-1/4 ECM 1/8-5/16  
ECM 1/8-3/8 ECM 1/4-1/8 ECM 1/4-3/16 ECM 1/4-1/4  
ECM 1/4-5/16 ECM 1/4-3/8 ECM 3/8-5/16 ECM 3/8-1/2  
ECM 3/8-5/8 ECM 3/8-1/4 ECM 3/8-5/8 ECM 1/2-1/4  
ECM 1/2-5/16 ECM 1/2-3/8 ECM 1/2-1/2 ECM 1/2-5/8 ECM  
3/4-3/8 ECM 3/4-1/2 ECM 3/4-5/8 ECM 3/4-3/4

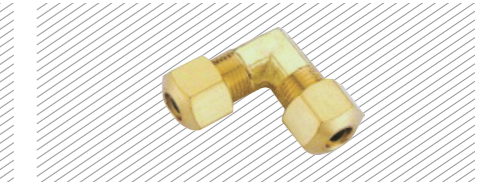

EULM 5 EULM 6 EULM 8 EULM 10 EULM 12 EULM 15  
EULM 1/8 EULM 3/16 EULM 1/4 EULM 5/16 EULM 3/8  
EULM 1/2 EULM 5/8 EULM3/4

### Metal Fitting

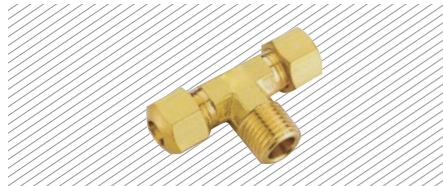

EBTM 1/8-1/4 EBTM 1/8-5/16 EBTM 1/8-3/8 EBTM 1/4-1/4  
EBTM 1/4-5/16 EBTM 1/4-3/8 EBTM 1/4-1/2 EBTM 3/8-1/4  
EBTM 3/8-5/16 EBTM 3/8-3/8 EBTM 3/8-1/2 EBTM 3/8-5/8  
EBTM 1/2-1/4 EBTM 1/2-5/16 EBTM 1/2-3/8 EBTM 1/2-1/2  
EBTM 1/2-5/8



ELMF 1/8-3/16 ELMF 1/8-1/4 ELMF 1/8-5/16 ELMF 1/8-3/8  
ELMF 1/4-1/4 ELMF 1/4-5/16 ELMF 1/4-3/8 ELMF 1/4-1/2  
ELMF 3/8-5/16 ELMF 3/8-3/8 ELMF 3/8-1/2

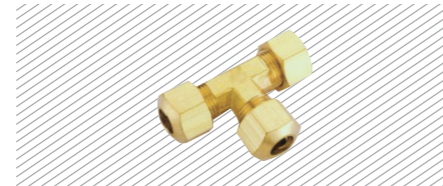

EUTM 5 EUTM 6 EUTM 8 EUTM 10 EUTM 12 EUTM 1/8  
EUTM 3/16 EUTM 1/4 EUTM 5/16 EUTM 3/8 EUTM 1/2  
EUTM 5/8



EUCM 10-6 EUCM 12-10 EUCM 3/8-3/8 EUCM 1/2-1/2  
EUCM 5/8-5/8

### Natural Colour/Galvanization Quick Twist Series



EUCB4 EUCB6 EUCB8 EUCB 10 EUCB 12 EUCB 1/4  
EUCB 5/16 EUCB 3/8 EUCB 1/2

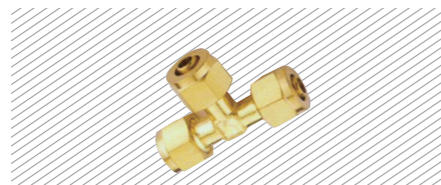

EUTB 4 EUTB 6 EUTB 8 EUTB 10 EUTB 12 EUTB 1/4  
EUTB 5/16 EUTB 3/8 EUTB 1/2

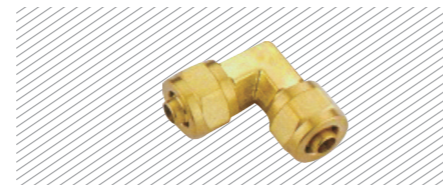

EULB 4 EULB 6 EULB 8 EULB 10 EULB 12 EULB 1/4 EULB  
5/16 EULB 3/8 EULB 1/2

### Natural Colour Galvanization Quick Twist Series



ELBF1/8-6 ELBF1/8-8 ELBF1/4-6  
ELBF1/4-8 ELBF1/4-10 ELBF1/4-12  
ELBF3/8-6 ELBF3/8-8 ELBF3/8-10  
ELBF3/8-12



ETB 1/8-4 ETB 1/8-6 ETB 1/8-8  
ETB 1/8-10 ETB 1/4-6 ETB 1/4-8  
ETB 1/4-10 ETB 1/4-12 ETB 3/8-6  
ETB 3/8-8 ETB 3/8-10 ETB 3/8-12



ECBF 1/8-4 ECBF 1/8-6 ECBF 1/8-8  
ECBF 1/8-10 ECBF 1/4-6 ECBF 1/4-8  
ECBF 1/4-10 ECBF 1/4-12 ECBF 3/8-6  
ECBF 3/8-8 ECBF 3/8-10 ECBF 3/8-12  
ECBF 1/2-6 ECBF 1/2-8 ECBF 1/2-10  
ECBF 1/2-12



ECB 1/4-28UNF-4 ECB 11/4-28UNF-6  
ECB 1/8-4 ECB 1/8-6 ECB 1/8-8  
ECB 1/8-10 ECB 1/4-6 ECB 1/4-8  
ECB 1/4-10 ECB 1/4-12 ECB 3/8-6  
ECB 3/8-8 ECB 3/8-10 ECB 3/8-12  
ECB 1/2-6 ECB 1/2-8 ECB 1/2-10  
ECB 1/2-12

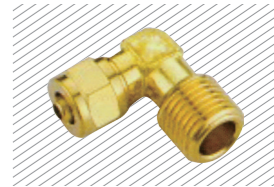

ELB 1/16-4 ELB 1/16-6 ELB 1/8-4  
ELB 1/8-6 ELB 1/8-8 ELB 1/8-10  
ELB 1/4-6 ELB 1/4-8 ELB 1/4-10  
ELB 1/4-12 ELB 3/8-6 ELB 3/8-8  
ELB 3/8-10 ELB 3/8-12 ELB 1/2-6  
ELB 1/2-8 ELB 1/2-10 ELB 1/2-12

### Natural Colour/Galvanization Flared Fitting Series



ECS 1/8-1/4 ECS 1/8-5/16 ECS 1/8-3/8  
ECS 1/4-1/4 ECS 1/4-5/16 ECS 1/4-3/8  
ECS 1/4-1/2 ECS 1/4-5/8 ECS 3/8-1/4  
ECS 3/8-5/16 ECS 3/8-1/2 ECS 3/8-5/8  
ECS 1/2-1/4 ECS 1/2-5/16 ECS 1/2-3/8  
ECS 1/2-1/2 ECS 1/2-5/8 ECS 3/4-3/8  
ECS 3/4-1/2 ECS 3/4-5/8 / ECS 3/4-3/4



ELS1/8-3/16 ELS1/8-1/4 ELS1/8-5/16  
ELS 1/8-3/8 ELS 1/4-1 ELS 1/4-1/4  
ELS 1/4-5/16 ELS 1/4-3/8 ELS 1/4-1/2  
ELS 1/4-5/8 ELS 3/8-1/4 ELS 3/8-5/16  
ELS 3/8-3/8 ELS 3/8-1/2 ELS 3/8-5/8  
ELS 1/2-1/4 ELS 1/2-5/16 ELS 1/2-3/8  
ELS 1/2-1/2 ELS 1/2-5/8 ELS 1/2-3/8  
ELS 3/4-1/2 ELS 3/4-5/8 ELS 3/4-3/4

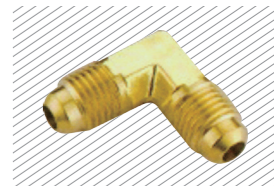

EULS 3/16 EULS 1/4 EULS 5/16  
EULS 3/8 EULS 1/2 EULS 1 1/4  
EULS 5/8 EULS 3/4

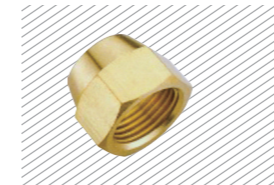

ESNT02 3/16 ESNT02 1/4 ESNT02 5/16  
ESNT02 3/8 ESNT02 1/2 ESNT02 5/8  
ESNT02 3/4



ETS 1/8-1/4 ETS 1/4-1/4 ETS 1/4-5/16  
ETS 1/4-3/8 ETS 1/4-1/2 ETS 3/8-1/4  
ETS 3/8-5/16 ETS 3/8-3/8 ETS 3/8-1/2  
ETS 1/2-1/4 ETS 1/2-5/16 ETS 1/2-3/8  
ETS 1/2-1/2 ETS 1/2-5/8

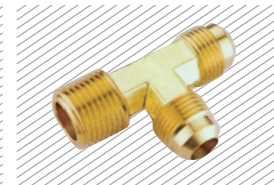

ESTS 1/8-1/4 ESTS 1/4-1/4 ESTS 1/4-5/16  
ESTS 1/4-3/8 ESTS 1/4-1/2 ESTS 3/8-1/4  
ESTS 3/8-5/16 ESTS 3/8-3/8 ESTS 3/8-1/2  
ESTS 1/2-1/4 ESTS 1/2-5/16 ESTS 1/2-3/8  
ESTS 1/2-1/2 ESTS 1/2-5/8



EUTS 1/8 EUTS 3/16 EUTS 1/4 EUTS 5/16  
EUTS 3/8 EUTS 1/2 EUTS 1 1/4 EUTS 5/8



EUCS 3/16 EUCS 1/4 EUCS 5/16 EUCS 3/8  
EUCS 1/2 EUCS 5/8 EUCS 3/4



### Milton Type Couplers and Plugs

MC 20F1:1/4" Female MC 30F1:3/8" Female Material:Brass/Steel	MC 20F1:1/4" Male MC 30F1:3/8" Male Material:Brass/Steel	MC 25H1:5/16" Hose MC 30H1:3/8" Hose Material: Brass/Steel	MC 20F2:1/4" Female MC 30F2:3/8" Female Material:Brass/Steel/Zinc	MC 20M2:1/4" Male MC 30M2:3/8" Male Material:Brass/Steel/Zinc	MC 25H2:5/16" Hose MC 30H2:3/6" Hose Material:Brass/Steel

MP 20F:1/4" Female MP 30F:3/8" Female Material:Brass/Steel	MP 20M:1/4" Male MP 30M:3/8" Male Material:Brass/Steel	MP 20H:1/4" Hose MP 30H:3/8" Hose Material:Brass/Steel

### Tru-Flate Couplers and Plugs

TC 20F1: 3/8" Female Material:Brass	TC 20H1:1/4" Hose Material:Brass	TC 25M1: 3/8" Male Material:Brass	TP 20F:1/4" Female TP 30F:3/8" Female Material:Brass	TP 20M:1/4" Male TP 30M:3/8" Male Material:Brass/Steel	TP 25H:5/16" Hose TP 30H:3/8" Hose Material:Brass/Steel

### Aro/ Orion/Type Couplers and Plugs/ Joint with 2 Milled Nuts

#### Aro Type Couplers and Plugs

AC 20F:1/4" Female AC 30F:3/8" Female Material:Brass/Steel	AC 20M:1/4" Male AC 30M:3/8" Male Material:Brass/Steel	AC 20P:1/4" Plug Material:Brass/Steel	AP 20H:1/4" Hose AP 30H:3/8" Hose Material:Brass/Steel	AP 20M:1/4" Male AP 30M:3/8" Male Material:Brass/Steel	AP 20F:1/4" Female AP 30F:3/8" Female Material:Brass/Steel

#### Orion Type Couplers and Plugs

OC20F1:1/4" Female OC30F1:3/8" Female	OC20M1:1/4" Male OC30M1:3/8" Male	OC20H1:1/4" Hose OC30H1:3/8" Hose	OC20F2:1/4" Male OC30F2:3/8" Male	OC20M2:1/4" Male OC30M2:3/0" Male	OP 20F1:1/4" Female OP 30F1:3/8" Female Material:Brass
OP 20M1:1/4" Male OP 30M1:3/8" Male Material:Brass	OP 20H1:5/16" Hose OP 30H1:3/8" Hose Material:Brass	OP 20F2:1/4" Female OP 30F2:3/8" Female Material:Brass	OP 20M2:1/4" Male OP 30M2:3/8" Male Material:Brass		

#### Joint with 2 Milled Nuts

IF-H-02:1/4 Material: Zinc	IM-H-02:1/4 Material:Zinc	IF-T-02:1/4 Material: Zinc	IM-T-02 IMT-03 IM-T-04 Material: Zinc

## Quick Couplers

Material: Steel zinc S.S.



Model:

SH-20 SH-30 SH-40  
SF-20 SF-30 SF-40  
SM-20 SM-30 SM-40  
SP-20 SP-30 SP-40

Size:

1/4" TUBE 3/8" TUBE 1/2" TUBE  
1/4PT 3/8PT 1/2PT  
1/4PT 3/8PT 1/2PT  
8\*5" TUBE 10\*6.5" TUBE 12\*8" TUBE

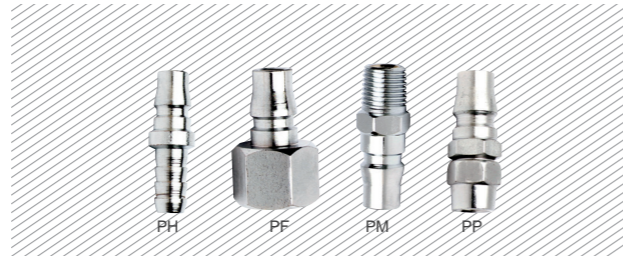

Model:

PH-20 PH-30 PH-40  
PF-20 PF-30 PF-40  
PM-20 PM-30 PM-40  
PP-20 PP-30 PP-40

Size:

1/4" TUBE 3/8" TUBE 1/2" TUBE  
1/4PT 3/8PT 1/2PT  
1/4PT 3/8PT 1/2PT  
8x5" TUBE 10x6.5" TUBE 12x8" TUBE



SMY:1/4PT 3/8PT



SML:1/4PT

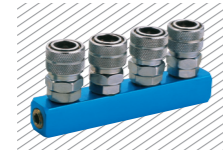

SMM:1/4PT



SMV:1/4PT 3/8PT

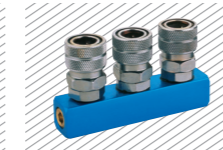

SMT:1/4PT

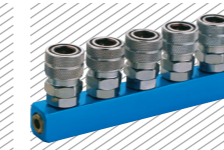

SMX:1/4PT

## Lincoln Type Quick Couplers

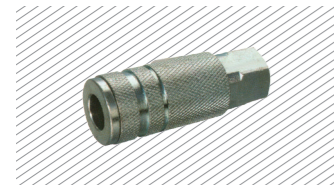

LC 20F2:1/4" Female LC 30F2:3/8" Female  
LC 40F2:1/2" Female Material:Brass/Steel

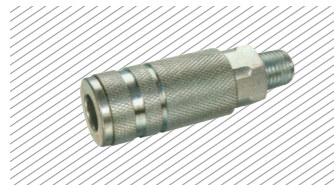

LC 20M2:1/4" Male LC 30M2:3/8" Male  
LC 40M2:1/2" Male Material:Brass/Steel

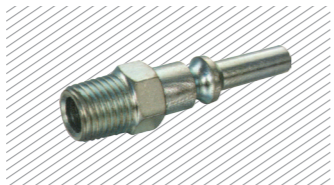

LC 20M3:1/4" Male LC 30M3:3/8" Male  
LC 40M3:1/2" Male Material:Brass/Steel

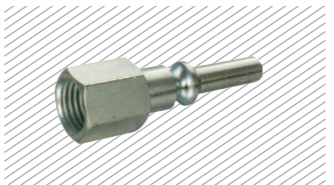

LC 20F3:1/4" Female LC 30F3:3/8" Female  
LC 40F3:1/2" Female Material:Brass/Steel

## Quick Couplers

### One Touch Type & Universal Quick Couplers

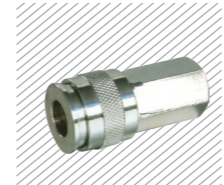

OUC 20F1:1/4" Female  
OUC 30F1:3/8" Female  
OUC 40F1:1/2" Female  
Material:Brass/Steel



OUC 20M1:1/4" Male  
OUC 30M1:3/8" Male  
OUC 40M1:1/2" Male  
Material:Brass/Steel

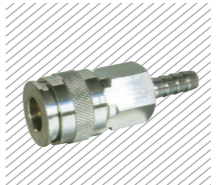

OUC 20-1:1/4" Hose  
OUC 30-1:3/8" Hose  
OUC 40-1:1/2" Hose  
Material:Brass/Steel



OUC 20F2:1/4" Female  
OUC 30F2:3/8" Female  
OUC 40F2:1/2" Female  
Material:Brass/Steel

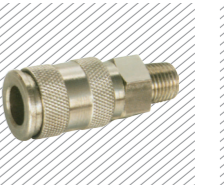

OUC 20M2:1/4" Male  
OUC 30M2:3/8" Male  
OUC 40M2:1/2" Male  
Material:Brass/Steel

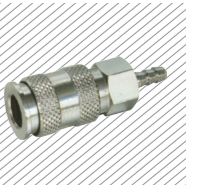

OUC 20-2:1/4" Hose  
OUC 30-2:3/8" Hose  
OUC 40-2:1/2" Hose  
Material:Brass/Steel

### England Self-locking Steel Type Couplers



ESL 20F1:1/4" Female ESL 30F1:3/8" Female  
ESL 40F1:1/2" Female Material:Brass/Steel

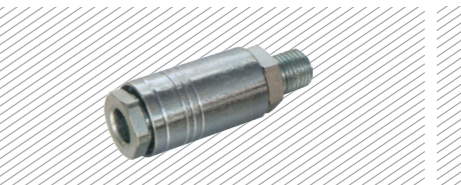

ESL 20M1:1/4" Male ESL 30M1:3/8" Male  
ESL 40M1:1/2" Male Material:Brass/Steel

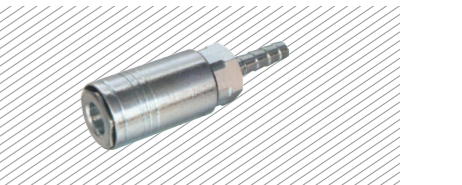

ESL 20-1:1/4" Hose ESL 30-1:3/8" Hose  
ESL 40-1:1/2" Hose Material:Brass/Steel

### England Type Female Couplers



EC 20F1:1/4" Female  
EC 30F1:3/8" Female  
EC 40F1:1/2" Female  
Material:Brass/Steel



EC 20M1:1/4" Male  
EC 30M1:3/8" Male  
EC 40M1:1/2" Male  
Material:Brass/Steel



EC 20-1:1/4" Hose  
EC 30-1:3/8" Hose  
EC 40-1:1/2" Hose  
Material:Brass/Steel



EC 20F2:1/4" Female  
EC 30F2:3/8" Female  
EC 40F2:1/2" Female  
Material:Brass/Steel



EC 20M2:1/4" Male  
EC 30M2:3/8" Male  
EC 40M2:1/2" Male  
Material:Brass/Steel



EC 20-2:1/4" Hose  
EC 30-2:3/8" Hose  
EC 40-2:1/2" Hose  
Material:Brass/Steel

## Quick Couplers Hydraulic Fitting

### 5PCS Quick Coupler Sets



5pc 1/4 " Industrial type coupler/plug kit



5pc 1/4 " Nitto type coupler/plug kit



5pc 1/4 " Aro type coupler/plug kit



5pc 3/8 " Automotive type coupler/plug kit



5pc 1/4 " Universal type coupler/plug kit



5pc 1/4 " Automotive type coupler/plug kit

### Swivel Connectors



Swivel Connector



1/4 " Female/Male Swivel Connector (Brass)



Tube (Metric): Swivel Connector

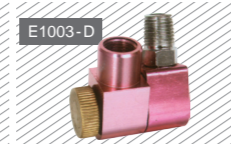

Surge-Swivel Connector  
360 ° Bi-Directional Swivel Action  
Reduces Hose Kinking



Swivel Connector



Swivel Quick Coupler

### Hydraulic Fitting Pressure: 0-600Bar



1/8"1/8 1/8"1/4 1/8"3/8 1/4"1/4 1/4"3/8 1/4"1/2 3/8"3/8 3/8"1/2 3/8"3/4 1/2"1/2 1/2"3/4 1/2"1 1/2"1-1/4 3/4"3/4 3/4"1 3/4"1 1/4 3/4"1-1/2 1"1 1"1-1/4 1"1-1/2 1"2 1-1/4"1-1/4 1-1/4"1-1/2 1-1/4"2 1-1/2"1-1/2 1-1/2"2 2"2



1/8\*6mm 1/8\*8mm 1/8\*10mm 1/4\*6mm 1/4\*8mm 1/4\*10mm 1/4\*12mm 3/8\*8mm 3/8\*10mm 3/8\*12mm 1/2\*6mm 1/2\*8mm 1/2\*10mm 1/2\*12mm 1/2\*14mm 1/2\*15mm 1/2\*16mm



D4 D5 D6 D8 D10 D12 D14 D16 D18 D20 D22 D25 D28 D32



D6 D8 D10 D12 D14 D16 D18 D20 D22 D25 D28 D32



D6 D8 D10 D12 D14 D16 D18 D20 D22 D25 D28 D32

## Air Gun



Air Duster (Short & Medium Nozzle)



Air Duster (Short & Medium Nozzle)



Air Duster (Long Nozzle)



Air Duster



Air Duster

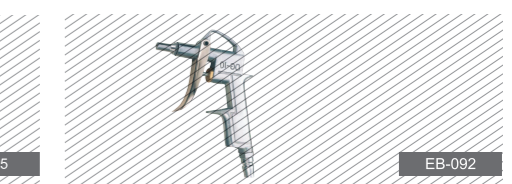

Air Duster (Short Nozzle)

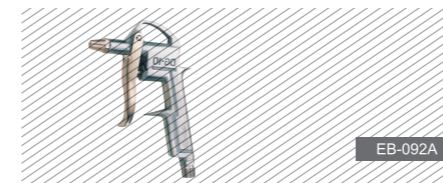

Air Duster (Short Nozzle)



Air Duster (Medium Nozzle)



Air Duster (Short & Medium Nozzle)



Air Blow Gun



Air Blow Gun



Air Blow Gun

## Air Gun



Air Duster (Medium Nozzle)



Air Duster (Medium Nozzle)



Air Duster (Medium Nozzle)



Air Duster (100mm Nozzle)



Air Duster (Long Nozzle)



Air Duster (Short Nozzle)



Air Duster (100mm Nozzle)



Air Duster (Short Nozzle)



Air Duster (Short Nozzle)



Pocket Blow Gun

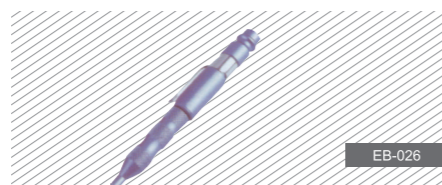

Pocket Blow Gun



Pocket Blow Gun

## Accessory

### PU TUBE

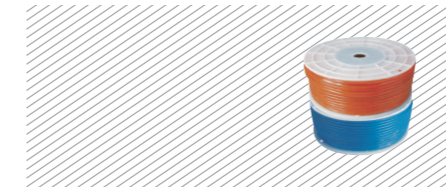

**Model:**  
4x2.5 6x4 8x5 8x6 10x6.5 12x8 14x10 16x12  
**Type:** Roll Type  
**Length:** 200m 100m

### PE TUBE

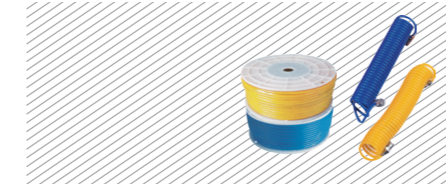

**Model:** 4x2.5 6x4 8x5 8x6 10x6.5 12x8  
**Type:** Roll Type/Spring Type  
**Length:** 200m 100m 50m 35m 30m

### PU TUBE



**Type:** Spring Type (With Fitting, Optional)  
**Length:** 15m 12m 9m 7.5m 6m

### NYLON TUBE

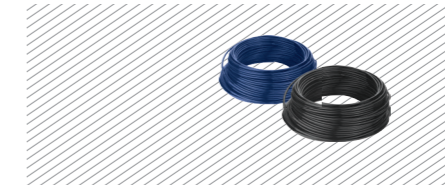

**Model:** 3x2 4x2.5 5x3 6x4 8x5 8x6 10x7.5 12x8 14x10 16x12  
**Type:** Roll Type  
**Length:** 200m 100m 50m 35m 30m

### PU Reinforced Tude

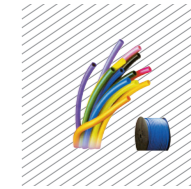

**Size:** 3/8x1/4 1/2x3/8 8x5  
10x6.5 11x6 12x8 13x9  
13.5x8 13.5x9.5 14x10  
14.5x10 15x9 16x10 16x11  
18x12 18x13  
**Operating Pressure:** 200Psi  
**Max. Pressure:** 600Psi  
**Temperature:** -20-65

### PU CUTTER

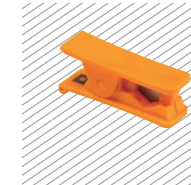

**Model:** ECP-01

### Air Gun Set



**Model:** DG-01S  
**Tube(Metric):**  
1pc air duster  
2pcs end fitting  
1medium nozzle  
1long nozzle



**Model:** DG-02S  
**Tube(Metric):**  
1pc air duster  
1pc medium nozzle



**Model:** DG-03S  
**Tube(Metric):**  
1 pc dual tire chuck, 1 pc pencil gauge, 4pcs 1/4" male plug,  
2pcs 1/4" female plug, 1 pc air blow gun, 1 pc 1/4" quick coupler  
2pcs double male connector, 1 pc double female connector,  
1 pc safety nozzle, 1 pc needle inflator, 1 pc tapered inflator,  
1 pc blow gun adaptor



**Model:** DG-04S  
**Tube(Metric):** 2 pcs quick coupler, 2 pcs female plug,  
2 pcs male plug, 1 pc double male connector,  
1 pc double female connector, 1 pc tapered seal tape,  
1 pc air blow gun, 1 pc tapered nozzle, 1 pc blow gun adaptor  
1 pc needle inflator, 1 pc dual-head tire chuck,  
1 pc air gauge, 1 pc 25FT memory recoil air hose

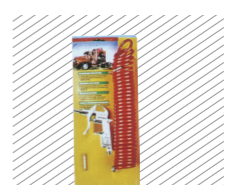

**Model:** DG-05S  
**Tube(Metric):**  
Ratef pressure: 70Psi  
Max pressure: 150Psi  
1 pc tire chuck, 1 pc air blow gun,  
1 pc 15FT memory recoil air hose

## Pressure Switch



HEP503 HEP110 HEP530D  
HEP506 HEP516 HEP530  
HEP506M HEP520 HEP530M

HEP830 HEP830HLM HEP830HM

HEC02

## Specifications

Model	Pressure Range(Bar)		Differential(Bar)		Factory Setting(Bar)		Max. Bellows Press(Bar)	
	Min.	Max.	Min.	Max.	Close	Open		
HEP503	-0.7	3	0.2	1.5	2 ± 0.01	1 ± 0.01	16.5	
HEP506	-0.7	6	0.4	4	3 ± 0.01	2 ± 0.01	16.5	
HEP506M	-0.7	8	Duplicate Voltage Disparity	1	3 ± 0.01	Manual Return	16.5	
HEP110	1	10	1	3	6 ± 0.01	5 ± 0.01	16.5	
HEP516	5	16	1	4	10 ± 0.01	8 ± 0.02	35	
HEP520	5	24	2	5	16 ± 0.02	13 ± 0.02	35	
HEP530D	5	30	5	10	20 ± 0.02	15 ± 0.02	35	
HEP530	8	30	Fixed 3-5		20 ± 0.02	15-17 ± 0.02	35	
HEP530M	8	30	Duplicate Voltage Disparity	4	20 ± 0.02	Manual Return	35	
HEP830	Low Side	-0.7	6	0.6	4	3 ± 0.01	2 ± 0.01	16.5
	High Side	8	30	Fixed 3-5		20 ± 0.02	17.5 ± 0.02	35
HEP830HM	Low Side	-0.7	6	0.6	4	3 ± 0.01	2 ± 0.01	16.5
	High Side	8	30	Duplicate Voltage Disparity	4	20	Manual Return	35
HEP830HLM	Low Side	-0.7	6	Duplicate Voltage Disparity	1	3	Manual Return	16.5
	High Side	8	30	Duplicate Voltage Disparity	4	20	Manual Return	35

## Pressure Gauge



**Description of goods:**  
Steel Shell, Plastic Lens, Bottom Connection(EY803)  
Steel Shell, Plastic Lens, Back Connection(EY804)  
**Model:**EY803, EY804  
**Optional:**  
1.5-6", F: With Flange, U: With U Clamp  
R: Rhombus Clamp

**How to order:** Pls tell us the model No. and don't forget to point out the pressure range.



**Description of goods:**  
Plastic Shell, Plastic Lens, Back Connection(EY805)  
Plastic Shell, Plastic Lens, Bottom Connection(EY806)  
**Model:**EY805, EY806  
**Optional:**  
1.5-4"

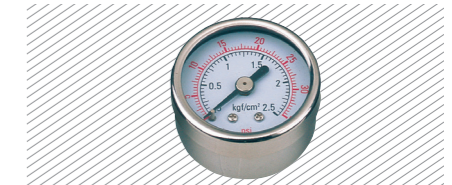

**Description of goods:**  
S.S 304 Shell, Back Connection, Without Oil (EY807)  
S.S 304 Shell, Bottom Connection, Without Oil (EY808)  
**Model:**EY807, EY808  
**Optional:**  
1.5-6", F: With Flange, U: With U Clamp  
R: Rhombus Clamp

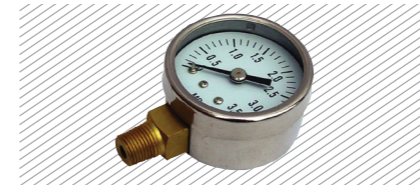

**Description of goods:**  
Full S.S, Bottom Connection, Without Oil (EY809)  
Full S.S, Back Connection, Without Oil (EY810)  
**Model:**EY809, EY810  
**Optional:**  
1.5-6", F: With Flange, U: With U Clamp  
R: Rhombus Clamp



**Description of goods:**  
S.S 304 Shell, Bottom Connection, With Oil  
**Model:**EYN801  
**Optional:**  
1.5-6"  
F: With Flange, U: With U Clamp, R: Rhombus Clamp



**Description of goods:**  
S.S 304 Shell, Back Connection, With Oil  
**Model:**EYN802  
**Optional:**  
1.5-6", F: With Flange, U: With U Clamp  
R: Rhombus Clamp



**Description of goods:**  
Full S.S, Bottom Connection, With Oil  
**Model:**EYN803  
**Optional:**  
1.5-6", F: With Flange, U: With U Clamp  
R: Rhombus Clamp



**Description of goods:**  
Full S.S, Back Connection, With Oil  
**Model:**EYN804  
**Optional:**  
1.5-6", F: With Flange, U: With U Clamp  
R: Rhombus Clamp

More special pressure gauges are available upon request, feel free to contact us for your personalized products!